

ISBN 978-83-66216-55-6

Abdugaliyeva G.B., Zhetesov S.S.,
Buzauova T.M., Mateshov A.K.

WAYS OF DEVELOPMENT AND IMPROVEMENT OF POWERED SUPPORTS

MONOGRAPHY

 **iScience**
Warsaw, Poland - 2021

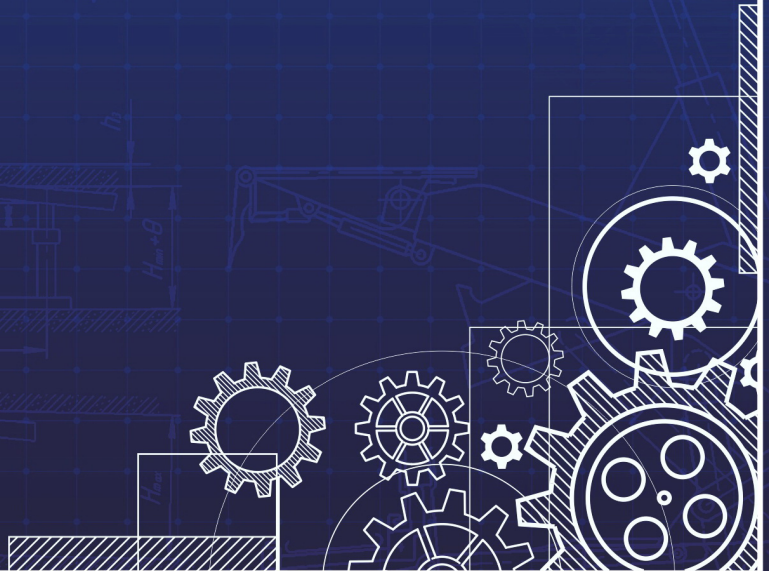

KARAGANDA TECHNICAL UNIVERSITY

**Abdugaliyeva G.B., Zhetesov S.S.,
Buzauova T.M., Mateshov A.K.**

**WAYS OF DEVELOPMENT
AND IMPROVEMENT
OF POWERED SUPPORTS**

**The monograph was approved by the Scientific
and Technical Council of the University**

Monography

Warsaw-2022

UDC 531.5
LBC 33.13
A14

**Recommended by the Scientific and Technical Council
of the University**

Reviewers:

K.M. Beisembaev - Department of Technological Equipment, Mechanical Engineering and Standardization, Karaganda Technical University, Doctor of Technical Sciences, Professor,

B.O. Zhakipbayev - Deputy Head of the shop of «TD Kargormash-M» LLP

S.K. Tutanov - Doctor of Technical Sciences, Professor of the Department of Higher Mathematics

Abdugaliyeva G.B.

A 14 Ways of development and improvement of powered supports: Monograph /G.B., Abdugaliyeva, S.S. Zhetesov, T.M. Buzauova, A.K. Mateshov: Karaganda Technical University, iScience Sp. z o. o. – Warsaw, 2022 – 157 p.

The monograph describes the method of designing mechanized supports, mechanized supports, and complexes, the basics of calculation, calculation of the strength of the elements of mechanized supports, as well as hydraulic systems of mechanized supports.

The monograph is intended for undergraduate students 6B07104 "Mechanical Engineering", 6B07111 "Technological machines and equipment (by industry)", undergraduates 7M07103 "Mechanical Engineering, 7M07109 "Technological machines and equipment (by industry)" and doctoral students 8D07104 "Mechanical Engineering", as well as for scientific and engineering workers involved in the design and construction of mechanized supports, aggregates, and support units.

UDC 531.5
LBC 33.13

ISBN 978-83-66216-55-6

© Karaganda Technical University, 2021.

© iScience Sp. z o. o.

CONTENT

Preface	4
1. Classification and design principles of powered supports	
1.1. Basic concepts and terminology	6
1.2. Classification of powered supports of the cleaning face.....	13
1.3. General principles of the design of powered supports.....	18
1.4. Design methodology of powered supports	27
1.5. Design of mechanical supports on the basis of unification.....	30
1.6. Construction of units and parts of the section powered supports	31
1.7. General principles of section layout of the powered supports.....	32
1.8. Basic mining and geological requirements for powered supports	34
1.9 Basic layout dimensions of treatment complexes with powered supports.....	39
2. Mechanical supports and complexes	
2.1. General information.....	43
2.2. Powered supports and complexes for thin layers with an angle up to 35°	45
2.3. Powered supports and complexes for shallow layers of medium capacity	54
2.4. Powered supports and complexes for powerful layers	66
3. Basics of calculating powered power supports	
3.1. Determination Of Loads On The Elements Of Powered Supports	75
3.2. Calculation for strength of elements powered supports.....	86
3.3. Calculation for the resistance of supports.....	98
3.4. Features of calculation of powered supports for powerful formations	101
3.5. Overlapping calculation fenced (shield) of power supports.....	105
3.6. Calculation of construction elements mechanized walking supports supporting type	109
3.7. Establishing critical load on the visor of the securing and supporting craft	122
4. Hydraulic systems of powered supports	
4.1. General information.....	130
4.2. Classification of sectional hydraulic diagrams	131
4.3. Principles of constructing a sectional fluid diagram powered supports	133
4.4 Optimization of the hydraulic circuit structure powered supports.....	138
4.5. Hydraulic circuits of powered supports.....	146
Conclusion.....	151
List of literature	156

Preface

At present, about 1300 complex mechanized working faces equipped with mobile hydraulic supports are operating in the mines of the CIS. The main basic machine of the complex is powered roof support.

Mechanized complexes with hydrofected supports have been created for all power ranges of coal seams (with the exception of layers with a capacity of less than 0.7 and more than 5.0 m and with angles of incidence of more than 35°).

Along with the improvement of existing structures, a new direction of creating powered supports with excavation functions has been developed. Such complexes allow additional removal of coal in the upper or lower part of the formation. This makes it possible to increase the range of removed reservoir capacities of 6-6.5m.

To increase the productivity of complex mechanized faces, it is necessary to improve the power and kinematic characteristics of powered supports, first of all, switch to a pressure of 32-40 MPa in the mainline and 50-80 Mpa in the hydraulic system of the rack, move sections with preliminary roof support or with the use of non-unloading walking powered supports of the crank mechanism type. This will improve the strength characteristics of the supports, increase the speed of fastening and increase the technical and economic indicators of the complexes, as well as expand the scope of application of supports on layers with difficult-to-control and unstable supports.

Specialists of mining engineering and miners are faced with major tasks to improve existing and create new systems of powered roof supports. In our opinion, they are as follows:

- improve methods for calculating supports in order to reduce their weight, material consumption, as well as the use of new functional elements, unified units and their hydraulic systems;
- to investigate the possibility of controlling kinematic circuits for rapid readjustment of complexes when changing the technological scheme or coal mining processes;
- to develop additional devices in the structures of the supports to ensure their correction, fast and high-quality transition of places of geological violations, as well as installation and dismantling;
- to increase the speed of longwall attachment, along with the development of new pumping systems with high pressure and flow, to investigate the possibility of using multi-head lines in longwalls, which allow parallel or group movement of sections;

- in the future, switch to such technological schemes that ensure maximum efficiency and reliability and minimal wear of the main equipment of the treatment face.

Leading specialists of research and development organizations and educational institutes are working on solving the problem of complex mechanization and automation of technological processes using coal mining complexes with powered roof supports.

The book offered to the readers is prepared mainly on the basis of research and development of various schemes of powered supports and their hydraulic drive, as well as new coal mining processes in MGI, KTU, Giprouglesh, taking into account promising work in this area.

The authors hope that this work will contribute to a more effective solution of the issues of mechanization of technological processes of coal mining in the treatment faces of coal mines.

1 CLASSIFICATION AND DESIGN PRINCIPLES OF POWERED SUPPORTS

1.1. Basic concepts and terminology

The support is an artificial structure erected to maintain the production in a safe and working condition and control the mountain pressure.

Mechanized cleaning face support is a self-moving sectional support designed to maintain roof rocks or fencing from them in order to preserve the bottom-hole space along the length of the cleaning face in working and safe condition, providing mechanization of the processes of fixing and controlling the roof, movement and retention of the bottom-hole conveyor or base beam together with the dredging machine.

The powered support (longwall set) is a system of sections-of the same type or of different types, arranged with a certain step and sequence along the length of the cleaning face and moving in the direction of the movement of the cleaning face.

The powered support section is an independent structural unit of the powered support of the cleaning face, capable of maintaining (fencing) the bottom-hole space of the cleaning face in working and safe condition on its limited length equal to the width of the section.

The section of the powered support (Fig. 1.1) consists of an overlap, a base and hydraulic racks, with the help of which the overlap resists the lowering and collapse of the roof rocks into the working space. The section is usually moved with the help of hydraulic jacks (one or two), however, the presence of a hydraulic movement jack is not mandatory for its structure. The section may additionally include the following devices: power connection of the base with the upper overlap, retention of the face chest, directional movement and stability of the section, retention of the downhole conveyor, active backup during movement, overlap of side gaps, rear fencing, etc.

Downhole support section is a support section that performs the functions of only maintaining the roof in the bottom-hole space.

The landing section of the support is a support section that performs the functions of not only maintaining the roof rocks in the working bottom-hole space, but also controlling the rock pressure (by means of collapse or smooth lowering of rocks).

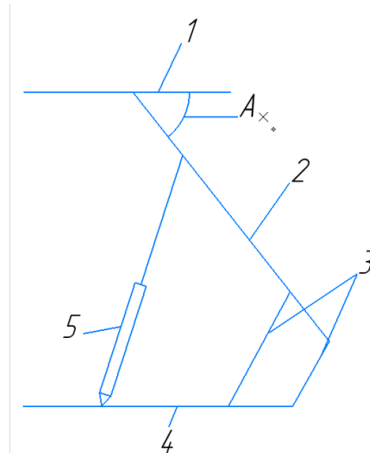

Figure 1.1. Section of the powered support:
 1-the supporting part of the overlap; 2-the protective part of the overlap;
 3-levers of the power connection of the base with the overlap; 4-the base;
 5-hydraulic rack; A-zone of possible jamming by rock

Linear section (set or group) - the same type or different types of support sections, repeated along the length of the cleaning face.

The end section is a support section that has a specific design due to its installation at the ends of the bench support set.

The scheme of movement of the powered support is a conditional schematic representation of the sequence of movement of sections or sets of support in the treatment mine.

Sequential movement of sections is the order of movement of sections of powered support, in which sections move sequentially one after another.

Chess movement of sections is the order of movement of sections of powered support, in which the even (or odd) sections move sequentially first, and then the odd (or even) sections sequentially.

Group movement sections, the order of movement of the powered roof support sections, which simultaneously moves a predetermined number of sections-group sections, the order of movement groups may be different (sequential, checkerboard, etc.).

The upper ceiling of the support is an element of the support section located at the roof and directly in contact with the roof rocks, relying on hydraulic supports (sometimes, in addition, on the base of the support or the soil) and protecting the working space of the cleaning face from the collapse of the roof rocks.

Rigid upper overlap is the upper overlap of the support section, which is a rectilinear or curved rigid beam.

Hinged upper overlap is the upper overlap of a support section consisting of two or more rigid beams pivotally connected to each other.

Elastic upper overlap - the upper overlap of the support section, which is an elastic beam.

Rigid elastic upper overlap is the upper overlap of the support section, combining rigid and elastic beams. Usually the elastic beam is the front cantilever part of the rigid upper floor.

A retractable roof is an element of the upper floor, which, moving out of the ceiling, the resulting cantilever element can support the roof rocks in the bottomhole space.

A preload upper layer is a cantilever movable part of the upper ceiling, which can be pressed against the roof rocks by one device or another (hydraulic jack, spring, etc.), regardless of the pressing force of the entire upper ceiling.

The base of the support section is the support element of the support section, which is in contact with the soil rocks and transmits the forces of the hydraulic struts to the soil.

The rack is the main supporting element of the support, which resists the lowering of the roof rock in the fixed workings.

The extensibility of the rack is the maximum permissible increase in the length of the rack due to the retractable part and its elements (for example, unscrewing the screw).

The coefficient of extensibility is the ratio of the height of the rack in the extended position to the height of the rack in the shifted position.

The hydrostoy shock absorber is an elastic element that allows the hydrostoy to deviate under the influence of the displacement of the roof rocks at a given angle from the initial position and automatically returns the hydrostoy to the initial position when unloading.

Pliability of the rack - reducing the length of the rack under load.

Initial spacer - the initial force created in the rack when it is installed in the working position.

The rasp coefficient is the ratio of the initial rasp force to the value of the nominal working resistance of the rack.

The initial resistance is the resistance of the rack to the lowering of the roof rocks at the moment of the beginning of subsidence of the sliding part relative to the rack body.

The working characteristic of the rack is the nature of the change in the resistance of the rack to the lowering of the roof rocks when it is malleable.

Unloading of the rack - reducing to zero the resistance of the rack to the roof rocks with simultaneous lowering of the retractable part until the rack is released from mountain pressure.

Remote unloading of the rack - the possibility of unloading the rack for safety purposes at a certain distance from the place of its installation (usually from 1 to 2 m).

The height of the rack: maximum - in the extremely extended position (maximum compliance); minimum - in the extremely shifted position (compliance is zero).

Hydraulic rack with the upper position of the working cylinder is a hydraulic rack in which the working cylinder is located above the handle of the pump drive and unloading device. According to such a design scheme, hydraulic proofing is usually performed for formations with a capacity of more than 2-2.5 m.

Hydraulic rack with the lower position of the working cylinder is a hydraulic rack in which the working cylinder is located below the handle of the drive of the pump and the unloading device. According to such a design scheme, hydraulic proofing is usually performed for formations with a capacity of up to 2-2.5 m.

Hydraulic sliding is the maximum possible change in the length of the rack with the help of a hydraulic drive.

Screw extensibility - the maximum possible change in the length of the rack due to the screw pair.

Hydro-screw extensibility is the maximum possible total change in the length of the rack with the help of a hydraulic drive and a screw pair.

Single hydraulic sliding is the maximum possible amount of change in the length of the rack due to the movement of the piston in the cylinder.

Double hydraulic sliding is the maximum possible value of changing the length of the rack due to two telescopically sliding hydraulic cylinders. With double hydraulic sliding, racks of powered supports and sometimes landing racks are performed, which is especially necessary in conditions of thin layers and layers with unstressed power.

The rack attachment is an easily removable element used to change the length of the hydraulic rack by a certain amount.

The active length of the nozzle is the size by which the length of the hydraulic rack increases stepwise when installing the nozzle.

Elastic compliance is a reduction in the length of the hydraulic strut due to elastic compression of the liquid and deformation of the cylinder walls and the sliding part.

Working elastic compliance is a decrease in the length of the hydraulic resistance from the moment it is installed in the working position

until the safety valve starts to operate (from the initial expansion to the nominal operating resistance).

The nominal operating resistance of the hydraulic rack is the average operating resistance of the rack when the safety valve is triggered.

The rate of lowering of the hydraulic support is the rate of lowering of the retractable part of the hydraulic support after it's unloading and loss of contact with the roof.

The speed of sliding of the hydraulic support is the speed of increasing the length of the rack when installed in the working position before the beginning of contact of the upper part or the rack with the roof.

The speed of the hydraulic strut is the rate of increase in the length of the hydraulic strut from the moment of contact of the upper part or the rack with the roof to the creation of the initial strut.

The operating pressure of the hydraulic resistance is the nominal average pressure of the safety valve when the hydraulic resistance reaches the nominal operating resistance.

The initial expansion pressure is the maximum pressure developed in the hydraulic cylinder when creating a given initial expansion.

The pressure of opening the safety valve is the pressure in the working cavity of the hydraulic seal at the time of opening the safety valve.

Closing pressure of the safety valve is the pressure in the working cavity of the hydraulic seal at the time of closing of the safety valve.

Working fluid is a fluid used to transfer energy in a hydraulic drive system.

Water-oil emulsion is a working fluid, which is a mixture of water with special additives (anti-pressure, anti-corrosion, etc.) and oils.

There are two types of water-oil emulsions: "water in oil" and "oil in water". In the first case, the water content in the oil reaches 60%, in the second - 98-92% (more often 97-95%). Abroad, the most common emulsions are of the "water in oil" type, in domestic practice - an emulsion of the "oil in water" type

A safety valve is a device that limits the pressure developed in the hydraulic drive system to a predetermined value in the working cavity of the hydraulic resistance, and, accordingly, the value of the working resistance of the hydraulic resistance. The safety valve is the most important element of the hydraulic drive. It usually consists of the following main elements: housing, seat, valve and elastic element (spring, compressed air or some other elastic element).

The elastic element of the valve is a pre-compressed elastic device that presses the valve to the seat. Cylindrical and disc springs, compressed gas, rubber, etc. can be used as an elastic element.

The life of the safety valve is the service life of the valve until the loss of tightness or a decrease in the opening pressure by an amount greater than 25% of the nominal operating pressure. The life of the hydraulic safety valve is determined in liters of liquid that has passed under pressure through the valve when the rack is malleable. It should be borne in mind that the life of the safety valve, all other things being equal, depends on the elasticity of the hydraulic system - side rocks (or hydraulic - press when tested in laboratory conditions), the volume of the working fluid locked by the valve in the hydraulic fluid and the flow rate of the working fluid passed through the valve per unit of time. For comparability of valve life test data, these factors must be taken into account.

Unloading device - a device for removing the load on the rack and removing it from the working position. It usually consists of a check valve and a mechanical or hydraulic actuator to open it.

The discharge valve is a mechanically or hydraulically controlled device that opens or closes the outlet of the working fluid from the working cavity of the hydrostoy.

A check valve is an automatically operating device that passes liquid in one direction and excludes the possibility of its passage in the opposite direction.

The hydraulic jack of movement is a power hydraulic cylinder, with which the support section moves, and in most cases, the bottom-hole conveyor.

Movement step - the amount of movement of the support section in one step in the direction of moving the cleaning face line.

The movement pressure of the support section, the conveyor flight is the maximum pressure of the working fluid created in the working cavity of the hydraulic jack for the development of the ultimate movement force.

The speed of movement of the section (set) of the support or conveyor flight is the speed of movement in the direction of moving the bottom line of the section (set) of the support or conveyor flight, due to the speed of movement of the rod of the hydraulic jack or hydraulic cylinder based on the area of the working cavity of the hydraulic jack, the performance of the pumping station, the resulting leaks, gear ratios and the accepted scheme of movement of sections of sets of support and conveyor flight, taking into account the number of hydraulic jacks working simultaneously for movement.

The performance of the support is the area of the working space (m^2) or the length of the cleaning face (m), which is re-fixed by the support per unit of time during its movement (the dimension of the performance of the

support during combine dredging is m/min, during plow dredging and dredging by coal mining units is m²/min).

The estimated performance of the support is the fixing of the working space area (m²/min) or the length of the cleaning face (m/min), determined only based on the estimated machine time and the accepted scheme of movement of the support sections, taking into account the time spent on unloading and initial strut of the hydraulic struts, and the movement of the operator to the adjacent section.

The technical performance of the support is the average speed of fixing the area of the working space (m²/min) or the length of the cleaning face (m/min), set taking into account the time spent on moving the support sections, unloading the racks and their initial strut, possible leaks and time spent on performing auxiliary operations (soil stripping, inevitable pauses in the management of the support sections, alignment of the sections, etc.).

Operational performance of the support - the average speed of fixing the area of the working space (m²/min) or the length of the cleaning face (m/min), defined as technical productivity, taking into account the additional time spent on troubleshooting due to malfunctions of the support, its hydraulic drive and electrical equipment and unreliable operation of the support itself (for example, the average time spent on leveling sections of the support, eliminating the consequences caused by the spillage of roof rocks into the workspace, the average time spent due to insufficient effort to move sections or the downhole conveyor, with additional pick-up of the upper rocks and time spent at the ends of the face, etc.).

The nominal working resistance of the support (tf/m², MPa) is the ratio of the sum of the nominal resistances of the hydraulic racks of the support to the area of the working space of the treatment face fixed by it.

The actual working resistance of the support (tf/m², MPa) is the ratio of the sum of the actual resistances of the hydraulic supports of the cleaning face at a given time, determined taking into account the magnitude of the lowering of the roof rocks, the speed of movement of the cleaning face, its length, the adopted scheme of movement of the sections of the support, the values of the initial strut of the hydraulic supports and their elastic compliance to the area of the working space of the cleaning face fixed with the support.

The roof tightening coefficient is the ratio of the projection of the area of all upper floors on the plane along the rock - coal contact to the area of the workspace fixed with a support.

The hydraulic lock is a controlled check valve, while the valve is opened by hydraulic or mechanical devices. It is used in powered supports as a discharge valve of hydraulic racks.

The hydroblock of the rack is the control equipment for the hydraulic support, usually consisting of a safety valve and a hydraulic lock mounted in a common housing. Sometimes the rack hydraulic unit and the rack hydraulic distributor are structurally assembled in one common block housing.

Electrohydrovalve is a valve distributor controlled remotely with the help of electric energy, having two fixed positions: open and closed, Used in automatic and remote control systems of powered supports.

Hydraulic line is a device for supplying working fluid.

Pressure hydraulic line is a hydraulic line that supplies liquid under pressure from the pump to energy consumers.

Drain hydraulic line is a hydraulic line that diverts the working fluid from energy consumers, as well as leaks into the reservoir for the working fluid.

Hydraulic support pumping station is an aggregate that provides power to the hydraulic drive system of mechanized or individual hydrofected support with a working fluid with a given capacity and pressure. It usually consists of a reservoir for working fluid, a make-up pump (it is also used to pump working fluid into the reservoir when it is replenished), two main pumps, two automatic unloading machines, coarse and fine filters, hydropneumoaccumulators and auxiliary devices (pressure switches, working fluid level indicator, switching taps, etc.).

Automatic unloading is a device that automatically switches the working pump from the pressure line when the set pressure is reached in it to the drain line and connects the pump to the pressure line when the pressure in it decreases to the set value.

During the period of disconnection from the pressure line, the discharge machine connects the pump to the drain line, circulating the working fluid from the tank through the pump into the tank at minimum pressure, unloading the pump from operation at full pressure on the safety valve.

Automatic unloading machines can be direct-acting and with servo control. The use of the latter in the hydraulic drive system of powered supports is preferable due to their greater reliability in operation.

1.2. Classification of powered supports of the cleaning face

The creation and implementation of powered supports made it possible to complete the complex mechanization of the treatment faces, additionally mechanizing the processes of fixing and controlling the roof and movement of the downhole conveyor (or base).

Powered supports are widespread in the world. In such important coal basins of the CIS as Pechora, Moscow region, Karaganda and Kuznetsky, work on the mechanization of the processes of fixing and controlling the roof of the treatment faces in conditions of shallow (up to 35 °) layers is almost completed. In general, the level of mechanization of fastening and roof management of treatment faces in the mines of the coal industry of the CIS has reached 76%.

Considerable experience has been accumulated in the use of powered supports made according to different design schemes and with different parameters for a variety of mining conditions. Despite this, until now there is no sufficiently coherent classification of them with a detailed consideration of all the most important classification features.

Below we propose a new classification scheme for powered supports- bench sets and sections, which is based on the following features.

All powered supports (bench sets) according to the composition of the sections are divided into the same type, two-type and multi-type.

According to the method of arrangement of sections, all powered supports are divided into three groups: with a linear arrangement of sections that move sequentially; with a staggered arrangement of sections (the movement of sections goes sequentially through one); with a group triangular arrangement of sections when one of the sections in each group moves sequentially (or simultaneously).

According to the method of movement of the downhole conveyor, powered supports are of two types: with the frontal movement of the conveyor and the movement of the conveyor with the bending of its flight (movement by "wave").

In the direction relative to the occurrence of the formation, powered supports are divided into moving along the strike, fall or rise.

According to the method of excavation and the sequence of movement of sections, powered supports are differentiated into one-sided, two-sided (shuttle) and group frontal ones.

According to the control method, powered supports can be made:

- with manual control, when the worker controls from a directly movable support section;

- with manual one-way remote control from the adjacent section; such control can also be two-way, which is very important for powered supports operating in thin layers;

- with manual remote control from a central console placed on the workings adjacent to the treatment face;

- with automated control.

Automated control can be within:

- sections, when the section is unloaded, moved and expanded automatically according to the initial impulse;
- groups of sections (group), when a certain group of sections is unloaded, moved and expanded according to the initial impulse;
- shop equipment, when, depending on the operation of the dredging machine, the sections of the support are fully automatically unloaded, moved and expanded along the entire length of the cleaning face.

According to the nature of the interaction with the roof rocks, all sections of the powered support are divided into four types (Fig. 1.2): supportive, supportive, protective and protective.

The supporting sections have an upper overlap, only supporting the roof rocks.

The supporting and protective sections combine a supporting element with a protective one, which prevents the collapsed roof rocks from entering the bottomhole workspace. In this case, the projection of the supporting part of the overlap on the plane of the base is greater than the projection of the enclosing part.

The protective and supporting sections consist of a supporting element that holds the roof rocks, and a protective element that protects the collapse of the roof rock into the bottomhole workspace. In this case, the projection of the enclosing part of the overlap on the plane of the base is greater than the projection of the supporting part.

The protective sections have only a protective element that protects the roof rocks from penetration into the workspace.

For interaction with the roof rocks, the type of upper floor is important. According to the structural scheme of the upper floor, all sections of powered supports are divided mainly into two types: with a rigid upper floor and a rigid-hinged upper floor. The presence of the latter makes it possible in some cases to improve the distribution of resistance of a section of powered support along the width of the workspace. To maintain the roof, especially in the bottomhole space, an important classification feature is the design of the upper ceiling console. The cantilever part of the upper ceiling is divided into four types: rigid, rigid-elastic with the presence of a spring element, rigid or rigid-elastic preload with a special hydropatron and rigid retractable, when there is a retractable element for operational maintenance of roof rocks in the bottomhole space (Fig. 1.3).

To eliminate the spillage of roof rocks into the side gaps between the support sections, the method of their overlap is important. According to this classification feature, the support sections can be made without overlapping the side gaps between the support sections, elements of forced-priming springs or hydraulic cylinders.

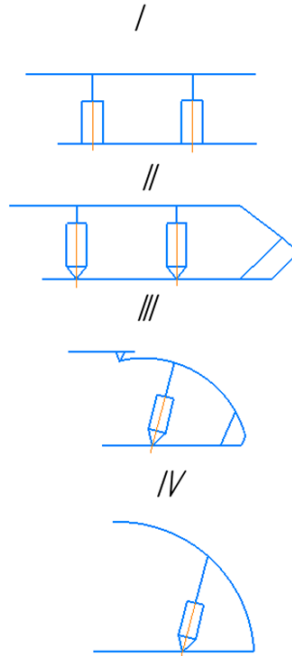

Figure 1.2. Sections of powered supports:
I - supporting; II - supportive and protective;
III - protective and supportive; IV - protective

According to the number of hydraulic racks and the scheme of their arrangement, sections of powered supports can be one-, two-, three-, four-, five- or six-column. Such a number of hydraulic racks can be arranged in one or two rows along the length of the cleaning face and in one, two or three rows along the width of the working space.

According to the number of movement jacks, all sections of powered supports can be made with one movement jack or with two. It is preferable to use two jacks, since in this case a more directional movement of the support sections is provided.

Extremely important is the classification feature that determines the force connection of the base with the overlap (Fig. 1.4). In the absence of such, it is difficult to move the support section with an active support. If it is available, it is possible to move the sections of the support with active support, which generally improves the interaction of the support with the roof rocks.

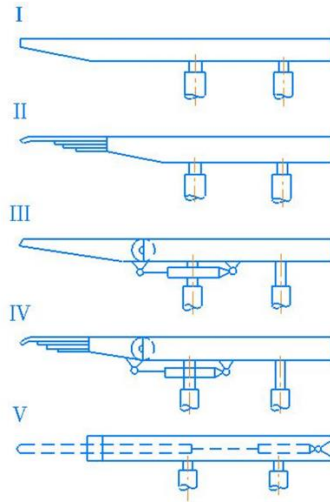

Figure 1.3. Structural schemes of the cantilever part of the supporting overlap:
I - rigid; II - elastic; III - rigid preload; IV - rigid elastic preload; V – retractable

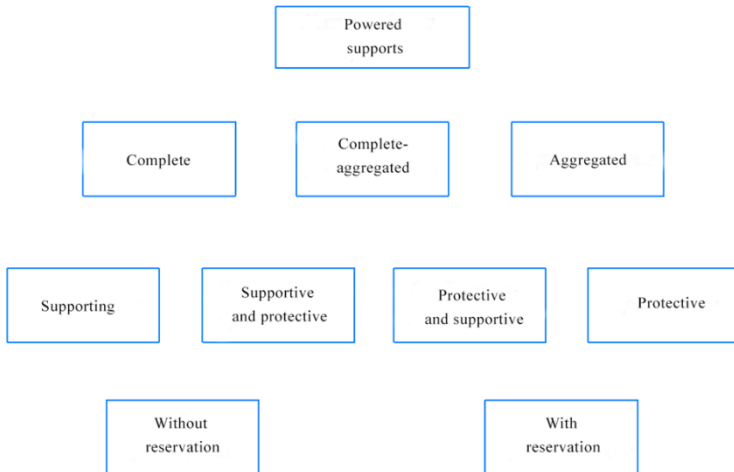

Figure 1.4. Classification table of powered supports

In accordance with this, all sections of powered supports are divided into three types according to the method of movement of the upper floor. The sections move with the separation of the upper floor from the roof rocks. This

is the worst way in which it is possible to dump pieces of roof rocks and get them into the workspace. The support sections move without losing contact of the upper floor with the roof rocks. This way is better. However, the method is effective when the support moves in a state of active support of the overlap (pressing) to the roof rocks. And, finally, the construction of the support sections is possible when the upper floor moves without unloading the hydraulic racks - the so-called non-unloading support sections. In this case, in the area of movement of the support sections, the working resistance of the support does not decrease, as noted in all other schemes.

Based on domestic and foreign experience in the development of powerful shallow coal seams, the following classification of powered supports can be compiled: supports with coal excavation within the working space; supports with the repayment of the upper layer; supports with machines for laying flexible floors.

The first type includes supports for the layered excavation of formations with an average capacity (OKP, ZOKP, OKP70, KM81, KM130, 2MK, ZMK), supports for single-layer combine excavation of formations with a capacity of up to 5 m (KM120, UKP), as well as supports for the excavation of powerful layers with a concave face shape with independent cleaning equipment, which, in turn, are divided into supports with advanced excavation of the upper (2KMP, MKP2U) and lower the bottom face, and the cleaning equipment - combines or plow working bodies in the upper and the combine in the lower face.

The second type includes supports with mechanized repayment of the upper stratum with the use of retractable working bodies, using BVR (KTU2MKE, CNC), with the release of coal of the upper stratum due to the forces of mountain pressure; with controlled release - Westphalia, KM81B, with uncontrolled - the support of the company "Mashinenfabrik Hermann Hemscheidt". Supports of the second type are used mainly for dredging layers with a capacity of 7-22 m in combined systems with flexible floor covering, as well as in systems with coal storage.

The third type includes supports that have machines for laying flexible floors (AMS).

The above classification features made it possible to create a classification table of both powered supports of treatment faces and their sections.

1.3. General principles of the design of powered supports

General rules of construction. When creating powered supports, it is recommended to adhere to the following rules:

- subordinate the design to the task of increasing the economic effect, determined primarily by the durability of the support and the cost of its operating costs for the entire period of use;
- maximize the useful return by increasing the performance of the support and the volume of operations performed by it;
- in every possible way to reduce the cost of operating the support by reducing the cost of maintenance and repair;
- maximize the degree of automation;
- to increase the durability of machines in every possible way as a means of increasing the actual number of the machine fleet and its total useful output;
- to prevent the technical obsolescence of supports, ensuring their long-term applicability, laying high initial parameters in them and providing reserves for development and consistent improvement;
- to lay the prerequisites for the intensification of use in operation in the design by increasing their versatility and reliability;
- provide for the possibility of using structural elements of the base support;
- to reduce the number of standard sizes of supports, achieving satisfaction of the needs of the national economy with a minimum number of models by rational choice of their parameters and increasing operational flexibility;
- to meet the needs of the national economy with minimal production of machines by increasing their useful output and durability;
- to design supports with the expectation of maintenance-free operation with the complete elimination of major repairs and replacement of restoration repairs with a complete set of replaceable units;
- consistently maintain the principle of aggregativeness; design independent units installed on the section in assembled form;
- exclude the selection and fitting of nodes during assembly and installation;
- exclude reconciliation operations, adjustment of parts and assemblies in place; provide fixing elements in the design to ensure the correct installation of parts and assemblies during assembly;
- to ensure high strength of parts and supports in general in ways that do not require an increase in weight (giving rational shapes to parts with the best use of material; the use of high-strength materials; the introduction of hardening treatment);
- pay special attention to increasing the cyclic strength of parts, give them forms that are rational in terms of fatigue strength; reduce stress concentration; introduce fatigue-hardening treatment;

- introduce elastic elements that soften shocks and load fluctuations into the elements of the section operating under cyclic and dynamic loads;
- to give high rigidity to structures by expedient methods that do not require an increase in mass (the use of hollow and shell structures; blocking deformations by transverse and diagonal connections; rational arrangement of supports and stiffness units);
- in every possible way to increase the operational reliability of the support, achieving, as far as possible, complete reliability of its actions;
- reduce the volume of maintenance operations, eliminate periodic adjustments in structures;
- to prevent the possibility of overvoltage by introducing automatic regulators, safety devices that exclude the possibility of using the support in dangerous modes;
- eliminate the possibility of breakdowns and accidents as a result of inept or careless handling of supports; introduce locks that prevent the possibility of improper manipulation of controls;
- eliminate the possibility of incorrect assembly of parts and assemblies that need precise coordination one relative to the other;
- to reduce the cost of manufacturing machines by making structures technologically advanced, unification, normalization, reduction of metal consumption, reduction of the number of standard sizes of machines;
- reduce the weight of the support by increasing the compactness of structures, using rational kinematic and power schemes, eliminating unprofitable types of loading, replacing bending by stretching by compression, as well as using light alloys and non-metallic materials;
- simplify the construction of the support in every possible way; avoid complex multi-part structures;
- to ensure maximum manufacturability of parts, assemblies and sections as a whole, laying the prerequisites for the most productive manufacturing and assembly in the design;
- to unify the structural elements of the section as much as possible in order to reduce its cost, reduce the production time, fine-tuning, as well as facilitate operation and repair;
- to expand the use of normalized parts in every possible way to comply with the current state standards, the sectoral state body, industry norms, limits on the applicability of normalized elements;
- do not use original parts and assemblies where standard, normal, unified, borrowed and purchased assemblies can be dispensed with;
- save expensive and scarce materials by using their full-fledged substitutes; if it is inevitable to use scarce materials, reduce their consumption to a minimum;

- to give the support simple and smooth external forms that facilitate its maintenance and care for it.
- concentrate the control and control body, if possible, in one place convenient for viewing and manipulation;
- to make available and convenient for inspection the components and mechanisms of the support that need periodic inspection;
- to ensure the safety of service personnel; to prevent the possibility of accidents by maximizing the automation of work operations, the introduction of locks and the installation of protective fences;
- carefully study the experience of using supports and promptly introduce into the design corrections of defects found in operation; operation is the best means of improvement and fine-tuning, as well as an effective way to improve the skills of the designer;
- continuously improve the design of supports in mass production, keeping them at the level of increasing industry requirements;
- to provide a constructive foundation, preparing the release of new supports with higher indicators to replace outdated ones;
- conduct advanced design, designed to meet the long-range casts of production;
- when designing new structures of powered supports designed for new technological processes, check all new elements with the help of experiment, modeling, advance manufacturing and testing of components;
- to make wider use of the experience of executed structures, adjacent, and, in necessary cases, remote branches of mechanical engineering [4].

Economic fundamentals of design. The economic factor plays a primary role in the design. Particular designs should not obscure the main purpose of construction - to increase the economic effect of new mining equipment.

Many designers believe that to design economically means to reduce the cost of manufacturing the support, to avoid complex and expensive solutions, to use the cheapest materials and simple manufacturing methods, This is only a small part of the task. The main importance is that the economic effect is determined by the value of the useful return of the equipment and the amount of operating costs for the entire period of operation of the support.

Economically oriented design should take into account the whole complex of factors and correctly assess their relative importance. This rule is often ignored. In an effort to reduce the cost of products, the designer often achieves savings in one direction and does not notice other, much more effective ways to increase efficiency. Moreover, private savings, carried out

without taking into account the totality of all factors, often leads to a decrease in the total efficiency of new equipment.

The main factors determining the efficiency of new equipment are the value of its useful output, durability, reliability, labor costs, energy consumption and the cost of repairs.

Durability of the support structure, like the useful return, it very much depends on the conditions and technical level of operation. Careful attitude to the support, timely prevention significantly increase its durability. Low maintenance reduces the service life of the support. However, the correct design of modern powered supports is crucial for durability.

Durability criteria. Durability is the total time that the support can work out in normal operation without significantly reducing the main design parameters, with an economically acceptable total cost of repairs.

In many cases, especially for aggregates, durability is measured by indicators of the total output for the entire time of operation of the unit. The durability determined in this way is the total number of operations or unit of work that the support or unit can produce before extreme wear.

The service life of the support is the total duration of its stay in operation (in years) until the resource of durability is exhausted. For the support, the service life is defined as the quotient of the division of durability, expressed by the number of operations (units of work), by their average number per year.

The theory of durability. At the stage of formation is the theory of durability, the subject of which is:

- determination of technically and economically feasible durability limits;
- development of methods for studying the operation of powered supports (statistical processing of operational information);
- study of operational modes and their impact on the durability of supports; typification of the spectra of operational modes;
- determination of the degree of use of supports in operation and the relationship between durability and service life of supports;
- diagnosis of the causes of destruction;
- identification of parts that limit durability and the effect of the durability of parts on the durability of supports as a whole;
- development of methods of bench and shaft tests of the support and its components; forecast of operational durability of the support based on bench tests;
- development of objective indicators of durability of serial powered supports, etc.

The multiplicity and heterogeneity of factors affecting durability (technical level of operation, fluctuations in operating conditions, manufacturing quality, etc.), the uncertainty of many factors (dispersion of strength characteristics of materials, the influence of regional and climatic conditions, etc.) force us to resort to probability theory and mathematical statistics when determining durability. The theory does not give an unambiguous answer to the question of expected durability, limiting itself to establishing functional dependencies of the probability of destruction on the duration and modes of operation. According to it, it can be assumed that the probable duration of the support in this mode will be, say, 8, 12, 18 thousand hours with a probability of destruction of 90, 80 and 60%, respectively, or to establish the probable number of sections remaining in operation (percentage of survival) after certain periods of operation.

The type and volume of damage must also be taken into account, i.e. it has been revealed with a certain degree of certainty whether vital or secondary parts and assemblies are being destroyed, whether the maintainability of the support remains, what is the likely volume and cost of repairs? From these positions, durability can be defined as the probable duration of the support in a regulated mode, in which the possible failure of the support is no more than a given conditional limit (for example, 10%), while maintaining the maintainability and the probable cost of repair, not exceeding a certain amount, expressed, for example, as a percentage of the cost of the support.

Means of increasing durability. The main factors limiting durability are the following: breakdowns of parts; damage to surfaces as a result of contact stresses; plastic deformations of parts caused by local or general stress transition beyond the yield point or creep.

Strength in most cases is not an insurmountable limit. With the currently available assortment of machine-building materials, existing manufacturing methods, and the current state of strength science, there are no parts in the supports that could not be given almost unlimited durability.

Limits of increasing durability. Technically achievable durability largely depends on the degree of operation of the support. The durability of the support can be artificially extended by restorative repairs. However, this way is economically impractical, since sometimes the cost of restoration repairs is many times higher than the initial cost of the support.

In the initial period of operation, repair costs are low. Then they increase by leaps and bounds with the current and average repairs and, finally, reach significant sizes.

When deciding on the termination of operation, the total cost of all previously performed repairs should be taken into account. As an indicative

rule, it can be assumed that the total repair costs for the entire period of operation of the support should not exceed its cost.

Durability and technical obsolescence. The increase in durability is closely related to the problem of technical obsolescence of supports, which occurs when the support, while maintaining physical performance, ceases to satisfy the industry due to increased requirements or the appearance of more advanced supports.

Signs of obsolescence are reduced in comparison with the average level of reliability, product quality, duration, cost of labor, maintenance and repairs, and as a general result - reduced profitability of the support. The main consequence of obsolescence is a decrease in productivity growth per unit of labor, which is the main indicator of economic progress.

Unconditional obsolescence occurs in two cases: with a complete change in the technological process; with the opening of new workflows or the appearance of fundamentally new design schemes that surpass the old models of supports in terms of indicators. However, such radical and rapid changes do not occur often.

The main thing is the construction of supports taking into account the dynamics of the development of the coal industry. In the design of the initial model, reserves of productivity, power, useful returns, and the range of operations performed should be laid down, which will make it possible to consistently modernize the support and maintain its performance at the level of increasing technical requirements without changing the main model and, consequently, without breaking production, which is inevitable when switching to the release of a new model.

The most effective means of preventing obsolescence is increasing the degree of use of supports in operation. The shorter the time the support fulfills the durability resource embedded in it, i.e. the service period is closer to durability, the more likely it is insured against obsolescence.

Reducing the service period to 3-4 years practically guarantees the support from obsolescence.

The task of reducing the service life with constant durability is reduced to the full intensification of the use of supports, i.e. the most important is an increase in the number of working shifts and an increase in the degree of loading.

The main design prerequisites for intensification are: universalization, i.e. expansion of the scope of application of the support; increasing the reliability of the support, leading to a reduction in emergency and repair downtime.

The reliability of the support structure consists of the following features: high durability, trouble-free operation, trouble-free operation,

stability of action (the ability to work for a long time without reducing the initial parameters), endurance (the ability to withstand overloads), small volume of maintenance operations, survivability (the ability to continue working for some time with partial damage, at least at reduced modes), damage fixability (preservation of maintainability), long repair periods, small amount of repair work [5].

The variety of features that determine reliability makes it difficult to single out its single criterion. Most often, when determining reliability, they proceed from the concept of failure, i.e. any forced stop of the treatment face.

The reliability of the support can be characterized by the frequency of failures, the duration of uninterrupted operation between failures, the regularity of changes in the frequency of failures over the service period, the severity of failures, the volume, cost and duration of work required to eliminate failures.

According to the severity of failures, they are divided into light, medium and heavy.

Light failures are minor malfunctions that are eliminated by the maintenance personnel.

Average failures are malfunctions and damages that require a prolonged stop of the face, partial disassembly, replacement (or restoration) of damaged section parts, carried out with the involvement of repair services.

Severe failures are accidents affecting the vital organs of the support and requiring a long stop for repair.

By origin, there are failures caused by structural and technological defects, improper operation and accidental.

The reliability of the supports can be characterized by the amount of work to eliminate failures, i.e. ultimately an indicator of the cost of repairs, comprehensively reflecting the frequency and severity of failures and its maintainability.

Ways to improve reliability. The reliability of the supports is primarily determined by the strength of its construction. Rational ways to increase strength, which do not require an increase in weight, are the use of advantageous profiles and shapes, maximum use of the strength of the material, and, if possible, uniform loading of all structural elements of the support.

Expedient ways to increase rigidity are the correct choice of the loading scheme, rational placement of supports, giving rigid shapes to structures.

The trouble-free operation and the duration of the overhaul periods largely depend on the correct operation, careful attitude to mining equipment, careful care, timely prevention.

But it would be wrong to rely entirely on the quality of service. The conditions for proper operation of the support must be laid down in its design. It is necessary to ensure reliable operation even in conditions of insufficiently qualified service. If the support sections deteriorate in inept hands, it means that the design is not well thought out.

In the complex of measures that ensure the operational reliability of the supports, an important role is played by automatic protection against accidental or intentional overloads by safety devices operating in the guarding mode and coming into effect when the supports are overloaded.

The most expedient is full automation of control, i.e. the transformation of the support into a self-servicing, self-regulating and self-adjusting unit for optimal operation.

High reliability of the support can be achieved only by a complex of constructive, technological and organizational and technical measures. Improving reliability requires long-term, scrupulous, purposeful joint work of designers, technologists, experimenters and production workers, conducted according to a carefully developed and consistently implemented plan.

It is necessary to apply more widely the method of modeling operational conditions, which consists in bench or operational tests of supports in conditions that are obviously more severe than normal operation.

Finishing of the support in operation. In order to create reliable and durable supports, it is necessary to carefully study the operating experience. The work of design organizations on the support should not end with state tests of the prototype and the delivery of the machine into mass production.

The finishing of the support really begins only after its commissioning. Operational inspection is the best way to detect and eliminate weaknesses in the design.

The disadvantages of the support are especially clearly clarified during repair, therefore, a close and continuous communication of the designer with repair enterprises is mandatory, it is useful for manufacturers of mass and large-scale products to have their own repair units as laboratories for studying the supports.

When studying defects, it is necessary to distinguish random defects from systematic ones. The former are usually caused by unsatisfactory control and insufficient technological discipline at the manufacturer, the latter indicate unsatisfactory design and require immediate corrections to the manufactured supports.

The unification and normalization of parts, supports and assemblies gives a great economic effect.

Unification consists in the repeated use of the same elements in the design, which helps to reduce the range of parts and reduce the cost of manufacturing, simplify the operation and repair of mining equipment.

Normalization is the regulation of the design and standard sizes of widely used machine-building parts, support units and aggregates.

Almost every specialized design organization normalizes typical parts and assemblies for this branch of mechanical engineering. Normalization accelerates the design, facilitates the manufacture, operation and repair of supports and, with the appropriate design of normalized parts, increases the reliability of supports.

1.4. Design methodology of powered supports

The initial materials for the design can be the following: the technical specification issued by the planning organization, the parent institute or the customer, and the defining parameters of the support, the scope and scope of its application;

- scientific research work or an experimental sample created on its basis;
- an inventive proposal or an experimental sample based on it;
- a sample of foreign powered support to be copied or reproduced with alterations.

The first case is the most general: it is the most convenient way to trace the design process. It is necessary to approach technical tasks critically. The designer should know well the coal industry for which he designs the support. He is obliged to check the assignment and, if necessary, reasonably prove the need for its correction.

A critical approach is especially necessary when the customer is the coal industry. In this case, along with meeting the customer's requirements, it is also advisable to provide the possibility of using the support in various mining and geological conditions.

They do not always take into account the fact that from the moment of the beginning of the design to the introduction of the support into the industry, a certain period passes, as a rule, the longer the more complex the support. This period consists of the following stages: design, manufacture, factory debugging and fine-tuning of the prototype, industrial tests, making alterations revealed during the tests, state tests and acceptance of the prototype. This is followed by the preparation of technical documentation of the head series, its manufacture and industrial testing. After that, serial documentation is developed, production is prepared for serial production and, finally, serial production is organized.

At best, in the absence of major problems and complications, this process lasts three to four years. Sometimes five to six years, or even more, pass between the beginning of the design and the beginning of the serial production of the support. At the current pace of technological progress in mechanical engineering, this is a long time.

Supports with incorrectly selected, understated parameters, based on technical solutions that do not provide technical progress, incompatible with new ideas about the role of quality, reliability and durability, become obsolete by the beginning of serial production. The work spent on designing, manufacturing and fine-tuning the sample turns out to be in vain, and the industry does not receive the necessary equipment.

Constructive continuity is the use in the design of the previous experience of mechanical engineering of this profile and related industries, the introduction into the projected unit of all the useful things that exist in existing structures of supports. Almost every modern support represents the result of the work of designers of several generations. The initial model of the support is gradually being improved, equipped with new nodes and enriched with new constructive solutions, which are the fruit of the creative efforts and ingenuity of subsequent generations of designers. Some constructive solutions, with the advent of more rational solutions, new technological techniques, with increased operational requirements, die off, while others turn out to be exceptionally tenacious and persist for a long time in such or almost such a form as their creators gave them.

Over time, the technical and economic indicators of the supports increase, their reliability and durability increase, new supports of the same purpose appear, but fundamentally different design schemes. The most progressive and tenacious constructions win the competition.

It is especially important to study the initial solutions when developing a new design. The main part is the correct choice of the support parameters. Particular design errors can be corrected during the manufacturing and finishing of the support.

The selection of parameters should be preceded by a complete study of all factors determining the viability of the support. It is necessary to study the experience of creating foreign and domestic supports, conduct a comparative analysis of their advantages and disadvantages, choose the right prototype, find out development trends.

Scope of application of supports. The coal industry is undergoing a process of continuous improvement: the volume of coal production is growing, the duration of the production cycle is shortening, new technological processes are emerging, the layout, composition and arrangement of equipment is changing, the level of mechanization and

automation of production is continuously increasing. Accordingly, the requirements for the indicators of downhole equipment, their productivity, and the degree of automation are increasing. Some supports become unnecessary with the advent of new technological processes. There is a need to create new supports or radically change the old ones.

The design of new systems of powered supports designed for certain conditions should be preceded by a thorough study of the dynamics of its quantitative and qualitative development, the needs in this category of supports and the likelihood of the emergence of new technological processes and production methods [7].

When choosing the parameters of the support, it is necessary to take into account the specific conditions of its use. It is impossible, for example, to arbitrarily increase the productivity of a combine without taking into account the performance of adjacent equipment. In some cases, combines with increased productivity may be underloaded in operation and will be idle more than they work. This will reduce the degree of their use and reduce the economic effect of using a mechanized complex.

The choice of design. When choosing the parameters of the support, the main scheme and the type of construction, the focus should be on the factors that determine economic efficiency: high efficiency, low maintenance costs, low cost and long service life. The support scheme is usually chosen by a parallel analysis of several options that are subjected to a thorough comparative assessment from the side of constructive expediency, perfection of kinematic and power circuits, cost of manufacture, reliability of action, dimensions, metal consumption and weight, manufacturability, ease of maintenance, inspection, installation and disassembly.

It is necessary to find out to what extent the scheme provides the possibility of further development, forcing and improvement of the support, the formation of new supports and modifications based on the original model [9].

It is not always possible, even with the most thorough searches, to find a solution that fully meets the requirements. An impeccable option in all respects in design practice is a rare success. Sometimes it's not a lack of ingenuity, but the inconsistency of the requirements put forward, In such cases you have to compromise and give up some of them. Often the option is chosen, not so much having the greatest dignity, as having the least disadvantages.

After selecting the scheme and the main indicators of the new equipment, a layout is developed, on the basis of which draft, technical and working projects are made.

The development of options is not a matter of individual habits or inclinations of the designer, but a natural design method that helps to find the most rational solution.

The inversion method. Among the techniques that facilitate the complex work of designing, the inversion method occupies a prominent place - the reversal of functions, shapes and the location of parts [8].

In nodes, it is sometimes advantageous to change parts by roles, for example, to make the leading part driven, the guide - guided, the covering-covered, the stationary -movable. The designer's job is to weigh the advantages and disadvantages of the original and inverted variants, taking into account the strength, manufacturability, ease of operation and choose the best of them. For an experienced designer, the inversion method is an integral tool of thinking and greatly facilitates the process of finding solutions, as a result of which a rational design is born.

1.5. Design of mechanical supports on the basis of unification

Unification is an efficient and economical way to create, based on the original model, a number of powered supports of the same purpose, but with different power, performance, etc., or for different purposes, performing qualitatively different operations.

Currently, there are several ways to solve this problem. Not all of them are universal. In most cases, each method is applicable only to certain types of supports, and their economic effect is different.

The following classification of methods for creating powered supports is conditional. Some of these methods closely overlap with each other; it is difficult to draw a strict boundary between them. A combination and parallel application of two or more methods is possible.

Partitioning. The method of partitioning consists in dividing powered supports into identical sections and forming sets of unified sections.

Many types of transport vehicles (belt, scraper and chain conveyors) also lend themselves well to partitioning. Partitioning in this case is reduced to the construction of a machine frame from sections and the compilation of machines of various lengths with a new load-bearing web.

The cost-effectiveness of the formation of supports in this way suffers little from the introduction of separate non-standard sections that may be needed to lengthen the supports in various field conditions.

Method of changing linear dimensions. With this method, in order to adapt the support to various mining and geological conditions and obtain different productivity of mechanized complexes and aggregates, their length is changed, while maintaining the shape of the cross section.

The degree of unification with this method is small. Only the end sections and other auxiliary nodes are unified. The main economic gain is the preservation of the main technological equipment for the extraction of coal in the treatment face.

The method of the base unit. This method is based on the use of the base support of the unit for various purposes with the connection of special equipment to it. The latter requires the development of additional mechanisms and devices, which, in turn, can be largely unified.

Conversion. When converting, the base nodes of the support or its main elements are used to create supports for various purposes, sometimes close, and sometimes different in the workflow. An example of conversion can be the use of an overlap or the base of supports of a supporting type to create powered supports of preparatory workings or supports of interfaces.

Compounding. The compounding method (parallel connection of various types of supports) is used to increase the completeness of coal excavation when the reservoir capacity changes. The paired supports can either be installed side by side as independent, or connected to each other by synchronizing transport devices, or, finally, structurally combined into one support.

Modification. Modification is the alteration of the support in order to adapt it to other working conditions without changing the basic structure. Modification of the support for work in various mining and geological conditions is mainly reduced to the replacement of materials.

Universalization aims to expand the functions of powered supports, increase the range of operations performed by them, expand the scope of their application. It increases the adaptability of supports to production requirements and increases their utilization rate. The main economic significance of universalization lies in the fact that it reduces the number of production facilities. One universal support replaces several specialized ones that perform separate operations.

It is possible to expand the functions and areas of application of supports by introducing additional working bodies, giving replaceable equipment, introducing regulation to increase the removed reservoir capacity, regulating the main indicators (capacity, productivity, etc.).

1.6. Construction of units and parts of the section powered supports

Unification of structural elements. The elements revealed during the layout process should be repeatedly used for the entire structure, using the calculated parameters, achieving the maximum reduction of their nomenclature. The landing joints and fastener are primarily subject to

unification. It is advisable to reduce the nomenclature of materials, types of finishing operations, types of welding, the shape of welds, etc.

Unification of details. It is necessary to achieve maximum unification of the original parts. This is especially important for time-consuming and repetitive support parts.

Compact design. One of the signs of a rational design is compactness. The expedient use of volume reduces the size, weight, and metal consumption.

The principle of self-adjustment. In movable joints, where distortions and displacements of parts are possible, it is necessary to provide for freedom of self-adjustment, ensuring the correct operation of parts with all possible inaccuracies in manufacturing and installation.

Bombing. Surfaces operating under load in linear or planar contact conditions should be slightly convex, which ensures the central application of the load and eliminates increased edge pressures arising from manufacturing and installation inaccuracies. This technique is widely used for parts operating under high load in conditions of friction or sliding.

Axial fixation of parts. The parts should be fixed in the axial direction only at one point, providing for the possibility of their self-installation along the rest of the length. For example, in the correct design, the finger is fixed with only one end, the opposite end can move in the support.

Keeping details along with the guides. Parts that make a rectilinear forward-backward movement along two guides should be fixed on one guide; the second guide should only support the part. Simultaneous double direction places increased demands on the accuracy of manufacturing guides and grooves.

The sealing surfaces for removable parts should be made flat, and also avoid mounting on a cylindrical surface. The manufacture of such compounds is very laborious. The sealing surface of the detachable parts must be processed in a device that ensures equality of the sealing surfaces of the part and the housing.

1.7. General principles of section layout of the powered supports

The layout usually consists of two stages: sketch and working. In the sketch layout, the basic scheme and the general design of the support are developed (sometimes several options). Based on the analysis of the sketch layout, a working layout is made that clarifies the design of the support section and serves as the starting material for further design.

During the layout, it is important to be able to highlight the main thing and establish the correct sequence of the design of the support. An

attempt to put together all the structural elements of the support at the same time is a mistake that is characteristic of novice designers. Having received a task defining the purpose and parameters of the designed support, the designer often begins to immediately draw the structure as a whole in all its details, with a full image of the structural elements, giving the layout a look that should only have an assembly drawing of the structure in a technical or working project. To design this way means almost certainly to condemn the design to irrationality. It turns out mechanical stringing of structural elements and assemblies that are obviously inexpedient.

The layout should begin with solving the main issues - choosing rational kinematic and power schemes of the support, the correct size and shape of the section parts, determining the most appropriate mutual arrangement of them. When assembling, it is necessary to go from the general to the particular, and not vice versa. Finding out the details of the design at this stage is not only useless, but also harmful, since it distracts the designer's attention from the main tasks of the layout and knocks down the logical course of design development.

Another basic rule of layout is the development of options, their in-depth analysis, and the choice of the most rational of them. It is a mistake if the designer immediately sets the direction of construction, either by choosing the first type of construction that came to mind, or by taking a template design as a sample. First, you need to think through all possible solutions and choose the optimal one for these conditions. This requires labor and is not given immediately, and sometimes as a result of long searches.

During the layout process, it is necessary to make calculations, at least approximate and approximate. The main details of the structure must be designed for strength and rigidity. It is impossible to trust the eye when choosing the sizes and shapes of parts. However, there are experienced designers who almost accurately set the dimensions and cross-sections that ensure the stress level accepted in this branch of engineering. But this dignity is doubtful.

It is wrong to rely entirely on calculation. Firstly, the existing methods of strength calculation do not take into account the factors that determine the operability of the structure. Secondly, there are details that cannot be calculated (for example, complex housing). Thirdly, the required dimensions of the parts depend not only on the strength, but also on other factors. The design of cast parts is determined primarily by the requirements of casting technology.

The dimensions of the control parts should be chosen taking into account the convenience of manipulation. A necessary condition for proper design is to constantly keep in mind the issues of manufacturing and the

selection of technologically appropriate forms. An experienced designer, composing a part, immediately makes it technologically advanced.

The layout must be based on the normal dimensions. At the same time, it is necessary to achieve maximum unification of normal elements, Elements that are unavoidable in the design of the main parts and assemblies are recommended to be used in other parts of the structure.

During the layout, all the conditions that determine the operability of the support must be taken into account.

Sometimes the designer involuntarily loses objectivity, ceases to see the disadvantages of the option he likes and the possibilities of other options. In such cases, it is necessary to resort to the advice of production workers and operators. The broader the discussion of the layout and the more carefully the designer listens to useful advice, the better the layout becomes and the more perfect the design turns out.

You should not spare time and effort to work out the project. The cost of design work is a small fraction of the cost of the support. A deeper study of the design ultimately gives a gain in cost, terms of manufacture and refinement, quality, and magnitude of the economic effect of powered support.

Layout technique. The layout is best done on a scale of 1: 1 if the overall dimensions of the projected object allow. At the same time, it is easier to choose the necessary dimensions and sections of parts, to get an idea of the proportionality of the parts of the structure, the strength and rigidity of the parts, and the structure as a whole. In addition, such a scale eliminates the need for setting a large number of sizes and facilitates subsequent design processes, in particular detailing. The dimensions of the parts, in this case, can be taken directly from the drawing.

Drawing on a reduced scale, especially with reductions exceeding 1: 2, greatly complicates the layout process, distorting the proportions and depriving the drawing of clarity, If the dimensions of the support do not allow applying a scale of 1: 1, then, in any case, its individual nodes should be assembled in kind.

1.8. Basic mining and geological requirements for powered supports

Powered support, being one of the main functional machines of the means of mechanization of coal excavation, at the same time significantly affects the choice of the type of both the dredging machine and the downhole conveyor.

When choosing powered support, it is necessary first of all to assess its compliance with the main mining and geological factors: the thickness and

angle of fall of the formation, its gas content and geological disturbances, physical and mechanical properties of lateral rocks, and rock pressure.

The reservoir capacity and its change within the excavation field determine the standard size of the support. When working on thin layers (0.5-1.2 m), special requirements are imposed on the relative extensibility of the support. If the relative extensibility of 1.4-1.6 is sufficient for medium-thickness formations (1.2 -3.5 m), then for thin layers it should be 1.8- 2.2 due to the presence of large deviations in reservoir capacity. When developing formations with a capacity of more than 2.5 m, there is often a difficult problem of controlling the bottom of the face in order to keep it from collapsing as a result of pressing. In these conditions, it is advisable to work on the fall of the formation or to use supports with active devices to hold the breast of the face.

The angle of incidence of the formation determines the need to use special devices that keep both the support and all the equipment of the complex in the face from sliding under its own weight. When developing inclined layers (25-30°), the powered support must have special design solutions to keep sections and conveyor or grid flights from sliding. The sliding of the support begins almost at angles of incidence over 10-12°. When developing steep-falling layers (more than 35 °), it is necessary to have special retaining elements. It is advisable to combine the retention function with the control of the sections by falling and with partial support of the equipment on the inclined breast of the face.

Geological disturbances often limit the effectiveness of the use of powered supports due to the need to reduce the length of the excavation field, the variable length of the face, impassable areas in places of sharp pinching of drownings, and discharges of formations. The choice of powered support by the width and length of the sections and by the type of base is strongly influenced by the hypsometry of the formation both in stretch and in fall.

The gas content of the formation imposes special requirements on the powered support since its structural dimensions determine the cross-section of the free working space for the passage of air. Its value is found from the condition

$$S_{avg} \gg \frac{1000Qnq_0}{V_{max}dkvp}, \quad (1.1)$$

where S_{avg} the actual free cross-section of the workspace, m^2 ; Q - theoretical productivity of the mining machine, t/s ; p - the coefficient of natural degassing of the formation; q_0 - relative methane abundance of the reservoir under development, m^3/t ; V_{max} - the maximum permissible speed

of air movement through the face, which is 4 m/s; d - permissible concentration of methane in the outgoing jet, 1 % CH₄; K_{v-p} - a coefficient that takes into account the movement of air through the developed space, 1 - 1,5.

The number of gas-heavy mines is growing due to the transition of mining operations to great depths and currently exceeds 45% of the total number of mines.

The physical and mechanical properties of rocks and rock pressure determine the passport of the cleaning face attachment and the method of roof management. According to the scale of the former All-Union Coal Research Institute, which has become the most widespread, roofs are divided into four classes:

Class I - unstable rocks (easily collapsible rocks with a thickness of more than 6-8 times the thickness of the formation lies in the immediate roof);

Class II - stable rocks (in the immediate roof there are easily collapsible rocks with a thickness of less than 6-8 m, in the main roof - hard-to-break rocks);

Class III - very stable rocks (hard-to-break rocks lie in the immediate roof);

Class IV - very stable rocks capable of smooth deflection.

Powered supports can be used for roofs of I, II, IV classes and for roofs of III class in long words if the direct roof collapses in blocks after 5-6 cycles.

The presence in the immediate roof of layers of medium thickness of easily collapsible rocks with a thickness of less than 6-8 times the thickness of the formation in most cases leads to secondary precipitation of the main roof if it is represented by powerful sandstones or limestones, which significantly reduces the service life of the support and its reliability and leads to the destruction of the support in the event of a powerful mountain impact. Secondary sediment, as a rule, is excluded during the primary planting of direct roof rocks equal to 7-8 times the reservoir capacity.

When operating complexes on very stable rocks, it is necessary to use powered supports with a working resistance of 1000-1500 kN/m^2 .

The instantaneous rate of displacement of the roof, which can reach 0.2 m/s or more, which should be provided by the hydraulic system of the support, has a great influence on the choice of the support and the reliability of its operation. In the plane of the formation, the roof can shift by 20-25 mm or more per cycle, which must be compensated by the transverse pliability of the support.

The protective and supporting support works most effectively with very unstable roofs. With stable roofings, supporting support is used with a

working resistance along the landing row of $7 \cdot 10^5$ N/m on medium-power layers and $5 \cdot 10^5$ N/m on thin layers. In weak soils with little resistance to indentation (clay, sand, etc.), special support with a specific pressure of up to $8 \cdot 10^4$ N/m³.

An important characteristic of the support is the roof overlap coefficient, which is the ratio of the area of the upper overlap to the area of the supporting roof rocks. For loose and prone to peeling of the roof, the overlap coefficient is needed close to one.

In view of significant fluctuations in the power of coal seams (up to 10-15% on medium-power layers and up to 20-30% on thin steep layers), the standard size of the support should be chosen based on actual data on the removed reservoir power and its fluctuations, the values of lowering the roof at various distances from the bottom of the face.

Lowering of the roof at the front row of downhole racks (Fig. 1.5) is determined depending on the thickness of the formation:

$$h_b = \alpha m_{max} l_b \quad (1.2)$$

at the landing row of racks:

$$h_l = \alpha m_{min} l_l \quad (1.3)$$

where α is a coefficient that takes into account the roof class; l_b , l_l is the distance from the face to the bottom and landing posts, respectively.

The values of the coefficient α for the roof classes are as follows:

<i>Basin</i>	I	II	III
<i>Donetsk, Kuznetsk,</i>			
<i>Kizelovsk</i>	0,040	0,025	0,015
<i>Karaganda</i>	0,05-0,1	0,04	0,02-0,04

The minimum structural height of the support is determined at the greatest distance of the last landing row of racks from the face l_p :

$$H_{min} \ll m_{min} \cdot (h_l + \theta) = m_{min} - (\alpha m_{min} l_l + \theta) \quad (1.4)$$

where θ is the constructive landing size.

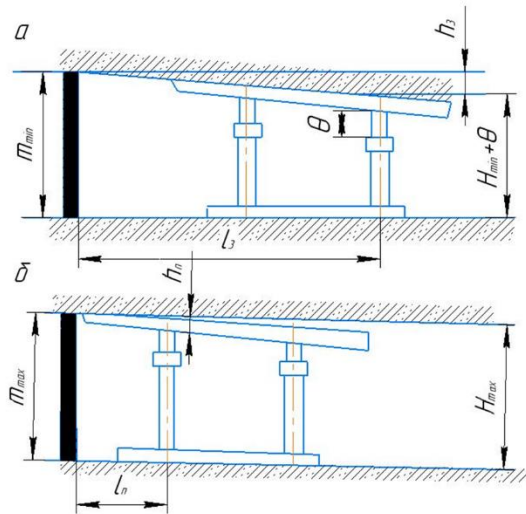

Figure. 1.5. The design scheme for choosing the minimum (a) and maximum (b) structural height of the support

The maximum structural height of the support should be determined by the upper value of the expected reservoir capacity:

$$H_{max} = m_{max} - \alpha m_{max} b \quad (1.5)$$

The amount of displacement of the roof at a distance of 4 m from the bottom of the face for sandstones and clay shales at the values of the tensile strength of 20 and 30 MPa, respectively, and the modulus of elasticity of 2-104 and 1.5-105 MPa, depending on the depth of development, can be taken as follows:

Development depth, m

Roofing displacement, mm	100	200	500	600	800	1200
Sandstones	34	50	70	80	85	90
Clay shales	62	78	106	125	138	142

1.9 Basic layout dimensions of treatment complexes with powered supports

When developing the layout scheme of treatment mechanized complexes, the minimum reservoir capacity and the range of its changes, the nature of the formation occurrence, the strength of soil rocks, the gas content of the formation, etc. are taken into account [40, 46].

Figure 1.6 shows a transverse section of the face with the main subsystems of the complex, Letter indexes indicate the defining linking dimensions. The indexes in the framework refer to the sizes that are stipulated by GOST 165-71 and 11986-73. All diagrams show the actual size values for the considered equipment complexes.

The dimensions of the space for the passage of people under the powered support should correspond to the physiological capabilities of a person when performing operations for the management and maintenance of machines and mechanisms. Studies of the Donetsk Research Institute of Occupational Hygiene and Occupational Diseases have established that the simple movement of a person along a 400 mm high aisle belongs to the category of heavy and super-heavy work. With a passage height of 500 mm and the speed of a person moving through the face (with all necessary operations performed) no more than 0.05 m / s, its voltage does not exceed the limits typical for medium-gravity work.

Based on these studies, the minimum height of free passage under the sections of powered support is recommended to be at least 500 mm.

The dimensions A and D, taking into account the thickness of the overlap, determine the gap B between the body of the combine and the overlap. An increase in the size of the B provides normal conditions for moving the combine, taking into account the restless hypsometry of the soil and the roof of the formation, changes in its capacity, conveyor shading, moving the combine in the vertical plane during operation, hardening of pieces of coal and rock.

An increase in gap B is possible either with an increase in the size D or with a decrease in size A. However, an increase in D leads to an increase in the minimum limit of the removed reservoir capacity.

Reducing the size of A is possible by reducing the size of G and Zh, as well as improving the cleaning of the soil of the formation. The value of G is determined by the height of the engine according to GOST 165-71, which, in turn, is linked to its power. Obviously, reducing the height of the engine body will lead to a decrease in its power, the minimum value of which for each size of combines is stipulated by GOST 11986-73.

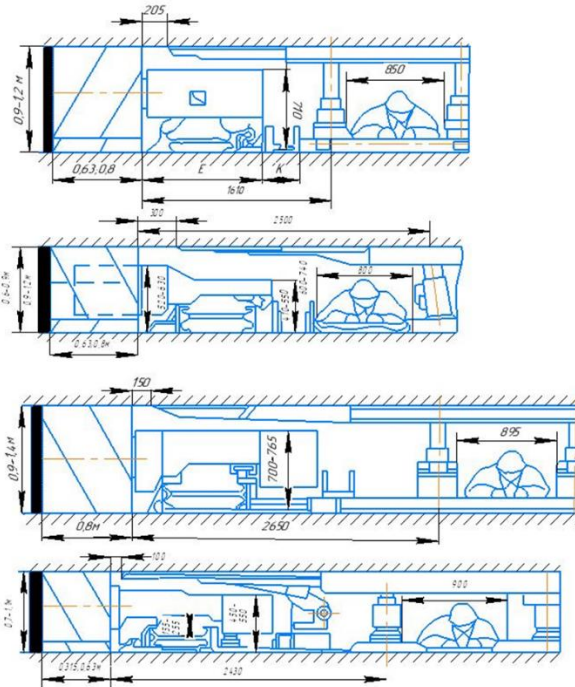

Figure 1.6. Layout diagrams of the cleaning face equipment according to the main layout dimensions

In practice, the adjustment of the size of the Zh is used due to replaceable supports or spacers.

The paper [40] recommends approximate values of the Zh size for various standard sizes that determine the cross-sectional area of the cargo flow on the conveyor, as well as the possibility of passing large pieces of coal without jamming.

Recommended values for Zh are given below:

Standard size	PU8	PU10	PU12	PU16	PU20
The size of the Zh at the main body of the combine, mm:					
with auger (drum)	200	250	350	400	450
with drilling	300	350	400	-	-

The minimum size of the gap B ranges from 90 to 200-250 mm. Smaller values can be realized with reliable stripping of the reservoir soil,

reducing the length of the combined body. The gap B can be increased by reducing the thickness of the overlap when it is made of high-strength materials and reducing the length of its console.

The dimensions E and K generally determine the distance from the face to the first row of support posts, i.e. size 3. The size E depends on the width of the engine housing and the width of the conveyor flight, which, taking into account the width of the conveyor sock, is determined by the maximum productivity of the combine. Reducing the width of the combined body does not always lead to a reduction in the value of E.

The K value is determined by the width of the cable-laying chute, which depends on the number and cross-sections of the laid cables and irrigation hoses.

The value of capture B is stipulated by GOST 11986-73. It should be borne in mind that for combines of small standard sizes, in order to increase their productivity, it is necessary to increase the grip as much as possible. If there are terminal operations in the operation scheme of the machines associated with significant time expenditures in the excavation cycle, as calculations show, it is preferable to increase the grip than the speed of movement of the machine. However, an increase in the grip leads to significant exposure of the roof during coal excavation, which increases the load of the support overlap console, complicates its design, and worsens the nature of roof maintenance.

When designing the magnitude 3, it is desirable to reduce.

The size I between the support console and the face determines the width of the loose bottom hole space, which should be taken as minimal as possible.

The most difficult is the question of choosing a scheme and linking the parameters PU6 and PU8 due to the extremely cramped workspace.

Figure 1.6 shows the variants of the layout schemes of the equipment of complexes for the extraction of coal from thin layers. For scheme I with the arrangement of the 2K101 combine housing above the conveyor, the minimum reservoir capacity where this scheme can be implemented is 0.9 m. Diagram II shows a cross-section of the complex with the K103 combine, designed by Giprouglesh. The combine has a remote feeding system, the combine engines are located parallel to the augers' rotation axes, which made it possible to reduce the length of the combine to 4.5 m. The machine body is displaced into the face. This arrangement made it possible to create a complex of equipment for extracting coal from seams with a thickness of 0.6 m and more. Since the ratio between the diameter of the auger and the height of the conveyor is 3.8-4.4 for small-sized combines (for machines designed to work in medium-sized seams, this ratio is 6-10), it is of great importance to create

conditions for the normal operation of the augers in as loading organisms, since the loading window under these conditions has a limited size. Diagrams III and IV show layout diagrams with K200 and K108 combines.

A distinctive feature of scheme IV is the removal of the combine body towards the blockage. Such a scheme provides good stability for the combine, sufficient height of coal passage under the combine. The shearer provides for an option with a grip size of up to 0.315 m, which significantly reduces the width of the roof outcrop after the miner passes and improves the interaction of the support console with the roof. The support is provided with a console with active support. The layout of the complex allows it to be used in layers with a thickness of 0.7-1 m.

The creation of a domestic K103 shearer with a hull displaced into the face, as well as similar B57 (Great Britain) and EDW170LW (Germany) miners, shows the promise of such schemes for equipment complexes that mine thin seams.

2. MECHANICAL SUPPORTS AND COMPLEXES

2.1 General information

The main means of complex mechanization of coal mining in conditions of long treatment faces at coal mines are equipment complexes and coal mining units with powered supports, in total, as of January 1, 1991, more than 1300 equipment complexes with powered supports were in operation at the coal mines of the CIS, including more than 1000 complexes operating in conditions of shallow (up to 35 °) layers, and 60 complexes in conditions of steep layers.

Of the complexes for shallow layers, the vast majority were used with aggregated supports and only 166 - with complete supports. This ratio reflects a certain tendency towards the predominant development of aggregated powered supports.

The main type of powered supports is a two-post frame section. There is no practice of using four and five-column sections and extremely limited - six-column sections of the fire type.

Complexes with powered supports, depending on their execution, cover the following range of layers in terms of their power (m):

Shield supports	1,8-5,0
Complete supports of supporting type	0,7-1,9
Aggregated supports of the supporting type	0,7-3,5
Aggregated supports with six-column sections of the fire type	0,7-1,2

All complexes work in the faces with roof control by complete collapse.

Due to the increase in the nomenclature of mechanized complexes, their modernization and the creation of new samples, the composition of equipment in them in the presence of the same support may change, therefore, in a complex of the same name with similar powered support, various types of other equipment can be used. The most common composition of equipment complexes is given in Table 2.1.

Table 2.1. Composition of mechanized complexes

Type of complex	Capacity of stratum, m	Type		
		lining (standard size)	dredging machine	face conveyor
КМКДБ	0,7-0,9	Donbass-I	1БКТ, 1К101	МК46У, СП203 СП64П2
КМКДБ	0,85-1,1	Donbass-II	1К101	СП64, СП63М
КСД	0,7-0,9	Donbass-I	УСТ2А, СО75 СН75	УСТ2К, КСО75 КСН75
КМК97	0,7-0,95	МК97 (I)	1БКТ, 1К101	МК46У, СП64
КМК97	0,85-1,2	МК97 (II)	1К101	СП63, СП63М
КМС97	0,7-0,96	МК97 (I)	УСТ2А, СО75	УСТ2К, КСО75
КМ87Э	1,1-1,4	М87Э (I)	1ГШ168, 2К52М	СПМ87Д
КМ87Э	1,3-1,9	М87Э (II)	1ГШ168, 2К52М	СП87П
1МКС	1,1-1,4	1МКС (I)	УСБ67 (УСВ)	СП63Т/С2
1МКС	1,3-1,9	1МКС (II)	УСБ67 (УСВ)	УСВК (КСП75)
КМ87ДН	1,15-1,45	КМ87ДН (I)	1ГШ168	СП87П
КМ87ДН	1,3-1,95	КМ87ДН (II)	1ГШ168	СП87П
КМ87ДГА	1,15-1,45	М87ДН (I)	1ГШ168	СП87П
КМ87ДГА	1,3-1,95	М87ДН (I)	1ГШ168	СПМ87АП
КМ87А	1,5-1,9	М87А	1ГШ168А	СПМ87АП
1МКМ	1,2-1,8	1МКМ	1ГШ168А	СУ1МК
2МКЭ	1,6-2,2	2МКЭ	1ГШ168А	СУ2МКМ
ОКП	1,8-2,5	ОКП1	1ГШ168А	СУОКП
ОКП	2,1-3,0	ОКП	КШМ3М	СУОКП
3ОКП	2,5-3,5	3ОКП	КШМ3М	СУОКП
ОКП70	1,8-2,1 (2,6-3,5)	ОКП70	КШМ3М	СУОКП
КМ81Э	1,8-2,7 (2,0-3,2)	2М81Э	КШ3М	КМ8102БМ
КМ130	2,1-3,8	М130	КШ3М	СП301
КМК120	3,5-4,9	М120	К120	СПМ120К СПЦ261
КТУ2МКЭ	2,8	КТУ2МЭ	КШ3М	СКТ64
АМС	1,9-2,9	КМС	1ГШ168	КМ8102БМ СП202
1АНЦ	0,7-1,8	1АНЦ	Conveyor belt	Conveyor belt
1АЦ	1-2,2	1АЦ	-	-

The powered support of the complex, its design and standard sizes must comply with mining and geological conditions and technical requirements of operation, the efficiency of the rest of the equipment and the complex as a whole depends on it. There are equipment complexes with powered supports of the original design for working in a very diverse mining and geological conditions, as well as extensive experience in their creation, production, and operation.

2.2. Powered supports and complexes for thin layers with an angle up to 35°

The «Donbass» equipment complex is designed for mechanization of cleaning operations on layers with a capacity of 0.7-1.2 m (0.7-0.9 m - I standard size, 0.85-1.2 m - II standard size), with a coal cutting resistance of up to 300 kgf / m, roof rocks of medium stability and stable, soils with resistance to indentation of the support of at least 2 MPa, when controlling the roof with a complete collapse and moving the cleaning face along the strike of the formation (at a drop angle of up to 35 °) and on the uprising (at an angle of incidence up to 10°).

The factors limiting the use of the complex are: geological disturbances within the dredging field that cannot be overcome by the complex; the water content of the face is more than 15 m³/h; the gas content of the formation is more than 15 m³ per 1 ton of daily coal production; degassing that cannot be reduced by existing means; the danger of the coal seam due to sudden emissions of coal and gas.

The «Donbass» equipment complex (Fig. 2.1) consists of powered support of the «Donbass» type 2, a cleaning combine of the BKT type 4 (I standard size of the support) or 1K101 (II standard size of the support), a downhole conveyor of type 3 SP203 (I standard size of the support) or SP63M (II standard size of the support) with a UK1 cable stacker, a SNU5 pumping station, coupling supports 1, hydro and electrical equipment.

The «Donbass» support (Fig. 2.2) is of the supporting type, aggregate consists of separate six-column sections of the fire type with two hydraulic jacks pivotally connected to a conveyor that provides a power connection between the sections of the support. All kinds of misalignments of the support sections relative to the conveyor are eliminated with the help of hydraulic jacks of movement.

The linear section of the «Donbass» support consists of two elements—a bottom-hole 3 and a landing 12, connected to each other in the overlap 8 by a hinge 9, at the base 13 by means of articulated rods 14.

The bottom-hole element of the support section has two hydraulic supports 4 installed between the front base 1 and the upper layers 6. One of these upper layers is equipped with a retractable element, moved by a hydraulic jack 0.8 m towards the face, and the other with a preload element 7, controlled by a hydropatrone 5.

The landing element of the support section consists of four hydraulic supports 18 installed between the rear base 16 and the overlap 10.

To the rear base are attached two hydraulic jacks of the mover 15, located on both sides of the section, which at the end of the mover with the front base enters the space between two rollers located on a beam connected to the conveyor. The cylinders of the hydraulic jacks are connected to the rear base 16, and the rods are connected to the downhole conveyor through- beam 2.

On the side of the worked-out space, there is a fence 11 to prevent the penetration of collapsed rocks from the worked-out space into the bottom hole.

All the hydraulic props of the support section are the same, double hydraulic sliding, double-acting, and the front racks are mounted on stands with a height of 60 mm. In the normal position, the hydraulic props are tilted towards the face by 1-2 °.

On the sides of the support sections, there are skis 17 to ensure their directional movement. For the passage of people, a shelf is laid at the base of the section.

The presence of two hydraulic jacks of movers and side skis on each section ensures the direction of the movement of the support and the retention of the conveyor from sliding along the fall of the formation.

The section is controlled by a hydro block located on the section. The support sections move sequentially one after the other behind the bending section of the conveyor with a 10-15 m lag from the combine outside the zone of intense influence of mountain pressure on the newly exposed roof section. The use of such a scheme for moving the support section allows you to improve the condition of the roof in the face.

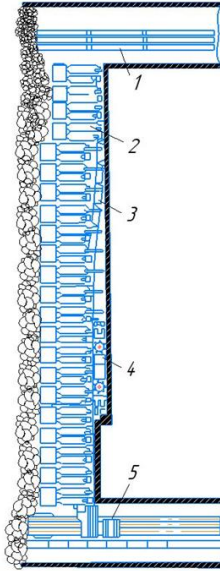

Figure 2.1. Location of the «Donbass» equipment complex in the face

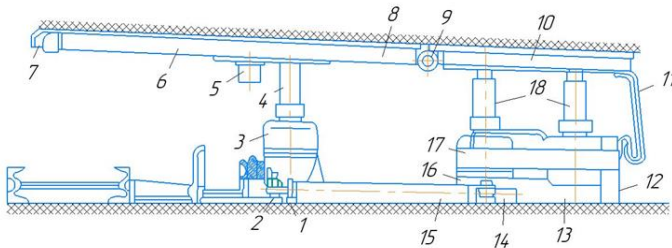

Figure 2.2. Linear section of the «Donbass» support

The SNU5 pumping station, installed on the pumping drift, ensures the operation of the powered support in the face.

Technical characteristics of the «Donbass» complex

Powered support "Donbass"

Operating resistance, tf:

racks	30
landing element	120
bottom-hole element	60
sections	180

Initial thrust, tf:

WAYS OF DEVELOPMENT AND IMPROVEMENT OF POWERED SUPPORTS

racks	19,2
sections	115,2
Working resistance of the support, tf:	
on 1 m^2 of the supporting roofing	38
on 1 m landing row	89
Maximum working fluid pressure, MPa:	
in the pressure line	160
in the piston cavity of the hydraulic prop:	
the first stage of extensibility	250
the second stage of extensibility	600
The installation step of the support sections along	
the length of the face, m	1,35
The course of the hydraulic jack moving sections, m	0,8
The size of the extension of the slide roof beam, m	0,75
Roof tightening coefficient	0,83
Movement force, tf:	
of conveyor flight	9
of support sections	11,3
Average specific pressure, MPa:	
on the roofing	1,0
on the soil	2,0
Main dimensions of the supporting section, mm:	
overlap length	3400
base length	2100
overlap width	1190
minimum height:	
I standard size	500
II standard size	569
maximum height:	
I standard size	960
II standard size	1120
Sliding racks (double hydraulic) mm:	
I standard size	460
II standard size	560
Estimated travel time by 800 mm, s:	
for conveyor	15
for supporting sections	12
Working fluid	Water-oil emulsion
The passage section of the air jet at the minimum width of the bottom hole space, m^2	
on layers with a capacity of 0,7 m	1,56
on layers with a capacity of 1,1 m	2,5

Pumping station SNU5

Productivity, l/min	2×40
Working fluid pressure, MPa	20,0
The mass of the main supporting units, kg:	
double sliding racks	52
hydraulic prop	82,5
hydro block control	66,5
upper overlap	570
grounds	410
assembled sectio	3215
The average metal capacity of the support per 1 m of face, t	1,95
The mass of the equipment of the complex for face with a length of 150 m, t:	
supporting in "Donbass"	360
BKT combine	8,5
» 1K101	9,7
SP203 conveyor	60
« SP63M	68

The complex with the «Donbass» support works according to the shuttle scheme. In the initial position, the conveyor is moved to the face, the combine with the executive body installed in the coal array is located at one of the ends of the face at the drift, the support sections with their bases come close to the bottom-hole conveyor, which ensures the location of the front row of racks at a distance from the face of no more than 1.65 m and improves the conditions for maintaining the roof in the bottom-hole space of the face.

After turning on the drives of the downhole conveyor, pumping station, and combine, the latter takes out a strip of coal to the width of its capture. As the combine passes directly behind its executive body, the sliding elements of the upper layers follow, and the bottom-hole conveyor moves with a bend, and with a lag from the combine at a distance of 10-15 m behind the bending section of the conveyor, the support sections are sequentially unloaded, moved and expanded one by one. At the same time, the retractable elements are pushed into the upper mansions, and the preload elements of the upper mansions are pressed to the roof after moving the sections. Niches are being prepared simultaneously with the extraction of coal, the movement of the conveyor, and the support. The next cycle of work is performed in the same way but in the opposite direction.

The complex of equipment with the «Donbass» support is produced serially by the Druzhkovsky Machine-building Plant.

Equipment complex 1KM103. The 1KM103 mechanized treatment complex was developed and manufactured by Kamensk Machine-Building Plant for the excavation of thin shallow layers by Giprouglemash.

The complex includes: a narrow-reach coal combine 1K103 with a VSP1 feed mechanism; a downhole scraper conveyor SP202B1; a mechanized aggregated support IM103 consisting of four-post sections kinematically connected in sets of two; a cable-laying KC or KCN (at formation angles over 15°); a pumping station SNT32 with a working pressure of 32 MPa; tables from the CO75 planer designed to hold the drive downhole conveyor heads; irrigation system; electrical equipment.

The 1KM103 complex can work on layers with a capacity of 0.7-0.9 m, lying at an angle of up to 35 °, with a length of a cleaning face up to 170 m and a dredging column of at least 600 m. Coal – of any strength, roof rocks - stable and medium stability, soils - with indentation resistance of at least 3.5 MPa, development system - pillar, roof management - complete collapse, gas content of the formation - up to super-high.

Powered support 1 M103 (Fig. 2.3) - aggregated, supporting type, consists of the same type of four-post sections, each of which is connected to the bottom-hole conveyor through a rod and an elastic spring.

The support section consists of the front and rear bases, elastically interconnected by springs. On each base, with the help of other spring shock absorbers, two hydraulic supports are fixed. All hydraulic supports are double hydraulic sliding and in the initial position are slightly inclined towards the face.

The upper overlap of the support section consists of three elements: a console hydraulically raised by a hydropatrone with an elastic part, front and rear overlaps connected by an elastic hinge. The rear part of the overlap through traction has a power kinematic connection with the base.

A box fence is attached to the back of the ceiling, eliminating the possibility of penetration of collapsed pieces of rock into the workspace.

To ensure the directional movement of the support sections relative to each other, each pair of sections is connected to each other by means of a rod that can move along a tubular guide. The support section is equipped with a remote control distributor that provides two-way control of adjacent sections. Each hydraulic rack is equipped with its own rack unit with a gas safety valve GWTN, a discharge valve KGU-3.020 PR and a pressure indicator that is more reliable in operation.

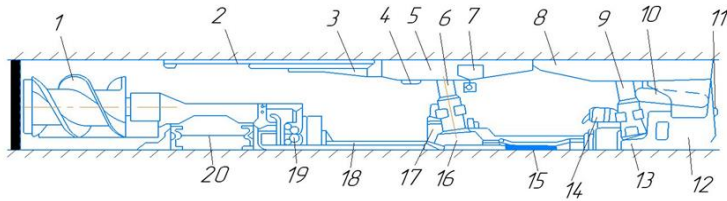

Figure 2.3. Linking the 1M103 powered support section with the 1K103 combine:
 1 - combine 1K103; 2 - elastic spring; 3 - pivotally fixed cantilever part of the overlap; 4 - hydropatrone; 5 and 8 - front and rear parts of the upper overlap; 6 and 9 -hydraulic double hydraulic sliding; 7 - correcting hydraulic jack; 10 - power connection of the base with the overlap; 11 - rear guard; 12 and 16 - rear and front bases; 13 and 17 - shock absorber springs; 14 - distributor for two-way control of the RDU type; 15 - spring connecting element; 18 - traction of the moving jack; 19 - cable-laying machine; 20 - conveyor SP202B

The working pressure in the hydraulic drive system of the powered support (32 MPa) is provided by the CH 32 pumping station with low-speed 2UGNM three-plunger pumps, which have greater reliability in operation.

Technical characteristics of the 1M103 supporting

Section height, mm	500-900
Operating resistance, tf/m^2	50
Section installation step, m	1,2
Movement force, kN	
of supporting sections	195
conveyor ramp	98
Pressure on the soil, MPa	0,35
Formation angle, degree	up to 35
Roofing tightening coefficient	0,85
Section dimensions, mm:	
length	4330
width	1150
height (minimum)	500
Section mass, kg	3250

The minimum features of the 1M103 powered support construction are as follows:

- relatively high operating resistance with low metal consumption of the support section;

- the presence of two convenient passages in the support section for workers moving along the cleaning face;
- work according to the charged scheme and a sufficiently satisfactory plot of the distribution of the resistance of the support along the length of the upper floor, ensuring reliable maintenance of the roof rocks;
- the presence of a power kinematic connection of the upper floor with the base, which allows you to move the sections of the support with active support and exclude the dumping of pieces of roof rocks;
- well-functioning systems of stability and directional movement of the support sections, ensuring reliable, slip-free operation of the support in conditions of inclined layers;
- the presence of a two-way control system for adjacent sections, which creates great operational convenience for workers.

Industrial tests of the first prototype of the 1KM103 treatment complex were carried out at the «Yasinovskaya-Glubokaya» mine of the «Makeyevugol» association along a shallow reservoir with a capacity of 0.7-0.9 m. During the first 320 m of the cleaning face movement, the output power was 0.9-0.83 m, during the next 120 m - 0.75-0.71 m.

The roof rocks of the formation were represented by sand-clay shales with a capacity of 5.2- 5.6 m, soils - sand shale with a capacity of 0.5 - 1 m. The formation had a geological disturbance in the form of discharge with an amplitude of 0.2-1.6 m. The resistance of coal to cutting was 150 kgf/cm. A reservoir with a methane content of up to 5 m³/t. The length of the excavation column is 1000 m, the lava is 200 m.

Installation of the complex at the mine was carried out in 27 days, The complexity of installation and lining 396 people-shifts. Installation costs 34.2 thousand rubles.

The mode of operation in the lava was adopted in four shifts: three mining shifts and one repair and preparatory. During the mining shift, 10 people worked in the lava.

The cycle began with the excavation of coal by lava. The sections of the support moved after the advance of the combine and were combined in time with the excavation of coal. The harvester worked according to the shuttle scheme.

After the end of the excavation of the next strip of coal, self-cutting operations of the combine were carried out using the "oblique arrival" method. The combine was driven into the lava for 10-15 m, the drive head of the conveyor moved. Then the harvester returned, carrying out self-cutting. After that, the frontal movement of the conveyor was carried out. This was the end of the dredging cycle.

The average cycle duration was 81-84 minutes, including operations: driving the combine into the lava by 15-20 m-7, moving the conveyor drive head and bending the flight for self-cutting the combine - 5, self-cutting the combine "oblique arrival" - 7, frontal movement of the conveyor along the entire length of the lava - 17-20, excavation - 45.

For 14 months of work at the Yasinovskaya-Glubokaya mine, the 1KM103 complex produced 256.2 thousand tons of coal with a maximum production of 1,460 tons/day, moving up to 106.6 m/month and worker productivity of 42.9 tons/shift.

The amount of operating time for failure of the 1KM103 complex is 3.4 times greater than that of the «Donbass» complex.

The comparative specific (per 1 hour) labor intensity of inter-repair maintenance (person - hour) of complexes 1KM103 and "Donbass" is given below:

Complex	1KM103	Donbass
The mechanized complex as a whole	4,4	6,5
Including:		
combine	1,0	1,4
face conveyor	1,2	3,0
powered support	2,2	2,1

Thus, a significant increase in reliability in the operation of the 1KM103 complex provided a reduction of about 1.5 times the specific complexity of the overhaul maintenance of the complex equipment.

A particularly important indicator was a decrease in the ash content of the extracted coal by 28% as a result of the excavation of a reservoir with a capacity of 0.7-0.75 m without a hairstyle of side rocks, which gave an absolute reduction in ash content from 24.6 to 17.2%.

According to the «Yasinovskaya-Glubokaya» mine, the annual economic effect of the introduction of the 1KM103 complex amounted to 485 thousand rubles.

Additionally, the possibility of operation of the 1KM103 complex in conditions of inclined formations with angles of occurrence up to 35° was tested during the testing of the second prototype of the complex at the «Miuskaya» mine of the «Torezanthracite» association.

During the test period, the complex produced 177.3 thousand tons of coal, the displacement of the treatment face was 672 m with an average daily load of about 400 and a maximum of 1000 tons. At the same time, it was found that in the conditions of a formation with an angle of occurrence of 28 °, no sliding of the conveyor flight was observed. The work of the

support sections was carried out with active support, which contributed to increasing their stability,

Based on the results of the operation of two samples, the 1KM103 complex was accepted for serial production.

2.3. Powered supports and complexes for shallow layers of medium capacity

MK 75 equipment complex. The MK75 complex includes: powered support MK 75, combine harvester 1GSH68, scraper conveyor BAG 75 with cable laying, supports for coupling lava with drifts, one or two pumping stations SNU5, a typical irrigation system CBT.

A portable double-acting hydraulic jack is supplied with the complex, connected to the distributors of the support sections in the right place, and used for mechanization of installation and dismantling works and equipment repair.

Mining technical conditions for the use of the complex are as follows:

Method of mining	Long pillars along the stretch
Extracting seam thickness, m	1,6-2,2
Angle of incidence of the formation, degree:	
when moving the face along the strike	up to 35
when moving face by falling	up to 18
when working on the uprising	up to 12
Roofing characteristics:	
Direct	Below average stability, but not free-flowing
Main	Any, except difficult to control
Specific pressure on the soil, MPa	0,75
Length of face, m	100; 120; 150
Seizure, m	0,5
Borehole air flow area, m^2	2,8-3,9

The MK75 support is a protective and supporting, aggregated, consisting of sections, each of which is connected to the conveyor by two hydraulic jacks of movement.

The MK75 support differs from the 2MKE support by the following parameters: its scope of application is extended to treatment faces up to 150 m long and layers with an angle of incidence up to 35 °; the specific pressure of the support on the soil of the formation is reduced to 0.65 MPa; the

tightening coefficient of the roof is increased to 0.95; the working resistance of the racks of the support sections is increased to 650 kN, the force developed by the hydraulic jack controlling the hinged console is up to 392 kN; the support sections can be moved with unregulated active support; the pressure of the working fluid in the hydraulic line, it is increased to 20 MPa, in the piston cavities of the racks - up to 32 MPa.

On some of the upper supports of the MK75, there are brackets for connecting two adjacent sections that act as anchors when using the complex to work on formations with angles of incidence greater than 15°.

Technical characteristics of the MK75 support

Support resistance, tf:	
per 1 m ² of supported roofing	40
on the 1st landing row	59
Operating resistance, tf:	
racks	65
sections	130
Pre-strut force, tf/m ²	29
Roofing tightening coefficient	0,95
Step movement of sections, m	0,5
Step installation of section, m	1,1
Movement hydraulic jack force, kN:	
support sections	168
conveyor flight	245
Working fluid	Aqueous emulsion with 1.5 2% additives VNIINP-17
Working fluid pressure, MPa	
in the pressure line	20,0
in the piston cavity of the rack	32,0
Dimensions of the support section, mm:	
height	1350-2200
width:	
by overlap	1028
by base	1010
length	3900-4100
Weight of the support section, t	3,3

The coupling supports for conveyor and ventilation trapezoidal drifts mainly include three sections: anchor, coupling and drift, the anchor four-post section is located in the bottom part of the support and is an anchor to which the other two are pulled. The three-post interface section contacts the main support and supports the drift directly on the interface. The section is connected to the beam of the anchor section by means of a hydraulic jack, a four-post drift section is installed next to the interface section and supports the roof directly on the drift. The drift section of the conveyor drift has a width of 1296 mm, which is necessary for placement on one of the bases of the loader, and the drift section of the support of the ventilation drift is 996 mm.

The drift and anchor sections are connected by two movement jacks. The base of the support of the conveyor drift is pivotally coupled with the guide carriage of the drive head of the conveyor, which thereby has the ability to move relative to the guide while maintaining a constant transfer from the avalanche conveyor to the loader.

In the initial position of the complex, the combine is located at the end of the lava, the conveyor is moved to the face, and the racks of the support sections are located from the conveyor at a distance equal to the step of the support movement. Coal extraction can be carried out both by shuttle and by one-way scheme using the reverse stroke of the combine to sweep the road in front of the conveyor.

During the extraction of coal, the support sections move after the combine. When coal is pressed and the roof is exposed ahead of them, they can be in front of the combine for a full or partial step of movement.

The conveyor to the face moves both along the frontal and along the flank scheme. In the latter case, the movement of the conveyor with the bending of the stave is carried out after the combine carrying out the stripping stroke. With the shuttle scheme of work, it is necessary to have loading shields on the combine or manually clean the coal before the conveyor. When moving the conveyor with the bending of the stave, the total duration of the end operations is reduced.

In the MK75 complex, coal extraction at the end sections of the lava is carried out by a combine and there is no need for preliminary preparation of niches at the ends of the lava.

The OKP70 equipment complex is developed on the basis of the OKP and ZOCC complexes and is designed for mechanization of cleaning operations on shallow formations with an angle of incidence up to 20°, with a capacity of 1.9-3.5 m (1.9-2.6 - I standard size, 2.3-3.5 - II standard size), coal cutting resistance up to 300 kgf/cm, roofs allowing a specific pressure of no more than 0.8 MPa, soils with resistance to indentation of the support

of at least 1.2 MPa, when controlling the mountain pressure by complete collapse. The inflow of water in the lava should not exceed 15 m³/h.

The OKP70 complex (Fig. 2.4) consists of a powered support 2, a cleaning combine 6 of type 1GSH68 (I standard size of the complex), KSHIKG (I and II standard sizes of the complex), KSHZM (II standard size of the complex), a downhole conveyor 4 of type OKP70, powered supports of lava interfaces 3 with a pumping drift 1 and a ventilation drift 5, a pumping station SNU5, hydro and electrical equipment.

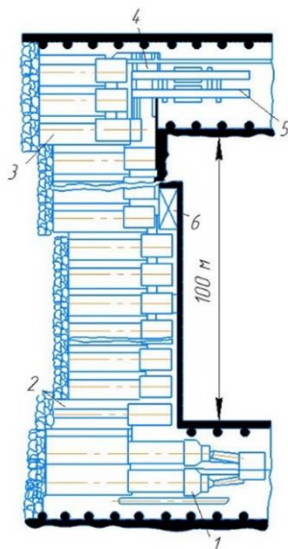

Figure 2.4. The OKP70 complex

The OKP70 complex, in comparison with the OMKTM and OKP complex, has a wider scope of application in terms of reservoir capacity (up to 3.5 m) and angle of incidence (up to 20° with 1GSH68 and KSHZM combines and up to 15° with a KSH1KG combine), freer passage in lava, higher resistance of powered support and other advantages.

The powered support (Fig. 2.5) is of the protective-supporting type, aggregate, consists of separate linear sections, the first 2-terminal 3 sections connected by hydraulic jacks of movement with the conveyor, which is the support base of the complex. The first and end sections of the powered support, as well as the support sections of the interface with the ventilation shaft, are located 0.5 m behind the linear sections to ensure free passage against the drives of the downhole conveyor.

The linear section of the support consists of a base 1, a rack 7 with a hydraulic lock 10, a protective part of the floors 8, a supporting visor 4, traverse 11 and 9, two hydraulic jacks 12, a hydraulic jack 6 for leveling sections with a hydraulic lock 5, a control unit 2 and a block of cut-offs 3.

The base of the box structure is the base for all the equipment of the support section.

Rack - single hydraulic sliding, double-acting Locking of the piston cavity, remote unloading, and pliability of the rack are carried out using a hydraulic lock, in which there is safety and reverse unloading valves.

The protective overlap, designed to protect the bottom-hole space from the penetration of collapsed rocks, has a casing on one side, and a sheet on the other to cover intersectional gaps. The supporting visor is pivotally attached to the upper part of the protective ceiling.

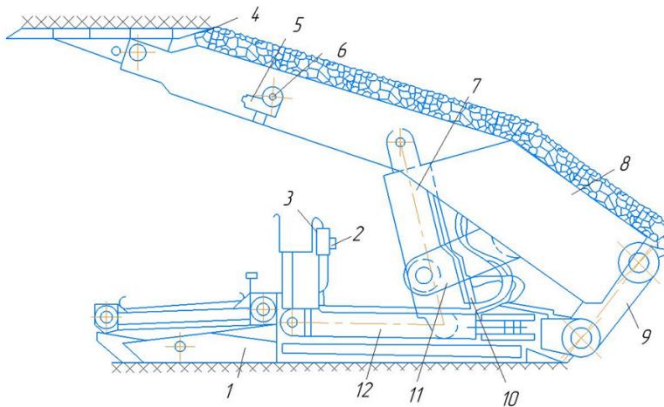

Figure 2.5. The linear section of the OKP 70 complex

The traverses, the base and the overlap form a link mechanism that transmits motor forces from the base to the overlap.

Double-acting hydraulic jacks are designed for moving the support and conveyor.

Alignment jacks with hydraulic locks are installed between the upper parts of the protective floors of adjacent sections and serve to ensure lateral stability of the support sections.

The control unit and the cut-off unit required to control the section are located on the front of the section base.

The first section of the lava support differs from the linear section by the design of the overlap, which has two protective covers and an

additional shield on the visor. The end section differs from the linear section by the design of the visor, which has an additional shield and a support for the thrust rack.

The OKP70 downhole conveyor with a CT4 chain track cable-laying machine has limited flexibility in the horizontal and vertical planes (the rotation angles between adjacent frames are 1 and 4°, respectively). The conveyor is the support base of the complex and consists of the head and end drive units and a grid stave.

The support of the lava interfaces with the pumping (conveyor) drift is developed on the basis of the T6K support and differs from the latter only in the overlap design.

The support for the coupling of lava with the ventilation drift consists of two linear sections of downhole support and two elements (poling board) attached to these sections, consisting of uprights and uprights with support beams.

With the help of the hydraulic drive system in the OKP70 complex, the following operations are performed: unloading, moving, and strutting of the downhole supports, moving the downhole conveyor, controlling hydraulic jacks to straighten sections, moving the coupling supports, etc.

The SNU 5 pumping station is located on one of the drifts and ensures the operation of the support and the complex as a whole.

Technical characteristics of the OKP70 complex

Powered support

Operating resistance:	
racks, tf	180
the supporting part of the support, tf/m ²	54
Initial strut of the rack, tf	75
Maximum working fluid pressure	
in the pressure hydraulic line	200
in the piston cavity of the rack	47; 5
The installation step of the support sections along the length of the face, m	1,1
Roofing tightening coefficient	0,95
The step of moving the support, m	0,63
Movement of the hydraulic jack, m	0,71
Movement force, kN:	
of conveyor	240
of support sections	330

WAYS OF DEVELOPMENT AND IMPROVEMENT OF POWERED SUPPORTS

Average specific pressure, MPa	
on the roofing	0,81
on the soil	1,2
The main dimensions of the section, mm:	
length;	
I standard size	3380
II standard size	3650
Working fluid	Water-oil emulsion
Passage section for the air jet of the bottom-hole space, m ²	
on layers with a capacity of 1.9 m	3,1
on layers with a capacity of 3,5 m	6,4
The mass of the main support units, kg:	
racks:	
II standard size	376
I standard size	483
the supporting visor	
of the fence:	720
I standard size	2247
II standard size	2500
moving hydraulic jack	102,5
hydropatrone	27,0
hydraulic jack alignment	27,5
assembled sections:	
I standard size	4817
II standard size	5335
The average specific metal content of the support per 1 m of face length, t:	
I standard size	4,4
II standard size	4,8
<i>Conveyor</i>	
Productivity, t/min at speed	
movements of the scraper chain, m/s:	
0,93	5
1,16	6,3
Loading height, mm	350
Delivery Length, m	105
Conveyor weight, t	52,5
The mass of the equipment of the complex for face	

with a length of 100 m, t	
powered support	
I standard size	410
II standard size	440
» KSHKG	14-15
combine 1GSH68	12,5-13,5
conveyor OKP70	50,0
combine KSHZM	24,0
pumping station SNU5	2,1

In the lava equipped with the OKP70 complex, two schemes of operation of the combine are provided: shuttle and one-sided, Shuttle scheme is recommended when the angle of incidence of the formation is up to 8 °, one-sided - with a larger angle of incidence.

With the shuttle scheme of operation in the initial position of the complex, the conveyor is moved to the face, the combine is located at one of the ends of the lava with the executive body installed in the coal array, the sections of the downhole support are located at a distance equal to the step of movement from the conveyor. As the coal strip is excavated by the combine, the support sections move sequentially one after another after its executive body, and with a lag from the combine at a distance of 8-12 m, the downhole conveyor. After the coal is excavated, the support and conveyor are moved along the entire length of the lava, the combine is self-chopped and the next cycle is performed in the opposite direction similarly described.

With a one-way operation of the combine, after the coal strip is excavated and the sections of the support are moved, the combine is distilled to the other end of the lava, at the same time the unloaded coal is cleaned, and the conveyor moves in waves behind the combine. After the distillation and self-cutting of the combine, the next cycle of work is performed in the lava with the extraction of coal in the same direction as in the previous cycle.

The OKP 70 complex is mass-produced at the I. I. Fedunets Uzlovsky Machine-Building Plant.

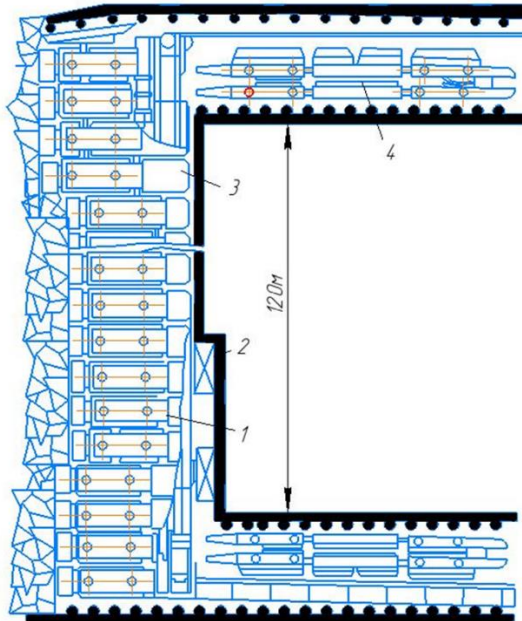

Figure 2.6. Location of the KM130 equipment complex in face

The KM130 equipment complex is designed for mechanization of cleaning operations on layers with a capacity of 2.5-3.5 m, with an angle of incidence up to 35°, easily collapsing roof rocks (I and II classes according to the classification of the former WOOGIE), soils with resistance to indentation of at least 2.48 MPa (version I) and 1.55 MPa (version II) when controlling the roof with a complete collapse. The versions of complex I and II have different values of the resistance of the support.

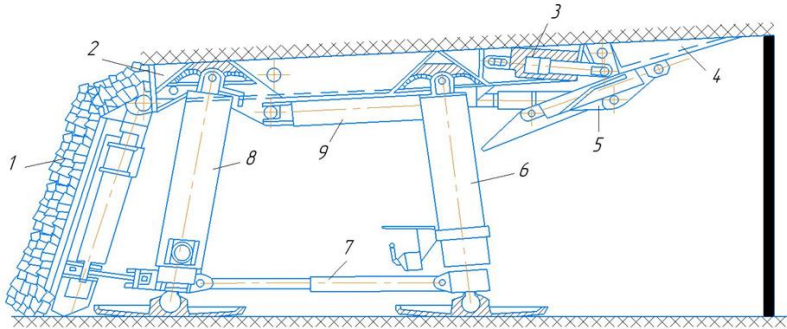

Figure 2.7. Linear support section M130

The KM130 complex (Fig. 2.6) consists of powered support of type 1 M130, a cleaning combine of type 2 KSHZM, a downhole conveyor of type 3 SPM130, a powered support of interfaces of type 4 M81SK, a 1KSP2 loader, a pumping station SNU5 or SNU7, hydro and electrical equipment.

The support M130 is of the supporting type, aggregate, consists of linear and terminal sections of types I and II, depending on the order of their movement.

The linear section of the support (Fig. 2.7) includes an overlap 2 with a visor 4, two hydraulic struts - front 6 and rear 8, a hydraulic jack 9 for moving sections, a hydraulic jack 7 for moving hydraulic struts, a hydropatrone 3, a fence 1, a device 5 for holding coal in the face when it is pressed.

The end sections of the support (8 pcs.) differ from the linear sections by a longer visor, are located at a greater distance from the face (to accommodate the drive heads of the conveyor) and are designed to maintain the interfaces of lava with preparatory workings.

The support sections, except for tongue-and-groove connections in the ceilings, are interconnected in pairs in sets using hydraulic jacks arranged on the cylinders of hydraulic pillars.

The overlap of the section is rigid, a visor controlled by a hydropatrone is pivotally attached to it.

Hydraulic supports of single hydraulic sliding are pivotally connected to the ceiling at the top, and at the bottom - with supports in the form of shoes.

The hydraulic jack is located in the upper part of the section, designed for its movement. The fence at the top is hinged to the ceiling, and at the bottom, it is connected to the lower part of the rear rack.

The device for holding coal in the face, if necessary, is removable, controlled by two hydraulic jacks, pivotally connected to the visor.

The RSHZM cleaning combine is also used as part of other complexes, for example in the OKP complex.

The downhole conveyor SP M 130 is a scraper with a cable-laying machine, a stripping ploughshare on the face side, designed for stripping coal after the passage of the combine, two drive heads, supports for placing the combine.

In addition to the end sections of the downhole support, which are installed on the drifts against the lava, there is M81SK coupling support located on the upper and lower drifts.

The pumping station SNU 5 or SNUG 7 is located on the conveyor drift and ensures the operation of the hydraulic system of the powered support.

Technical characteristics of the KM130 complex

Powered support M130

Operating resistance, tf:	
racks	126; 157
sections	252; 314
Support resistance, tf:	
per 1 m ² of supported area	57; 72
roofing	105; 131
on the 1st landing row	
Initial rasp, tf:	
racks	63; 100
sections	126; 200
Maximum working fluid pressure, MPa:	
in the pressure line	20, 0; 32,0
in the piston cavity of the rack	40, 2; 50,0
The installation step of the support sections along the length of the face, m	1,2
The step of moving the support, m	0,63
Roofing tightening coefficient	0,95
Movement force, kN:	
of conveyor	800
support sections:	
I standard size	125, 6; 128
II standard size	105, 6; 95

WAYS OF DEVELOPMENT AND IMPROVEMENT OF POWERED SUPPORTS

Average specific pressure, MPa:	
on the roofing	0,54
on the soil	1,55; 2, 48
The main dimensions of the section, mm:	
length	3880
width	1440
height	2000-3260
Working fluid	Water-oil emulsion
Passage section for the air jet with a minimum	
width of the bottomhole space, m ² :	
on layers with a capacity of 2.5 m	4,7
3,5 m	8,2
The mass of the main support units, kg:	
racks	453
overlaps	1980
fences	2800
grounds	1450
hydraulic jack for moving sections	155
hydropatrone	65
assembled sections	9400; 9800
Average metal capacity of the support per	
1 m of face length, t:	
without coal retention device	
in the face	3,9
with the device	4,1
The mass of equipment for face with	
a length of 120 m, t:	
powered support M130:	
without coal retention device	
in the face	470
with the device	401
combine KSHZM	24
conveyor SPM130	78

In the initial position of the complex, the conveyor is moved to the face, the executive body of the combine is wound up in an array of coal, sections of powered support are located directly at the conveyor. After the passage of the combine, two adjacent sections of type I support move to the face together with the rear racks, and the front racks tilt towards the face, then type II support section located between the type I sections moves similarly. Behind the combine, the downhole conveyor and the front racks of the moved

sections of types I and II move. After the coal is excavated and the support and conveyor are moved throughout the lava, the work cycle is repeated.

The KM130 complex is manufactured at the I. S. Chernykh Kiselevsky Machine-Building Plant.

2.4. Powered supports and complexes for powerful layers

The complex of equipment 2UKP5. The mechanized complex 2UKP 5 (Fig. 2.8) is designed for excavating coal in lavas with a hard-to-break roof without first softening it. The complex includes: powered support with hydraulic equipment, an avalanche scraper conveyor (it is also the base for moving the support and the combine), a twin-screw combine with a chainless feeding system (UKSH-3, RCU), coupling supports, electrical equipment, a device, and a cable-laying machine.

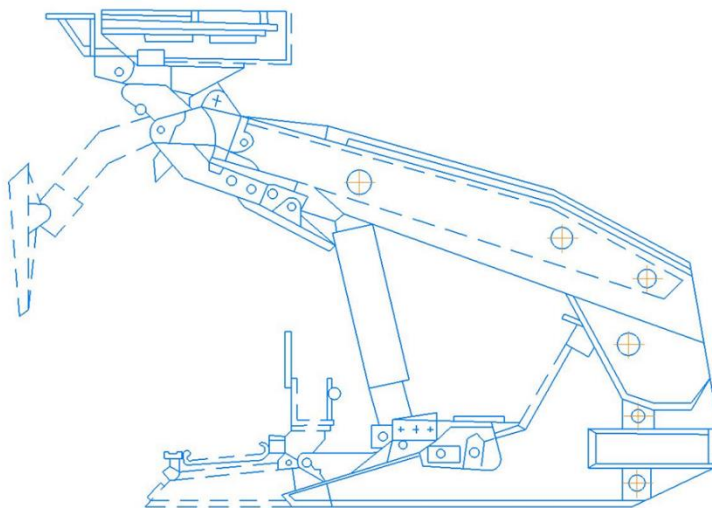

Figure 2.8. Equipment complex 2UKP5

The main mining conditions for the use of the complex are as follows: the removed reservoir capacity of 2.4-4.2 m (4.5 m - with the use of a unified combine); the angle of occurrence when working on a strike up to 35 °, when working on a fall - up to 12 °, the roof - any (including unstable and hard-to-break); the bearing capacity of the soil is not less than 2.0 MPa; the category of the reservoir for gas - any, including super-high.

Technical characteristics of the complex

Type of support	Sectional protective and supporting
The range of extensibility of the support, m	2,25-4,5
The installation step of the support section along the face, m	1,35
Moving step, m	0,5
Bearing capacity of the support sections, MPa	13,0
Working resistance of hydraulic prop, Tf	180
Initial hydraulic prop, tf	76
Movement force, kN:	
Of support sections	64
Of conveyor	220
Roofing tightening coefficient	0,95
Hydraulic system operating pressure, MPa	3,2/20,0

Scraper conveyor

Efficiency, t/h	up to 700
The speed of movement of the scraper chain, m/s	1,3
Loading height, mm	380
Number of electric motors of the type EDKOF-53/4	2
Electric motor power, kW	110

Tests of the prototype of the 2UKP complex with the 2KSHZ combine were carried out at the Raspadskaya mine of the Yuzhkuzbassugol association on a 7-7a formation with a capacity of 3.6-4.2 m in lava 120 m long. The angle of occurrence of the formation is 6-8°, the hypsometry is gently undulating. The formation of a complex structure contained 4-5 layers of siltstone with a capacity of up to 0.3 m. The immediate roof of the formation at a distance of up to 500 m from the mounting chamber was siltstone with a capacity of 7-15 m, prone to collapse by medium-sized blocks. According to the classification of the former WOGIE, the roof belonged to the III class. Further, the immediate and main roof for 600 m was composed of strong sandstone, prone to hanging and large-block collapse,

and also belonged to Class III. Then, at a distance of about 700 m, the roof corresponded to Class II, and the main one was represented by strong sandstone, prone to hanging and collapse in large blocks.

N at a distance of 1110-1150 m from the mounting chamber, a geological disturbance of the thrust type with a vertical amplitude of 1.2-1.5 m was noted, and in the range of 700-760 m, there were washouts 3-5 m wide of the bed part of the formation to a depth of 0.7-1 m. The reservoir capacity in washouts was 2.7-3 m. The soil of the formation is medium-grained siltstone with a capacity of 4-12 m with an indentation resistance of 17.0-20.0 MPa. The depth of development is from 90 to 250 m. The upper layer was worked out with a complex of 1 MKM. A relatively small movement of the upper lava of the formation hindered the work transported by the loader of the 2UKP complex. Coal KSP-2, two belt conveyors 2L-80 and further - on the general mine transport system.

The power supply was carried out from the transformer substations TSSHVP-630 and TSSHVP-400, located respectively on the ventilation and conveyor drifts. Operating voltage 660 V.

On the ventilation shaft, two linear sections of the 2UKP support with transition beams and upper supports of the M81 were used as coupling support. A reinforced T-6K coupling support was installed on the conveyor drift.

Coal production by the 2OKP complex during the testing period amounted to 185.1 thousand tons, the bottom movement was 267 m, the average daily load on lava was 3085 tons.

Compared with the work of the KM130 complex in similar conditions, labor productivity during the work of the 2UKP complex increased by 23%, average daily coal production - by 2.1 times, coal losses decreased by 5%.

Coal extraction was carried out according to a one-sided ledge scheme: when the combine was moving up, a 1-1.8 m high ledge remained at the reservoir soil and a support section moved behind the passage of the combine. During the reverse course of the combine, the remaining coal was extracted with soil stripping and the conveyor moved in sections 8-10 m long. Part of the lava at the conveyor drift with a length of 15 m was processed by a combine at full capacity with its movement along the previously moved conveyor. The notching by the combine was carried out by oblique arrivals without a preliminary niche at the conveyor drift. In this area, the support and conveyor moved immediately behind the passage of the combine. Then both augers of the combine were lifted to the roof, and the operations were repeated.

The results of time-lapse observations showed that the average time factor was 0.64. The speed of the 2KSH-3 combine harvester when moving up averaged 3.8 m/min, varying from 2.1 to 6.1 m/min, and when moving down during lava stripping was 6.1 m/min, varying from 3.5 to 9.95 m/min. The time of movement of one section of the support is 26.8 seconds, the average speed of fastening by one operator is 3.02 m/min, the maximum is 7 m/min (calculated by two operators - 8 m/min).

KM81V and OKP 70V equipment complexes. Mechanized excavation of the lower layer of a powerful shallow reservoir with the release of the upper layer of coal is carried out by the KM81V equipment complex. It was developed at the A. A. Skochinsky IGD together with the Book and the production association "Kargormash" according to the plan of scientific and technical cooperation between the organizations of the former USSR Ministry of Coal Industry and the State Administration of the French Coal Industry. The complex is designed for mining shallow layers (up to 15 °) with a capacity of 4-7.5 m with the release of coal interlayer thickness under a flexible overlap.

The complex consists of KSHZM combine harvester, KM8102B conveyor (SPM81), USTA2A plowing unit, M81V powered support, 2XV coupling support (two sets), KSP2 loader, control equipment, loudspeaker communication and alarm in lava (ACS), irrigation station, hydro and electrical equipment.

The complex is designed for a lava length of 100 m when working out the formation with long columns along with the fall and strike. It is mounted on the soil of the formation. The bottom layer is removed by a narrow-grip combine harvester, under the protection of the support, the under-roof bundle of coal collapses under the action of mountain pressure, is released through the windows under the support, and is unloaded using a plow installation USTA2A.

The complex is used for layers with roofs of class I-III, according to the classification of the former WOOGIE, with the resistance of soil rocks to indentation of at least 1.6 MPa.

Technical characteristics of the M81B support

Section height, mm	
minimum	2210
maximum	3410
Section width, mm	1000
Moving step, mm	630
Operating resistance, tf:	

Of support	45
Of racks	80
Section weight, including jacks, t	4,59

The support sections move behind the passage of the combine, as in the 2M81E support, first type I sections, and type II sections are pulled up to them.

When moving the combine by 10-15 m, the front rack is unloaded and the hydraulic jack connecting the support heels of the racks moves to the face. The KM8102B scraper conveyor (SPM81) also moves to the face of the supporting fifth front rack, after which the hydraulic jack turns on the reduction and moves the front rack to its new location. The rear racks are installed normally to the formation, and the front ones with an inclination of 3-5° are installed in the direction of the developed space.

After the coal strip is excavated by a combine and the supports are moved, the production of the under-roof pack begins.

To improve the release of coal, the fence is raised and lowered by strutting and reducing the support hydraulic jacks. When a rock appears in the "window", the gate is closed and the fence with the gate is tilted with a thrust hydraulic jack, sufficient for the plow installation to work.

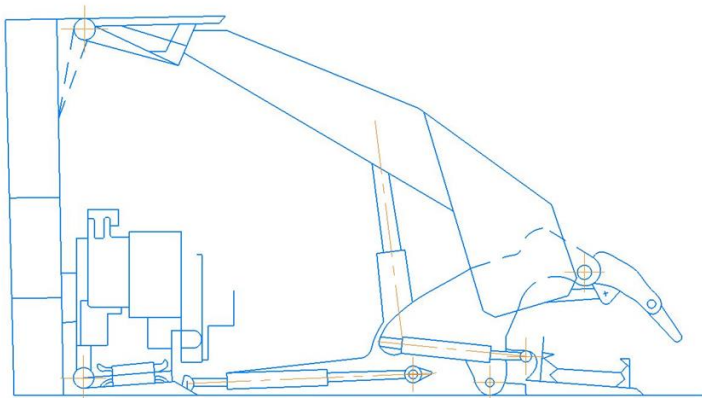

Figure 2.9. Schematic diagram of the complex based on OKP70 support for mechanized coal production of the under-roof thickness

The prototype of the complex passed industrial tests in 1973 at the mine named after Lenin in the Karaganda basin. The complex worked out the D6 formation with a capacity of 4.23-6.46 m with an angle of incidence of 9-

11°. The development system is long pillars by fall, the length of the lava is 95 m. The bottom layer with a capacity of 3 m was removed by a KSH1KG combine. The first tests have not yet allowed us to get high indicators. The load on the complex in the best month was 24.2 thousand tons, with the productivity of the worker at the output of 13.9 tons.

As a result of the tests, it was found that the coal of the underlying layer is heavily clogged with rock, coal losses are large, the issue of coal release from the upper layer is poorly resolved. However, the creation of a new complex based on OKP70 with mechanized production of coal under the roof (Fig. 2.9) on the basis of proven principles will ensure the load on the treatment face of at least 3000 tons/day and the productivity of the worker on the face at the output of 75-80 tons.

The KAM 1C (KAM 2C) equipment complex is designed for the dredging of powerful shallow coal seams with mechanized repayment of the underlying (interlayer) coal thickness by frontally installed plow bodies driven by power hydraulic cylinders.

Mining-geological and mining-technical conditions for the use of the support are as follows: the removed capacity in one layer is 2.8-5.5 m, in two layers 11-12 m; the angle of incidence of the formation is 15-25°; any strength of coal; the presence of rock layers in the coal seam is allowed; the specific load on the soil is not less than 0.75 MPa, the length of the lava is 50-200 m; the length of the excavation column in the fall (strike) is up to 1500-2000 m. The support can be used for the development of coal seams that are dangerous for gas and explosive dust. It is allowed to fluctuate the extracted reservoir power with an amplitude of up to 2 m without disrupting the technological process in the treatment face. With a reservoir capacity of up to 5.5 m, a system of development with falling bands at full capacity is recommended, and at 7 m or more, with falling bands (stretching) with a minimum number of layers.

The use of the KAM complex in lavas with weak or prone to heaving soil with significant mining and geological formation disturbances and water inflow is possible when developing special measures.

The complex of equipment KAM 1C (KAM 2C) consists of a powered support KAM 1C (KAM 2C), a narrow-grip combine KSHZM (other narrow-grip combines can be used), a scraper bending conveyor SPM81, a PKTU loader, a pumping station SNU6, electrical and other auxiliary equipment.

With the help of the hydraulic support system, the following operations are performed: movement of the downhole conveyor, unloading, and strutting of the support section, unloading, feeding to the face and strutting of rigid guide frames, as well as planning of the upper thickness with

a planed cutter head. In addition, the section is controlled in the horizontal and vertical planes. The control of the support in the horizontal plane is carried out with the help of hydraulic jacks of movement, and in the vertical - with the help of executive bodies and racks of the support section.

From the pumping station located on the drift, main pipelines run along the length of the lava, which is suspended from the floors or laid in the blockage of the lower shield of the support section. The control of the racks and hydraulic jacks is individual, with the help of special hydraulic valves fixed on the ceilings of the support sections.

The downhole conveyor JV M 81 has a reinforced structure adapted for the stable operation of heavy coal combines, guided by special grippers along the sides of the conveyor stave. The conveyor on the face side is equipped with a stripping plowshare, and on the side of the worked-out space - a gutter for the cable-laying machine. The height of loading coal on the conveyor is 245 mm.

The pumping group of the KAM complex is equipped with three or four SNU 6 stations, each of which is an aggregate with two pumps, a tank, and a system for monitoring normal operation.

Technical characteristics of the KAM type complex

Linear support section

Type	Protective-supporting, single-section, double-column
Structural height, mm:	
Minimum	2700
Maximum	3250
Distance between the axes of the racks, mm:	
Of one section	1000
Of adjacent sections	300-400
Width, mm	1400
The step of moving the section,	0,63
Bearing capacity of the rack, tf	up to 80
Working pressure in the hydraulic line, MPa	15-20
Maximum rack pressure, MPa	40
The jack force of the section movement,	

WAYS OF DEVELOPMENT AND IMPROVEMENT OF POWERED SUPPORTS

kN	200-400
The force of the power hydraulic jack of the working body, kN	up to 400
Bearing capacity of the hydraulic jack for extending and maintaining guides, tf	up to 90
The angle of incidence of the formation, degree	up to 15
Working fluid in the hydraulic line	1.5% of emulsion
Number of sections (for a face length of 50 m)	33
Method of moving sections	hydraulic
Weight of the support, t	270

Hydraulic system

Number of telescopic active executive bodies (for a face length of 50 m)	28
Cylinder stroke for lifting the shield, mm	700
The force of the paired cylinder for lifting the organ, kN	1500
Stroke of the lifting cylinder of the guide organs, mm	800
Effort, kN:	
shield lifting cylinders	800
the paired cylinder of the plow cutter head	400
cylinder extension and expansion of the guiding body	600
Number of hydraulic cylinders of the control body	28
Stroke of the hydraulic cylinder rod of the control organ, mm	500
Number of hydraulic jacks of movement	33
Movement hydraulic jack rod stroke, mm	750
Effort, kN:	
Of piston cavity	400
Of rod cavity	275

The powered support KOM 1C (KAM 2 C) has frontal executive bodies of 28 linear and five end sections, which are connected to the movement beam with the help of hydraulic jacks.

A special tray made of the conveyor belt is installed in each section to direct the chipped coal produced from the under-roof layer. End shields are provided on the end sections, designed to prevent rock and coal from entering the support section from the side of the safety pillars. The support movement beam consists of eight elements and seven transitional connecting links. Eight special eyelets for jacks and support sections are welded to each element of the beam. The connecting transition links of the section movement beam provide the necessary flexibility in the horizontal and vertical directions.

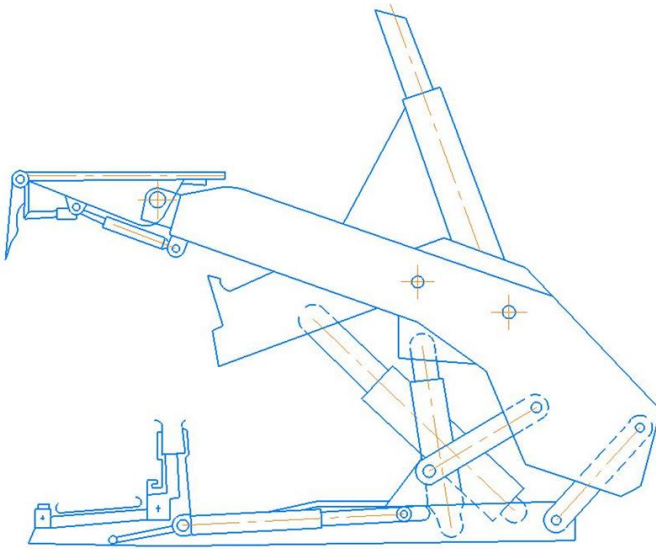

Figure 2.10. Schematic diagram of the section of active powered support KAM2C

Coal in the lava is removed by a KSHZM combine with a screw width of 0.63 m. In the initial position, the combine is located in the lower niche, and the conveyor and the support sections are moved to the chest of the face. The plowing organs of the section are in the extreme forward position, and the incisor heads overlap the angle openings, thereby excluding the fall of large pieces of coal from the under-roof thickness into the bottom-hole space. The linear section of the upgraded complex with the active support of the KAM type is shown in Fig. 2.10.

3. BASICS OF CALCULATING POWERED POWER SUPPORTS

3.1. Determination Of Loads On The Elements Of Powered Supports

Based on the operational and technical requirements, modern powered supports should provide reliable protection of the working space of the treatment face from the penetration of lateral rocks into it and safe working conditions in lavas, roof management, methods of complete collapse or smooth lowering and movement following the movement of the treatment face. The support must be controlled in the plane of the formation and in a plane perpendicular to its occurrence and providing directional movement of its section following the movement of the face.

Resistivity of supporting type supports (average) q is taken depending on the thickness of the layers within: $m \ll 1$ m, $q \gg 200$ kN/m³; $m=1-2$ m, $q \gg 300$ kN/m²; $m > 2$ m, $q \gg 400$ kN/m². The resistivity of the supporting parts (average) of the protective-supporting type supports in relation to conditions with easily collapsible roofs, weak coals and shallow occurrence from the surface - 200 kN/m².

The height and extensibility of the support struts must correspond to the reservoir capacity and are accepted depending on the actual values of power fluctuations within the excavation column. In addition, when choosing the minimum and maximum size of the support in height, the amount of lowering of the roof and the margin of compliance of the support for unloading are taken into account.

The dimensions (width and height) of the free passage of people between the protruding parts of the equipment should be at least 0.7×1.5 m. The support should pick up the roof when coal is excavated, preventing prolonged exposures of the roof strip along the face of the entire lava with a width of more than 0.3 m (with an exposure of more than 1 hour) and short-term exposures (less than 10 minutes) for shallow layers from 0.8 to 1 m of sections more than 8 m² and for layers 1-2 m of roof sections more than 10 m².

The forces transmitted by the front ceiling consoles to the roof should be at least 15-20 kN. When the length of the overlap console is more than 1 m, its end is active, i.e. having freedom of deviation relative to the rest of the overlap up and down at an angle of at least $\pm 10^\circ$.

The distance from the face to the front row of the support posts does not exceed 1.5 m, and the initial spacer is 40-50% of the working resistance. The movement of the supporting parts of the support, especially with a

weakly resistant roof, must be carried out with residual support of up to 20 kN/m^2

Loads on the supporting and protective elements of the supports.

It is established that the pressure on the supporting parts of the supports is distributed unevenly and increases from the face to the blockage according to a law close to trapezoidal, with a ratio of bases up to 1: 10 or more.

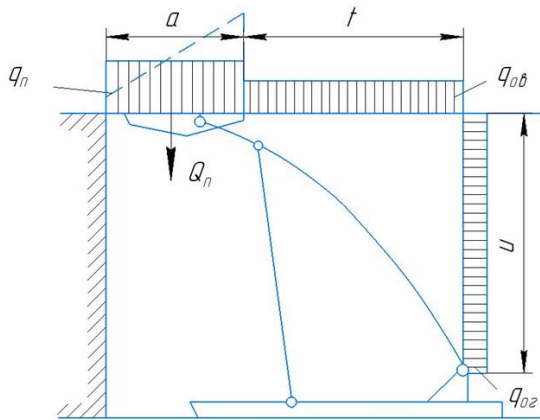

Figure 3.1. Loads on the supporting and protective elements of the protective and supporting supports

With single-support supporting parts, rock pressures are conditionally set evenly distributed over the area of the supported roof (Fig. 3.1), and with two or more supporting ones distributed over the width of the supporting strip according to the trapezoidal law (Fig. 3.2) with bases of $q_{1p}=30 \text{ kN/m}^2$ at the bottom of the face and $q_{2p}=370 \text{ kN/m}^2$ at the blockage end.

The rock pressure on the protective parts is set as a uniformly distributed component vertically $q_{o.v}=150 \text{ kN/m}^2$ and horizontally $q_{o.r}=80 \text{ kN/m}^2$.

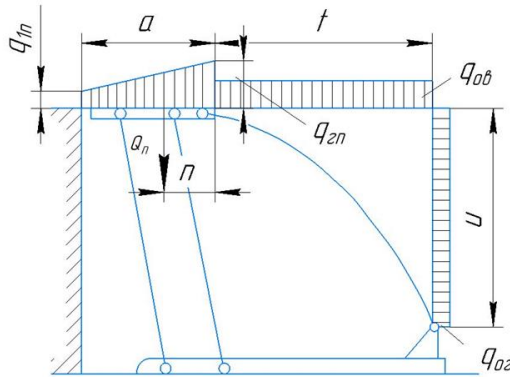

Figure 3.2. Loads on the supporting and protective elements of two or more supporting protective and supporting supports

supporting protective and supporting supports

The total load on the supporting elements will be determined for single-support supports:

$$Q_P = q_{s.res} a \cdot b, \quad (3.1)$$

where $Q_{s.res}$ – is the specific resistance of support (equal to 200 kN/m²); a - width of the supported roof strip, m; b - installation step, m.

For multi-support supports:

$$Q_P = \frac{q_{1P} - q_{2P}}{2} ab. \quad (3.2)$$

The distance of the point of application of the force from the rear end of the supporting part is:

$$h = \frac{q_{2P} - 2q_{1P}}{3(q_{1P} + q_{2P})} a. \quad (3.3)$$

The total vertical and horizontal forces on the protective part are determined depending on its configuration. With protective parts outlined in a circle:

$$Q_{o.v} = q_{o.v} \cdot t \cdot b; \quad (3.4)$$

$$Q_{o.v} = q_{o.v} \cdot U \cdot b, \quad (3.5)$$

where t and U are vertical and horizontal projections of the protective part. The

Total pressure is:

$$N_o = \sqrt{Q_{o.v}^2 + Q_{o.g}^2} \quad (3.6)$$

The resulting force passes through the midpoint of the chord and perpendicular to it (see Fig. 3.2). With fencing elements with a complex configuration, the fence is conventionally divided into sections, provided that the ratio of the chord length and segment height is not less than 20 (Fig. 3.3). If the angle of inclination is less than 20° , the load in this section is assumed to be distributed along a trapezoid with bases: $q'_{1o.v}=370 \text{ kN/m}^2$. $q''_{1o.v}=200 \text{ kN/m}^2$

The vertical and horizontal components of the loads acting on a section with a rectilinear diagram are calculated using the formulas:

$$Q_{i.o.v} = q_{o.v} \cdot t_1 \cdot b; \quad (3.7)$$

$$Q_{i.o.g} = q_{o.g} \cdot U_1 \cdot b, \quad (3.8)$$

where t_i and U_i - are the horizontal and vertical projections of the i -th section, m.

The resultant horizontal and vertical components corresponding to uniform pressure curves are determined as follows:

$$N_i = \sqrt{Q_{i.o.v}^2 + Q_{i.o.g}^2} \quad (3.9)$$

For areas with corners of $< 20^\circ$ the normal forces will be:

$$N_{ig} = Q_{i.o.v} \cdot \cos \alpha_i; \quad (3.10)$$

$$N_{iv} = Q_{i.o.g} \cdot \sin \alpha_i. \quad (3.11)$$

The resultant loads on the protective part is found by constructing a polygon of forces, and the line of its action - by constructing a rope polygon (see Fig. 3.3)

Determination of the working resistance of hydraulic supports.

The working resistance of the support is calculated taking into account the loads from the pressure of the rocks N_p and N_o , the own weight of the support G , the friction forces and the contact of the supporting and protective elements with the lateral rocks and the forces acting on the protruding elements of the foundation of the support N' .

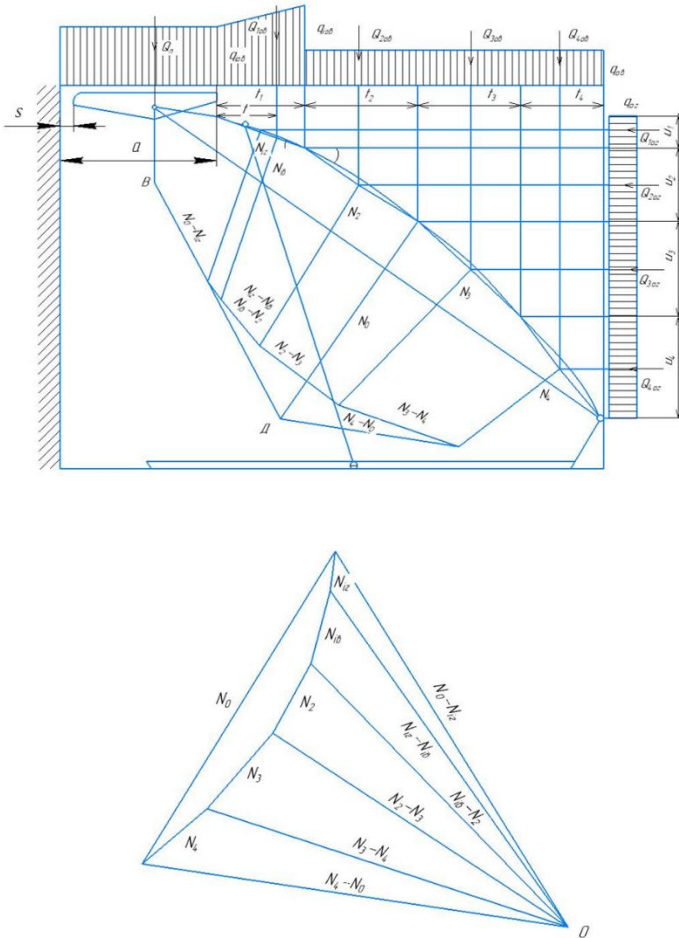

Figure 3.3. Loads on protective elements with a complex configuration

The direction of action of the friction forces is chosen opposite to that at which the section can overturn due to the absence of friction forces. To do this, constructing a polygon of forces and a rope polygon, we find the resultant forces N_P , N , N' , G , D acting on the section, disregarding the friction forces (Fig. 3.4):

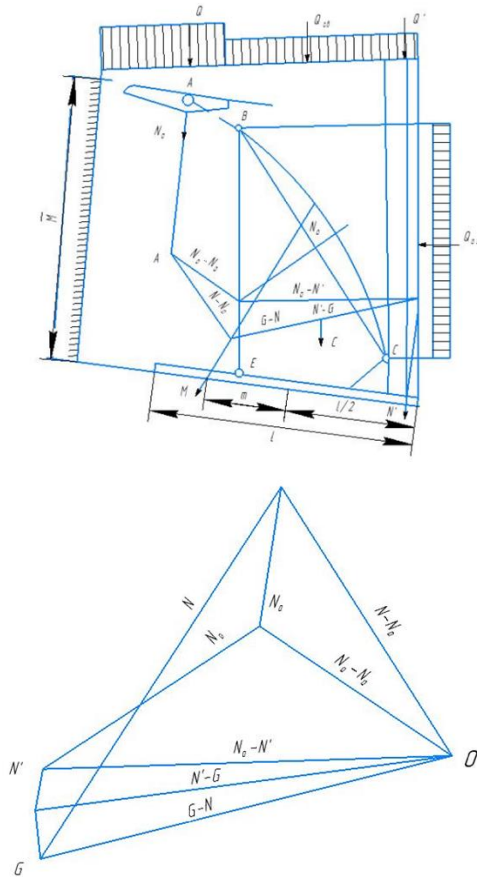

Figure. 3.4. Determination of point M and the intersection of the resultant force with the base of the support

If point M lies to the left of the middle of the reference length of the base (point D), then the section tends to overturn counterclockwise. The

direction of the friction forces for this case should be chosen so as to prevent overturning.

The acting forces of friction are equal:

$$F = f \cdot N_t. \quad (3.12)$$

To determine the calculated values of the coefficients of friction at rest, calculate the overturning moment of active forces M_{ak} and relative to the middle of the reference length of the base of the friction forces M_{tr} (Figure 3.5):

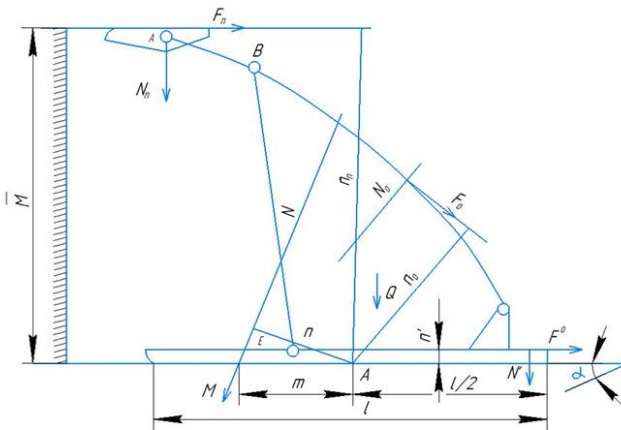

Figure. 3.5. Determination of the moment of overturning forces acting on the section

$$M_{ak} = N \cdot h; \quad (3.13)$$

$$M_{tr} = F_p \cdot h_p + F_0 h_0 + F' \cdot h' \quad (3.14)$$

and:

$$M_{tr} = f(N_p \cdot h_p + N_0 h_0 + N' \cdot h'). \quad (3.15)$$

Equating the right-hand sides of (3.13) and (3.14), we obtain:

$$f = \frac{Nh}{N_p h_p + N_0 h_0 + N' h'}. \quad (3.16)$$

The coefficient of friction of the metal on the rock (f_0) is taken equal to 0.40. If it turns out that $f < f_0$, then the friction forces are calculated by

the coefficient of friction f . For $f > f_0$, the calculation is carried out according to $f_0 = 0.40$. The supports perceive the pressure of the lateral rocks acting on the supporting and protective elements, the resultant of which is the geometric sum of the forces P_p and P_o . On the supporting and protective parts of the support. In turn, the forces P_p and P_o are the resultant of normal forces and friction forces (Fig. 3.6). The point O of the intersection of the resultant with the axis ALL of the hydraulic prop determines the line of action of the reaction in the hinge R_{SH} .

By decomposing the force R, the reactions of the hydraulic props R_C and R_{SH} of the hinge are found.

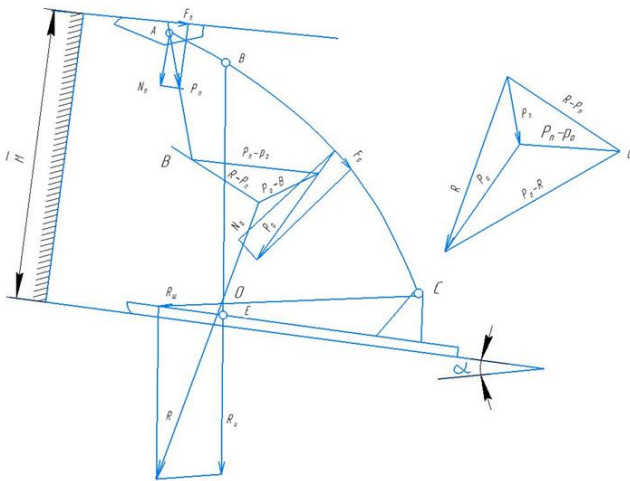

Figure. 3.6. Determination of the forces acting on the rack and in the hinge of the rack when the protective part rests on one hinge

For supports of a protective-supporting type, when the fence rests not on one hinge, but on two levers, an equation of moments from the forces R and R_c relative to the point O obtained by the intersection of the lines of action of the forces C and D (Fig. 3.7) is compiled.

From the equation of moments it is determined:

$$R_c = \frac{Rh_1}{h_2}, \quad (3.17)$$

Further, from the polygon of forces, C and D. are found.

Establishing the parameters of the load-bearing elements of the lining section of the protective-supporting type when moving with residual backwater. In contrast to the existing shielding-type supports, the spacing of the protective-supporting supports is made by yielding racks. This allows you to adjust the height of the support section depending on the removed layer thickness.

During the operation of such supports on the lower layers, deformation of the coal pack is possible. To prevent coal from falling out at the bottom of the face during movement and to ensure the stability of the section, a sprung canopy must be provided in the structure.

In order to select the parameters of the power elements of a section of this design, we will consider the process of its movement with the residual space of the struts.

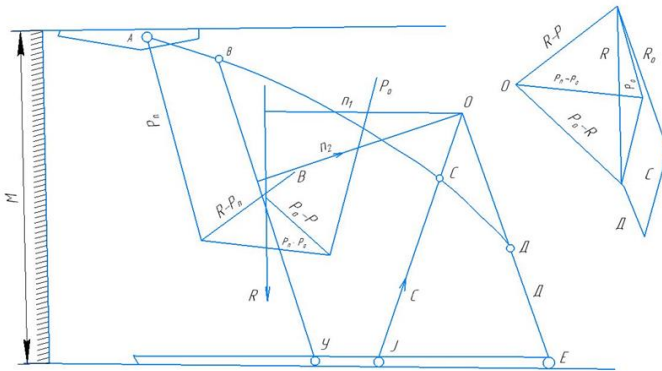

Figure 3.7. Determination of the forces acting on the rack and in the levers when supported two levers

The differential equations of motion of the sections (Fig. 3.8) are as follows:

$$M_c \frac{d^2 X_c}{dt^2} = P_A - (T_v + T) - P_c \sin \alpha_1; \quad (3.18)$$

$$M_c \frac{d^2 Y_c}{dt^2} = P_c \cos \alpha_1 - N + H_1; \quad (3.19)$$

$$I_c = \frac{d\omega}{dt} = -P_A \cdot d - T_v \cdot a_6 + T \cdot b + N \cdot e + H_1 k, \quad (3.20)$$

where H_1 is the resistance force of the roof canopies, kN/m^2 ; P_c is the section weight, kN ; P_A - effort of movement, kN ; T_v - friction force of the canopy on the roof, kN ; T is the friction force of the base on the soil, kN ; M_c - section weight, kg ; α_1 - formation dip angle, deg ; N is the reaction of the soil, kN ; f is the coefficient of friction of steel on coal; I_c - moment of inertia of the section relative to the axis passing through the center of gravity and perpendicular to the xoy plane, m ; C is the center of gravity of the section.

We assume that the section moves in a straight line. The axis passes through the center of gravity of the section, therefore, from the combat equation (3.19) we have:

$$N = H_1 + P_c \cos \alpha_1 \quad (3.21)$$

From equation (3.18) we obtain:

$$\begin{aligned} \frac{d^2 X_c}{dt^2} &= \frac{1}{M_c} [P_A - (T_v + T) - P_c \sin \alpha_1]; \\ \frac{dX_c}{dt} &= \frac{t}{M_c} [P_A + P_c \sin \alpha_1 - (T_v + T)] + C_c; \end{aligned}$$

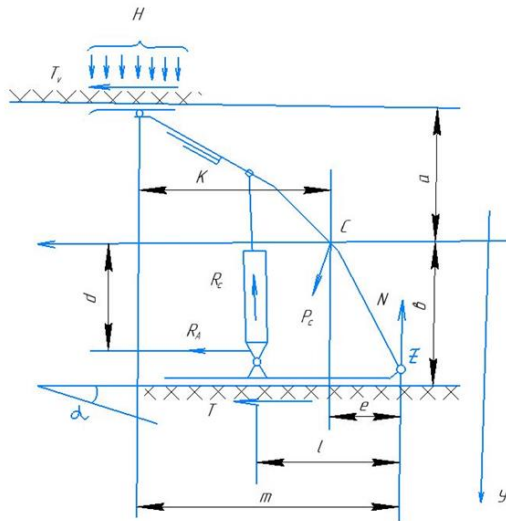

Figure 3.8. Design scheme for determining the forces of movement of the sections depending on loading bridges

It is known that for $t=0$ $V_p^c=0$, therefore, $C_1=0$:

$$X_c = \frac{t}{2M_c} [P_A + P_c \sin \alpha_1 - (T_v + T)] + C_2;$$

at $t=0$ $X_c=0$, therefore $C_2=0$. Then:

$$X_c = \frac{t^2}{2M_c} [P_A + P_c \sin \alpha_1 - (T_v + T)]; \quad (3.22)$$

$$X_c = \frac{gt^2}{2P_c} [P_A - (T + T_v - P_c \sin \alpha_1)].$$

At $\alpha_1 = 0$:

$$X_c = \frac{gt^2}{2P_c} [P_A - (T_v + T)];$$

At $\alpha_1 < 0$:

$$X_c = \frac{gt^2}{2P_c} [P_A - (T_v + T) + P_c \sin \alpha_1].$$

From equation (3.20) we have:

$$\frac{d\omega}{dt} = \frac{1}{I_c} (-P_A \cdot d - T_v a + T \cdot b + Ne + H_1 k);$$

$$\omega = \frac{t}{I_c} (Tb + Ne + H_1 k - P_A d - T_v a) + C_3;$$

At $t=0$ $\omega_0=0$, therefore, $C_3=0$.

Also, $\omega=0$, since the movement is linear.

Finally:

$$Tb + Ne + H_1 k - T_v a = P_A d.$$

From here:

$$P_A = \frac{T \cdot b + N \cdot e + H_1 \cdot k - T_v \cdot a}{d} \quad (3.23)$$

To establish the place of application of the soil reaction, we compose the equation of moments with respect to the point O:

$$\sum M_z = P_c e + H_1(k + e) - T_v(a + d) + T(b - d); \quad (3.24)$$

and considering that:

$$T_v = H_1 \cdot f; \quad T = (H_1 + P_c)f \quad (3.25)$$

We have:

$$e = \frac{H_1 \cdot f(a + d) - (H_1 + P_c) \cdot f \cdot (b - d) - H_1 k}{P_c + H_1}$$

Substituting the values of the arms and taking $f = 0.3$, we find $H = 147$ kN, $e = -0.84$ m. Then:

$$P_A = \frac{(H_1 + P_c)fb - (H_1 + P_c \cos \alpha_1)e + H_1 k + Hfa}{d} \quad (3.26)$$

Formula (3.26) shows that the force of movement P_A increases with an increase in the loading and weight of the section and decreases with an increase in the angle of incidence of the formation α_1 .

3.2. Calculation for strength of elements powered supports

Schemes of interaction of floors and fences with roof rocks. The basis for calculating the strength of powered roof supports is the knowledge of the nature of the interaction of the ceiling with the roof rocks. The conditions of this interaction depend both on the design and parameters of the overlap, and on the mining and geological conditions that determine the properties of the side rocks, as well as mining factors. The variety of factors affecting the loading of the roof supports significantly complicates the choice of a reasonable nature of the load over the floor area. Contact with the rocks of the roof can occur both over the entire surface of the overlap, and on individual sites, therefore, to obtain the actual nature of the loading of the overlaps in specific conditions, special studies should be carried out with the processing of their results by a probabilistic-statistical method. However, for the sake of simplicity, in engineering calculations, we conventionally assume that the floors are in contact with the roof rocks at separate sites (points), which create the most unfavorable conditions for loading the floor.

Overlapping supports of the supporting type. In the design scheme of a rigid solid overlap (Fig. 3.9, 3.10) with a two-point variant of contacting the overlap with the roof (Fig. 3.10, a), the displacement of the contact points from the edges of the overlap is taken equal to $a_1 = 0,2l_1$; $a_2 = 0,2l_2$, but not less than 5 cm. The total displacement of the points of contact from the longitudinal axis of the overlap:

$$m_1 + m_2 = 0,3b. \quad (3.27)$$

In the case of a one-point contacting option (Fig. 3.10, b), the point of contact between the floor and the roof is located on the axis of the floor, in the middle of the span between the uprights. To determine the force acting on the floor at the points of contact with the roof, static equilibrium equations are drawn up:

$$\sum M_B = R_k(l_k + L - a_2) + R_1(L - a_1 - a_2) + P[l + 2(l_2 - a_2)] = 0; \quad (3.28)$$

$$\sum Y = 2P - R_k - R_1 - R_2 = 0; \quad (3.29)$$

$$\sum M_d = R_1m_1 - R_2m_2 = 0; \quad (3.30)$$

The same is done when calculating loads on a supporting floor of other types, for example, for a rigid floor with a double-hinged connection, the scheme of interaction of which with the roof is shown in Fig. 3.11, and the design scheme is shown in Fig. 3.12. When calculating such an overlap, it is divided into its constituent elements: a beam, a bottomhole and a gravel base part of the overlap (Fig. 3.13-3.15). In the design diagram, the beams are supported by hinges A and B.

To determine the reactions R_A and R_B , we compose a system of static equilibrium equations:

$$\begin{aligned} \sum M_B &= R_A(l_A + l_V) - P_1l_V = 0; \\ \sum Y &= P_1 - R_A = R_B = 0. \end{aligned} \quad (3.31)$$

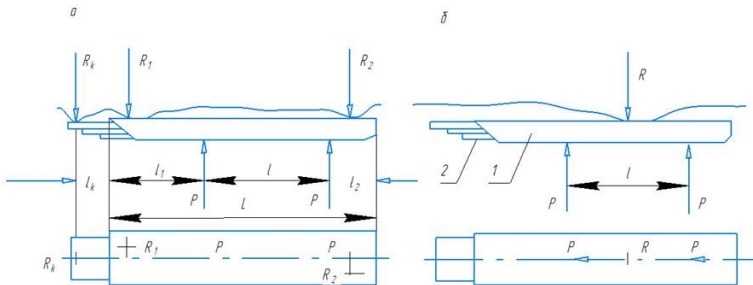

Figure 3.9. The scheme of interaction with the roof of a rigid solid floor: 1-the base part; 2-the flexible console

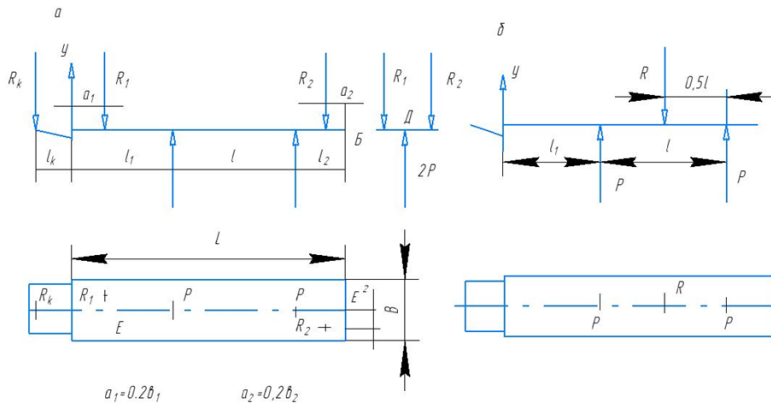

Figure 3.10. Design scheme of a rigid solid floor with a flexible console

The displacements of the points of contact from the edges of the overlap in the design scheme of the bottom hole (see Fig. 3.14) are taken equal to

$$a_1 = 0,2l_1; \quad a_2 = 0,2l_2; \quad b_2 = 0,2B_1.$$

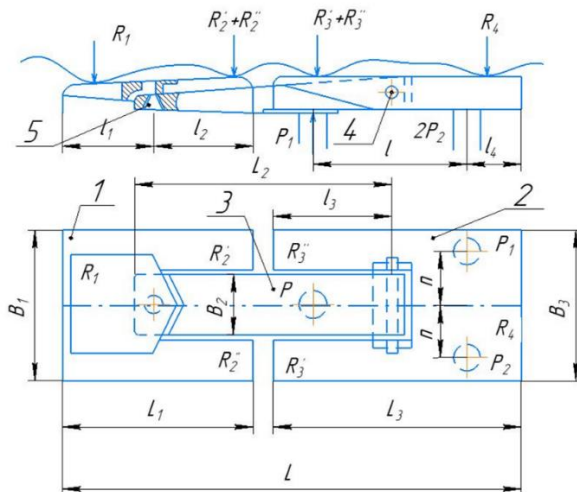

Figure 3.11. Scheme of interaction with the roof of a rigid floor with a double-hinged communication:

- 1 - bottom hole base part; 2 - entryway base part; 3 - basic part (beam);
- 4 - horizontal hinge; 5 - vertical hinge (spherical)

The b_2 value should be no more than the width of the projections of the cantilever parts B1.

To determine R_1, R'_2, R''_2 and the value of m_1 , we compose a system of equations of static equilibrium

$$\sum M_D = R_1(L_1 - a_1 - a_2) - R_A(l_2 - a_2) = 0;$$

$$\sum M_D = R_1 m_1 + (R'_2 + R''_2)(0,5B_1 - B_2) = 0;$$

$$\sum Y = R_A - R_1 - R'_2 - R''_2 = 0.$$

$$R''_2 = 1,3R'_2.$$

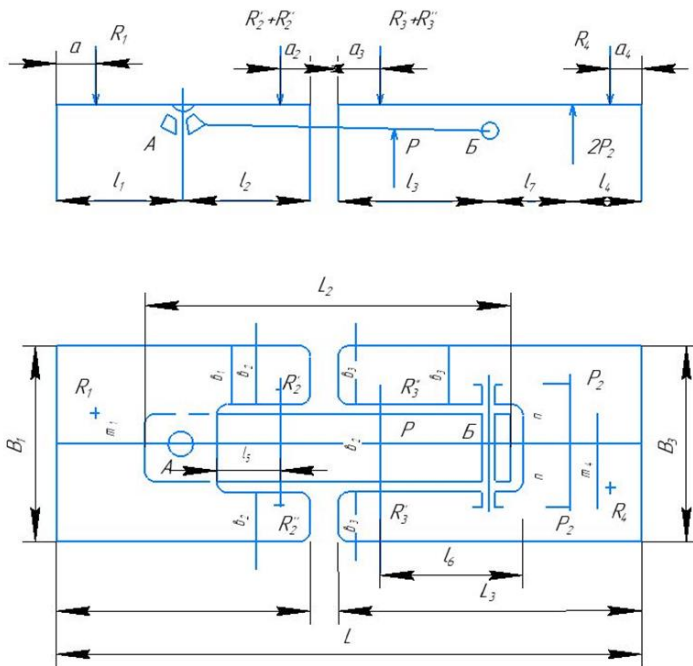

Figure 3.12. Calculation scheme of a rigid overlap with a double-hinged connection

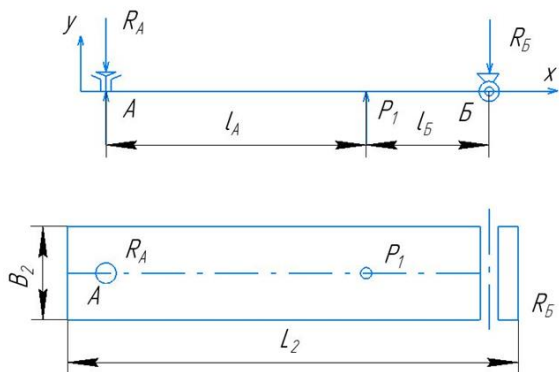

Figure 3.13. Design model of a rigid floor beam with a double-hinged connection

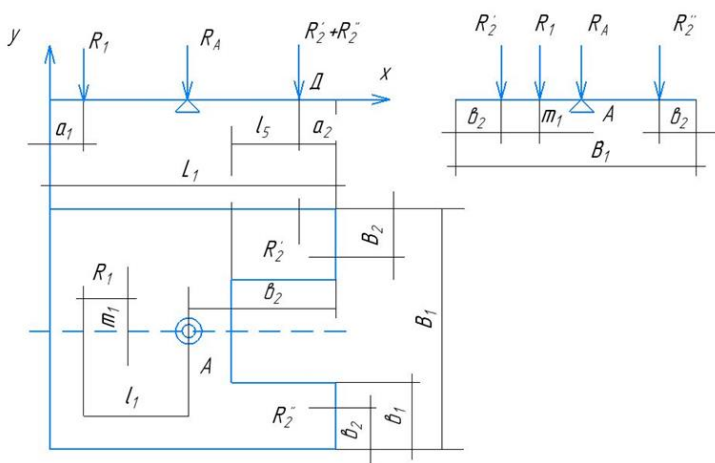

Figure 3.14. The design scheme of the bottom-hole base part of the overlap part with a double-hinged connection

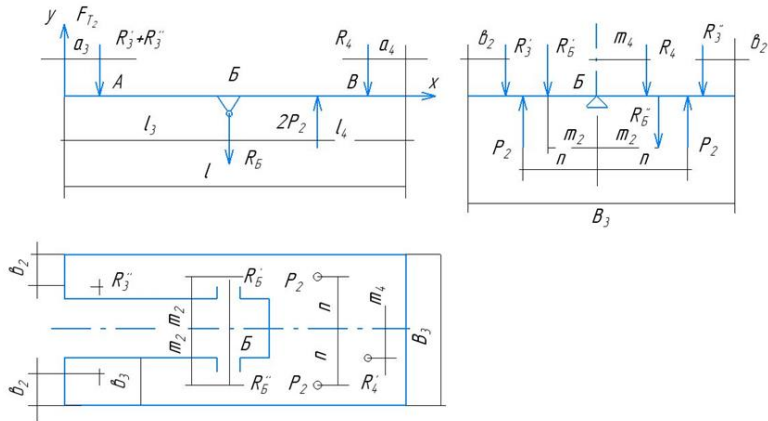

Figure 3.15. Design scheme of the overlapping part of the floor with a double-hinge connection

In the design scheme of the overlapping base part of the floor with a double-hinged connection (see Fig. 3.15), the displacements of the points of contact from the longitudinal axis of the floor are taken equal to $a_3=0,2l_3$; $a_4= 0,2l_4$; $b_3=0,3 B_3$.. Here b_3 should be no more than the protrusions of the cantilever parts b_3 .

To determine the reactions R_3' , R_3'' , R_4 and m , we compose a system of static equilibrium equations:

$$\sum M_V = (R_3 + R_3'')(L - a_3 - a_4) + (R_V' + R_V'')(l_7 - l_4 - a) - 2P_2(l_4 - a_4) = 0;$$

$$\sum M_V = (R_3' + R_3'')(0,5B_3 - b_3) - R_4m_4 = 0; \quad (3.32)$$

$$\sum Y = 2R_2 - R_3' - R_3'' - R_V' - R_V'' - R_4 = 0;$$

$$R_V' = R_V'' = 0,5R_V; \quad R_3' = 1,3R_3''$$

Overlappings and fencing of support-protective and protective-supporting types. The calculation of such supports (Fig. 3.16) is similar to the calculations of the supporting type, however, the design models also take into account the friction forces F_T ; F_{T1} and F_{T2} .

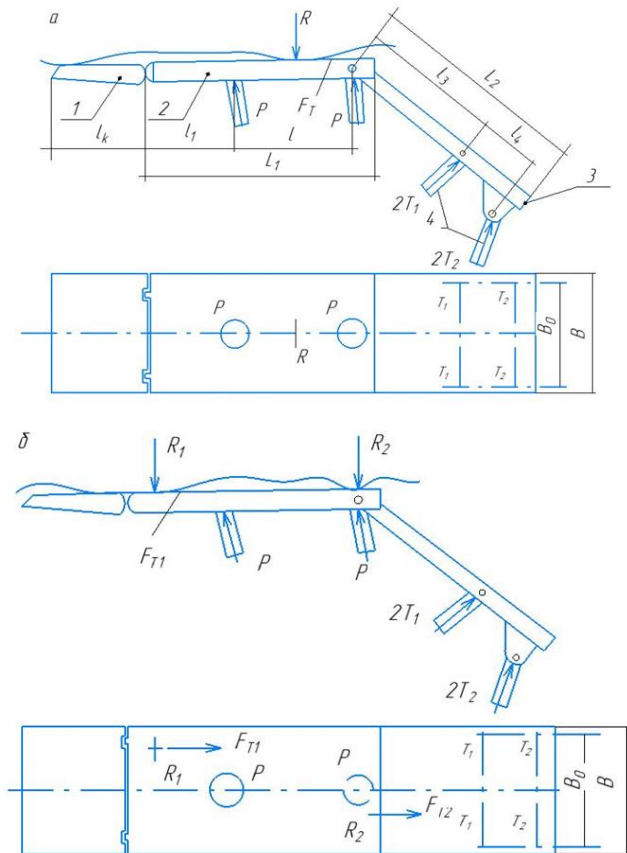

Figure 3.16. The scheme of interaction with the roof of the ceiling and the lining of the support-fencing type: 1 - articulated console; 2 - overlapping; 3-fence; 4 - levers

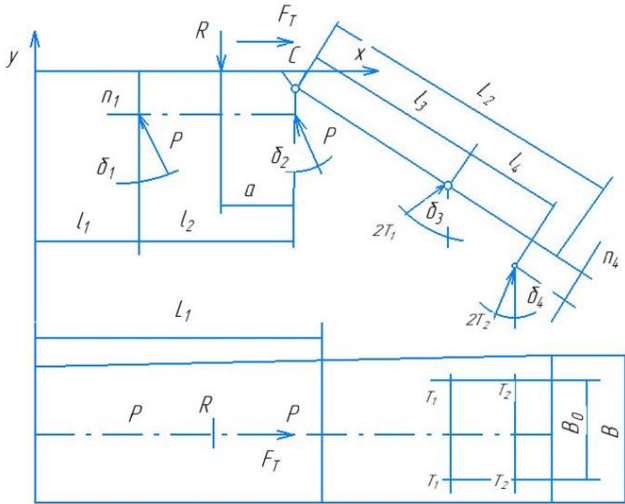

Figure 3.17. The design scheme of the overlap and fencing with single-point contact p Ceilings with a roof

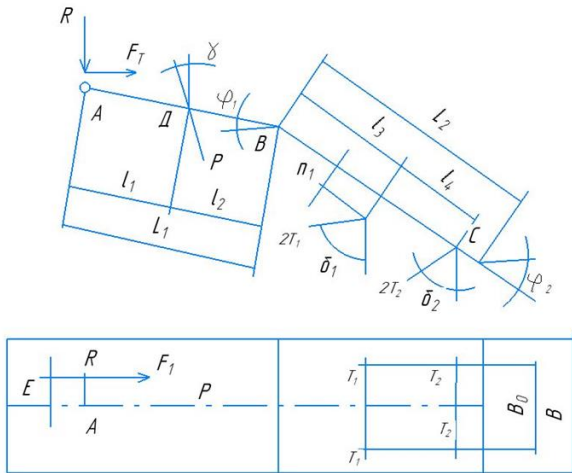

Figure 3.18. The design scheme of the fence

Coordinate a of the contact point of the overlap of the support-fencing type with a single-point contacting option (Fig. 3.17), the forces R , T_1 and T_2 are determined from the system of equations:

$$\begin{aligned}
 \sum X &= 2T_1 \sin \gamma_3 + 2T_2 \sin \gamma_4 + F_T - P(\sin \gamma_1 + \sin \gamma_2) = 0; \\
 \sum X &= 2T_1 \cos \gamma_3 + 2T_2 \cos \gamma_4 + P(\cos \gamma_1 + \cos \gamma_2) - R = 0; \\
 \sum M_c &= P(l_2 \cos \gamma_1 + h_1 \sin \gamma + h_1 \sin \gamma_2) - Ra + F_T h_2 = 0; \\
 &\quad \text{(left)} \\
 \sum M_{c \text{ (right)}} &= 2T_1 l_3 \cos(\gamma_3 - \varphi) + 2T_2(l_3 + l_4) \cos(\varphi - \gamma_4) - \\
 (3.33)
 \end{aligned}$$

$$\begin{aligned}
 2T_2 h_4 \sin(\varphi - \gamma_4) &= 0; \\
 F_T &= fR.
 \end{aligned}$$

Lining of the protective-supporting type is calculated in a similar way, for which a system of equations of static equilibrium is drawn up (Fig. 3.18):

$$\begin{aligned}
 \sum X &= F_T - P \sin \gamma + 2T_1 \sin \gamma_1 + 2T_2 \sin \gamma_2 = 0; & (3.34) \\
 \sum Y &= P \cos \gamma + 2T_1 \cos \gamma_1 + 2T_2 \cos \gamma_2 - R = 0; \\
 \sum M_c &= R[L_1 \cos \varphi_1 + (l_3 + l_4) \cos \varphi_2] - F_T[L_1 \sin \varphi_1 + \\
 &+ (l_3 + l_4) \sin \varphi_2] - P \cos \gamma [l_2 \cos \varphi_1 + (l_3 + l_4) \cos \varphi_2] + \\
 &+ P \sin \gamma [l_2 \sin \varphi_1 + (l_3 + l_4) \sin \varphi_2] - 2T_1 \cos(\gamma_1 - \\
 &\quad - \varphi_2)l_4 + 2T_1 \sin(\gamma_1 - \varphi_2)h_1 = 0.
 \end{aligned}$$

It is accepted $m = 15$ cm.

Determination of the initial data. The design resistance of support pillars P_t , intended for operation in longwalls with roofs of I, II and IV classes (classification of the former VUGI) is assumed to be equal to the nominal working resistance.

For supports operating in longwalls with hard-to-break roofs of the III class, the design resistance is taken to be 1.25 of the nominal.

The force on the cantilever spring is found by the formula:

$$R_k = f_k \frac{3EI}{\eta l_k^3}, \quad (3.35)$$

where f_k - console deflection, cm; $2,1 \times 10^7 H/cm^2$; η - coefficient of deformation, taken equal to 1.35; l_k – is the length of the spring, cm; I - moment of inertia of the spring section, cm^4 ; $I = g \cdot b_p \cdot \sum_{i=1}^n h_i^3 / 12$; g – number of lines in the overlap; b_p - spring width, cm; h_i – sheet thickness, cm; n - the number of sheets in the spring.

The magnitude of the forces R_i from the side rocks is determined from the static calculation formula. The friction forces acting on the overlap from the side rocks at the points of contact are:

$$F_{T_i} = f R_i \quad (3.36)$$

where R_i – is the force acting from the side rocks; f is the coefficient of friction of rock against metal, taken equal to 0.15 for wet rock and 0.4 for dry rock.

Determination of the geometric characteristics of sections, floors and railing. Cross-sections of slabs and fences have a complex shape. Total areas F , static moments S and moments of inertia I of such sections are formed as the sums of areas F_i , static moments S_i and moments of inertia I_i of individual constituent elementary geometric figures (rectangle, sector, etc.).

The calculated cross section is drawn to scale and broken down into individual simple shapes. Then the areas of these figures F , the coordinates of the centers of gravity Y_c and the moments of inertia I_x relative to the axis passing through the center of gravity of the section are set. The static moment of a geometric section of a complex shape is determined by the formula:

$$\sum S = \sum F_i Y_i \quad (3.37)$$

where F_i is the cross-sectional area of an elementary figure; Y_i - distance from the center of gravity of the area of the elementary figure to the axis.

In turn,

$$Y_i = \frac{\sum S}{F_i} \quad (3.38)$$

The moment of inertia of a section of a complex shape relative to the axis is determined by the formula:

$$I = \sum I_i + \sum F_i (Y_i')^2 \quad (3.39)$$

where Y_i is the distance from the center of gravity of the area of an elementary figure to the neutral axis of the section.

Section resistance moment:

$$W = \frac{I}{Y} \quad (3.40)$$

where Y is the distance from the axis passing through the center of gravity of the section to the considered fiber, see.

Calculation of sections of floors and railings. When calculating cross-sections, normal bending stresses σ_i and compression σ_c , shear stresses in bending τ_i and torsion τ_k .

Then, in all sections, the total normal and total shear stresses and the safety factor are determined. The latter is compared with the valid one. All seams of welded joints are also calculated. Allowable safety factor $n_d=1,3$. Strength condition n_c and n_d .

The procedure for calculating the strength of floors and fences is as follows:

1. Schemes of the interaction of the floor or fence with lateral rocks and the design schemes of sections in the required number of orthogonal projections are drawn, indicating all the required dimensions.
2. The material and all the necessary strength properties are selected, taking into account the heat treatment.
3. They are applied to the design diagram with the indication of coordinates: the forces R_i acting from the side rocks, and the forces in the hinges; resistance forces of the struts P_i ; forces acting from the roof on the front consoles R_k friction forces F_{T_i} ; efforts in T.
4. Diagrams of bending moments M_i , torsion moments M_k , and shear forces Q are plotted.
5. On the diagrams M_i , M_k , Q and drawings of structures, design (dangerous) sections are outlined.
6. Find the geometric characteristics of the sections F , S and I .
7. Bending stress σ_i and in the outer fibers, shear stresses from the torque τ_k , transverse bending τ_i and total τ are determined.
8. The safety margins are calculated for the yield point from normal and shear stresses, as well as the general ones in the outer fibers.
9. The strength condition is checked.

10. The stresses in the welded seams of the design section from shear forces τ_c , from the torque τ_k and total τ are recorded.

11. The safety margins of the welded seams are determined.

12. The conditions of strength of welded seams are checked.

Features of base structures. The base is the supporting element of the support sections, on which the hydraulic props and the soils in contact with the rocks rest.

For supports of the supporting-protective and protective-supporting types of the base, as a rule, they are hingedly connected to the four-link structure. The articulated joint and the four-link elements allow the overlap to rotate relative to the base in the plane of the seam by 7-10 °.

The bases of powered roof supports consist of side parts, on which the supports of the sections and connecting elements are supported. According to the number of base parts and the method of their connection, rigid bases of support-type supports are divided into solid and articulated.

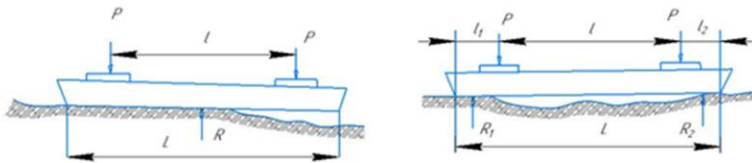

Figure 3.19. Scheme of interaction of the support base with soil rocks at one-point contact



Figure 3.20. Scheme of interaction of the support base with soil rocks at two-point contact

The foundations of the supporting-protective and protective-supporting types of supports are solid.

The basic parts of the base are beam or slab structures, consisting mainly of sheet metal and cast steel for the support elements for the support posts.

The schemes of interaction of bases with soil rocks can be very different, but the most common for a rigid solid foundation are two: 1) contact

with the soil in the middle of the racks at one point (Fig. 3.19); 2) contacting at the ends of the base at two points (Fig. 3.20).

The calculation of foundations is similar to the calculation of floors and railings. Equations of analytical equilibrium are also drawn up to determine the forces acting on the base, the geometric characteristics of the sections are calculated and the acting stresses are determined.

3.3. Calculation for the resistance of supports

General concepts of the stability of supports. In powered supports, there are two main types of stability disturbances - lateral and longitudinal overturning and shear along the dip and strike of the seam.

The support is stable in overturning when the moment of the overturning forces acting on the section relative to the axis passing inside the base contour (in the limit through the extreme point of the contour) is less than the moment of the holding forces.

When checking the shear stability, the shear forces acting on the support are compared with the holding forces on the contact surfaces of floors and joints with lateral rocks and structural elements (guide beams, springs, etc.).

In practice, there are problems of calculating the stability in four positions of the support: in the free position without the spacer of the struts; in the working position when the racks are spaced with a pressure corresponding to the moment when the safety valve is triggered; when moving the conveyor; when moving the racks themselves.

Calculation of the stability of the support sections against overturning in a free state. Stability conditions (Fig. 3.21) are determined by the expression:

$$GZ \sin \beta \ll Ga_0 \cos \beta. \quad (3.41)$$

from here:

$$\beta \ll \arctg \frac{a_0}{Z}. \quad (3.42)$$

where a_0 is the coordinate of the turning point, depending on the elasticity of the soil, m; Z is the coordinate of the center of gravity of the section at the maximum extension of the racks, m; G is the weight of the support section, kN; $2a$ - base width, m.

Accepted $a_0 = 0.9a$. The design limiting angle must be:

$$\beta = \beta_N + \Delta = 1,2\beta_N. \quad (3.43)$$

where β_N is the limiting angle of incidence of the formation, given by the operational and technical requirements.

At the same time, an elastic reducer is calculated from the condition of ensuring the return of the rack to its original position after its unloading. In this case, the moment from the return force of the elastic reducer M must be greater than the sum of the moments overturning the rack, from the component of the rack mass M_e and from the friction force in the lower support of the rack:

$$M_v \gg M_c + M_o. \quad (3.44)$$

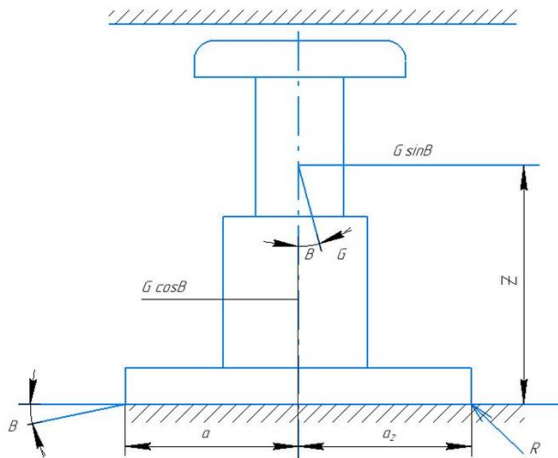

Figure 3.21. Diagram of the forces affecting the lateral stability of the section without spacing the struts in the free state and in the process of movement

Calculation of the stability of the support sections under rock pressure. For supports of protective-supporting type, stability is calculated according to two options for different extensions of hydraulic props

(minimum, nominal and maximum): with loaded supporting and protective elements; with only supporting elements loaded.

According to the first option, the resultant forces acting on the support elements are graphically determined. In the second case, it is similar, but with a load on the protective lining $P = 0$. Stability is considered to be ensured if the resultant passes no more than 1 in from the edge of the base.

For supports of the supporting type, the sufficiency of the elastic reducer stroke is checked (the absence of a rigid support of the strut at the base) under the action of the lateral rocks displacement.

Calculation of the stability of the support sections against their shift when moving the conveyor.

The stability of the support in this case is determined by the factor at which the maximum force Q_k developed by the jack of movement should be less than the friction forces F_1 and F_2 on the contact surfaces from the thrust forces of the struts (Fig. 3.22). Since $h_1 > h_2$, the greatest part of the load from Q_k is absorbed by the friction force F_2 , and the condition for the absence of section slip on the seam soil has the form:

$$Q_k = h_1 < F_2(h_1 + h_2), \tag{3.45}$$

and the stability margin is defined as:

$$n = \frac{F_2(h_1+h_2)}{Q_k h_1} \gg 1,3, \tag{3.46}$$

where Q_k is the maximum effort to move the conveyor.

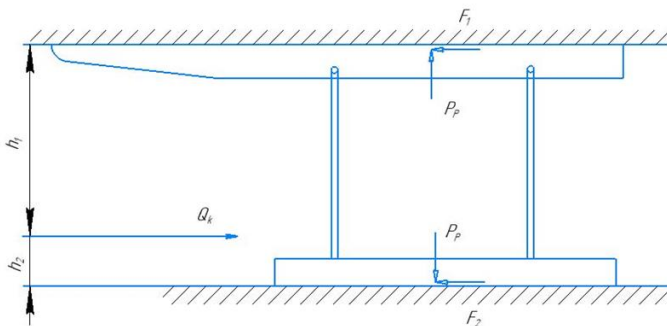

Figure 3.22. Loading scheme of the support section when moving the conveyor

3.4. Features of calculation of powered supports for powerful formations

As the initial data for the choice of the bearing capacity of the hydraulic props on the supporting part, the following load values are set (Fig. 3.23): a) on average $q_{avr} = 250 \text{ kN/m}^2$ with a trapezoid distribution from $q_0=50 \text{ kN/m}^2$ at the bottom to $q_1=450 \text{ kN/m}^2$ at the dam; b) on average $q_{avr} = 400 \text{ kN/m}^2$ with a trapezoid distribution from $q_0=50 \text{ kN/m}^2$ at the bottom to $q_1=750 \text{ kN/m}^2$ at the heap; c) on average $q_{avr} = 600 \text{ kN/m}^2$ with a trapezoid distribution from $q_0=100 \text{ kN/m}^2$ at the bottom to $q_1 = 1100 \text{ kN/m}^2$ at the heap.

The load on the protective part is assumed to be evenly distributed over the area: a) vertically in the upper part of the support $q_{2y} = 150 \text{ kN/m}^2$; b) horizontally in the upper part of the support $q_{2x} = 80 \text{ kN/m}^2$, in the lower $q_{3x} = 150 \text{ kN/m}^2$. The width of half of the support section is $b = 1.1 \text{ m}$.

To determine the force of interaction of the support with the face ledge and the soil, the following assumptions were introduced: the base structure is a rigid plate: the face ledge deformation is proportional to the possible displacements of the base; the specific pressure of the base on the bottom ledge is distributed along the contacting plane according to the trapezoidal law.

The actually possible coefficients of friction between the base of the support and the ledge, the base and the soil are taken as follows: $f_{min} = 0,2$; ; $f_{max} = 0,4$.

The choice of the bearing capacity of hydraulic props (direct calculation). Based on the given rock pressures, we determine the resistance of the hydraulic props. The calculation is performed in the following order (Fig. 3.23).

Load on the supporting part of the support:

$$Q = \frac{q_1+q_2}{2} l_1 b, \quad (3.47)$$

Where l_1 is the length of the supported roof strip.

The pressure of rocks on the enclosing parts is given in the form of evenly distributed components along the vertical and horizontal.

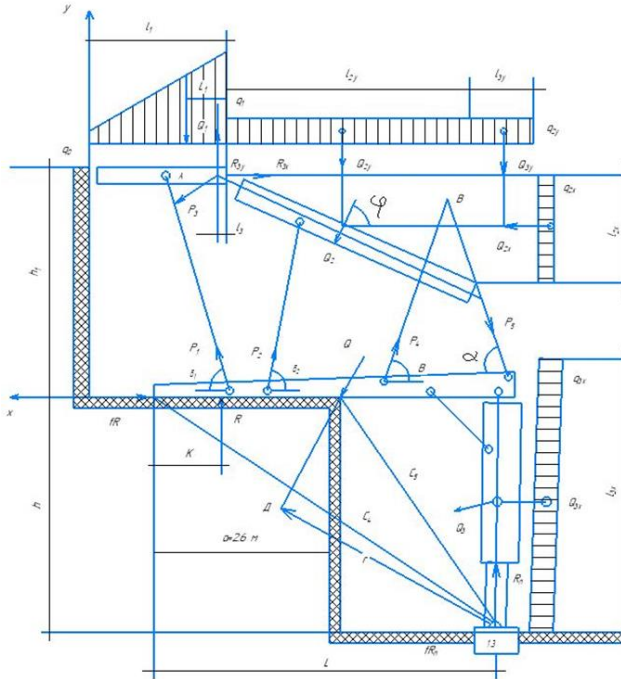

Figure 3.23. Design scheme of support MKP2U

Top railing load:

$$Q_{2y} = q_{2y}l_{2y}b; \quad (3.48)$$

$$Q_{2x} = q_{2x}l_{2x}b; \quad (3.49)$$

where l_{2y} is the length of the vertical load on the upper fence, m; l_{2x} is the length of the horizontal load on the upper fence, m.

Total pressure on the top guard:

$$Q_2 = \sqrt{Q_{2x}^2 + Q_{2y}^2}; \quad (3.50)$$

Lower railing guard:

$$Q_{3y} = q_{3y}l_{3y}b; \quad (3.51)$$

$$Q_{3x} = q_{2y}l_{2y}b; \quad (3.52)$$

where l_{3y} – length of vertical load on the bottom guard m; l_{3x} – length of horizontal load on the bottom guard, m.

Total pressure on the bottom guard:

$$Q_3 = \sqrt{Q_{3y}^2 + Q_{3x}^2}; \quad (3.53)$$

The shoulder L1 of the force Q1, i.e., the distance of the point of application of the equal, is found by the formula:

$$L_1 = \frac{l_1}{3} \cdot \frac{2q_0 + q_1}{q_0 + q_1}. \quad (3.54)$$

The load points Q_2 and Q_3 are recorded graphically. The resultant of all loads on the support is determined by the construction of the power polygon. The side of this polygon replaces in magnitude and direction the sought resultant Q. The line of action Q is found from the construction of the rope polygon, then the shoulder of the resultant changes to the point D-r (m).

Let us assume that the deformation of the ledge-bottom is proportional to the possible displacements of the base. Find the shoulder of the reaction of the step (R) from the beginning of the base k:

$$\frac{q_4}{q_5} = \frac{c_4}{c_5}; \quad (3.55)$$

$$k = \frac{a}{3} \cdot \frac{q_4 + 5}{q_4 + 5'}; \quad (3.56)$$

where q_4 and q_5 - specific pressure on the ledge, kN / cm^2 ; c_4 and c_5 - distance from the axis of rotation of the base to the line of contact of the upper base with the step.

The shoulder pressure is determined from the condition $\sum M_D = 0$:

$$Qr - R(L - k) - Rhf = 0, \quad (3.57)$$

where L is the length of the upper support base, m; h - bottom face height, m.

Soil reaction is set:

$$R_p = Q_y - R, \quad (3.58)$$

where Q_x - the vertical component of the resultant Q .

The horizontal component is balanced by the frictional forces on the ledge and horizontal movement jacks. Hence, the jacks of movement account for:

$$P_d = Q_x - f(R + R_p), \quad (3.59)$$

where Q_x - the horizontal component of the resultant.

For R and R_p , the extreme values of these values are found at f_{min} and f_{max} , and for the movement jack, the range of possible efforts:

$$P_{min} \ll P_d \ll P_{max}.$$

To calculate the forces in the hydraulic props and levers of the four-link system, consider the upper part of the support. We split it into two parts and compose the equilibrium equation separately for the left (in the analytical part of the calculation with the arrow \leftarrow) and right (with the arrow \rightarrow) part of the system:

$$\leftarrow \sum M_a = 0, \quad P_1 a_1 - Q_1 a_{Q_1} = 0; \quad (3.60)$$

$$\sum X = 0, \quad P_1 \cos \delta_1 - P_3 x = 0; \quad (3.61)$$

$$\sum Y = 0, \quad P_1 \sin \delta_1 - P_3 y + Q_1 = 0; \quad (3.62)$$

$$\rightarrow \sum M_b = 0, \quad -P_{3y} l_y - P_{3x} b_x + P_2 b_2 - Q_2 l_{Q_2} = 0; \quad (3.63)$$

$$\sum M_A = 0, \quad P_2 a_2 - Q_2 a_{Q_2} + P_4 a_4 - P_2 a_5 = 0; \quad (3.64)$$

$$\sum Y = 0, \quad -P_{3y} + P_2 \sin \delta_2 - Q_2 \sin \varphi - P_4 \sin \beta - P_5 \sin \alpha = 0; \quad (3.65)$$

The shoulders of forces will be denoted by the letters of those points relative to which the moments of forces with the force index are taken. We take the lengths of the shoulders and the magnitudes of the angles by scale.

Calculation of the power mode of the support (reverse calculation). The initial data for the reverse calculation are the bearing capacity of the hydraulic props and the pressure of the rocks on the upper and lower fence, which is assumed to be the same as in the direct calculation, i.e. $q_{2y}=150 \text{ kN/m}^2$; $q_{2x}=80 \text{ kN/m}^2$; $q_{3x}=150 \text{ kN/m}^2$.

The same assumptions remain as in the direct calculation, and the same realistically possible coefficients of friction between the base of the support and the bench, the base and the soil.

The calculation is performed in the following order. The upper part of the support is considered, and from the equilibrium equation for the left and right parts, the load on the supporting part of the support, the diagram of the load and force in the rods of the four-link structure are determined. Then the value, direction and position of the resultant Q from the given rock pressures on the fence and the newly found pressures on the supporting part are determined lining.

The line of action Q is found from the construction of the rope polygon, the shoulder of the resultant is measured to point D .

The reaction of the step is determined from the condition $\sum M_d = 0$, taking into account the actually possible coefficients of friction.

The reaction of the soil and the forces in the jacks of movement, the linear dimensions of the loads, the shoulders of the forces, the angles of inclination of the support elements remain the same as in the direct calculation.

3.5. Overlapping calculation fenced (shield) of power supports

The main bearing element of the supports under consideration is the overlap, which receives the rock pressure through the canopy. Taking into account that the law of rock pressure distribution on the canopy along the Z axis does not affect the type of deformation of the floor, we only investigate its changes along the X axis. In the latter case, it can have the probable variants shown in Fig. 3.24.

When the resultant of external forces passes through the center of gravity of the canopy, the support works only for transverse bending, therefore, such a distribution of the load on the canopy is more favorable and less dangerous during the operation of the support, and the calculation of its elements is greatly simplified.

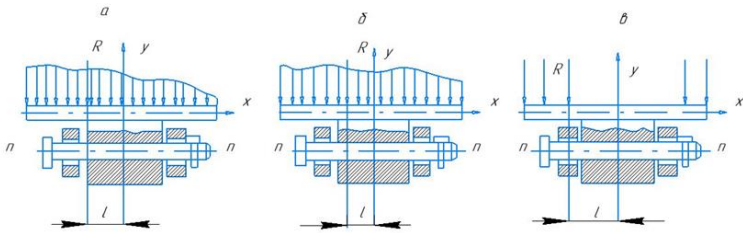

Figure 3.24. Possible options (a - c) of the support load through the canopy

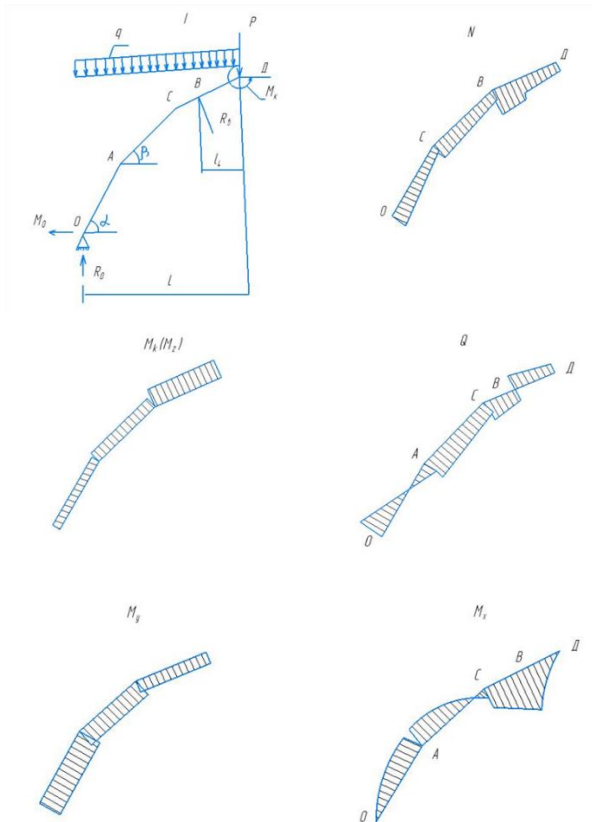

Figure 3.25. Design scheme of the protective element of the section:
roof supports (I); moment diagrams M_k and M_y (II);
shear force diagrams (N , Q) and bending

In other cases, the resultant of external forces is eccentric. In addition to bending moments in the vertical plane, there is also a torque $M_k=R_e$, the vector of which coincides with the Z axis.

In this case, the torque vector does not coincide with the axes of the remaining sections of the overlap of the support. Then, bending moments appear in these sections in the horizontal plane as well. For example, in the DC section (Fig. 3.25), a horizontal bending moment $M_i = M_k \sin \beta$ occurs, and in the CA section $M_i = M_k \sin \beta$, etc. In addition, the pressure of the collapsed rocks on the floors can be taken as uniformly distributed load with intensity q .

The rock pressure on the visor has a horizontal component, in some cases reaching significant values. It is not always true that the assumption of uniform distribution of the load (weight of the collapsed rocks) on the floor is also not true. However, these components of the rock pressure do not affect the type of deformation of the floor and are necessary only for a quantitative analysis of the internal force factors for a given or known law of distribution of these loads. They are easily taken into account when calculating the elements of the support, therefore, here we consider the calculation of the overlap of the powered support in a complex loaded state.

In the cross-sections of the roof support, five internal force factors arise: three moments and two forces (M_k, M_x, M_y, Q, N). An analytical study of the distribution of internal force factors in the overlap of the support shows that the section at point B, where the force of the spacer jack is applied, is dangerous. Although in the section OA the bending moment has an extremum, this value, the value of which is found from the relation:

$$M_{ext} = R_0 l_{ext} - \frac{q l_{ext}^2}{2} + H_0 l_{ext}, \quad (3.66)$$

less than the bending moment in section B, determined by the expression:

$$M_B = R_0(L - l_4) - \frac{q(L-l_4)^2}{2} + H(L - l_4)tg\alpha. \quad (3.67)$$

Here:

$$l_{ext} = \frac{H_0 \sin \alpha + R_0 \cos \alpha}{q \cos \alpha},$$

where R_0, H_0 , - vertical and horizontal components of the support reaction at point O; L - horizontal projection of the roof support; l_4 -

horizontal projection of the fourth section of the roof support; α -angle of inclination of the roof support section.

When checking the strength of section B, it is necessary to investigate the stress state at points 1-4 (Fig. 3.26).

At point 1, when $\tau_1 = 0$, the strength condition has the form:

$$\sigma_{cal} = \frac{N}{F} + \frac{M_x}{W_x} + \frac{M_y}{W_y} \ll [\sigma], \quad (3.68)$$

where N - longitudinal forces in section B; M_x - bending moment in the YOZ plane; M - the same, XOZ; W, W, - moments of resistance relative to the X, Y axes.

At point 2, the stresses are determined by the formula:

$$\sigma_2 = \frac{N}{F} + \frac{M_x}{W_x}; \quad \tau_2 = \tau_{max} = \frac{W_{k1}}{W_{k1}}; \quad (3.69)$$

Here:

$$W_{k1} = 2b_0h_0\delta_2,$$

where b_0 is the calculated section width; h_0 - calculated section height; δ_2 - thickness of horizontal sheets.

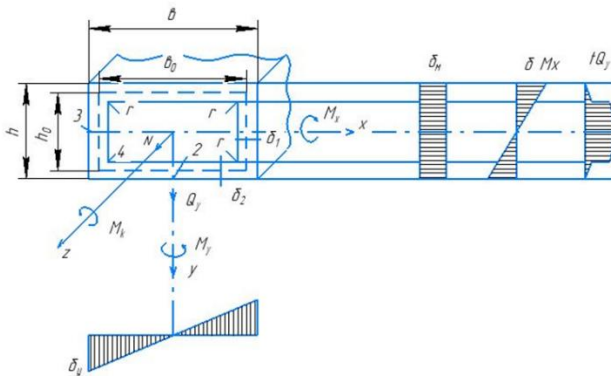

Figure 3.26. Design scheme of section B of roof support

The strength condition has the form (third strength theory):

$$\sigma_{cal} = \sqrt{\sigma_2^2 + 4\tau_2^2} \ll [\sigma]. \quad (3.70)$$

At point 3, the voltages are:

$$\sigma_3 = \frac{N}{F} + \frac{M_y}{W_y}; \quad \tau_3 = \frac{W_k}{W_{k1}}; \quad (3.71)$$

Here:

$$W_k = 2b_0h_0\delta_2$$

where δ_v -is the thickness of vertical sheets.

Therefore, the strength condition will be written as follows:

$$\sigma_{cal} = \sqrt{\sigma_3^2 + 4\tau_3^2} \ll [\sigma] \quad (3.72)$$

For large values, it is necessary to check the strength condition of the section B at point 4. In this case, the shear stresses are determined from the sum of the two stresses, i.e.:

$$\tau_4 = \tau_4^{M_k} + \tau_4^Q; \quad (3.73)$$

$$\tau_4^{M_k} = \frac{M_k}{M_k}; \quad \tau_4^Q = \frac{QS_x^{cut}}{I_x b_4},$$

where Q is the shear force; S_x^{cut} is the static moment of the cut-off part; I_x - moment of inertia; b_4 - working width of section B, equal to 2δ .

It is necessary to take into account that a high concentration of stresses is observed in the inner corners, sometimes reaching the yield point of the material, therefore it is desirable to have in these places the rounding shown in Fig. 3.26.

3.6. Calculation of construction elements mechanized walking supports supporting type

Domestic mechanized (M87, 2M81E, MK97, "Donbass", etc.), as well as foreign (Wild, Gall-Wing, etc.) roof supports do not fully ensure reliable roof pickup following the passage of the combine, without removing the loads from the spacer posts section. In the process of movement of the roof support section, repeated trampling is performed, followed by deformation of the rocks of the immediate roof.

To eliminate the indicated drawbacks of the existing supports (reducing the lowering of the roof, effectively picking up the roof following the passage of the harvester and increasing the resistance of the section), the Karaganda Polytechnic Institute proposed a special walking support KShM-1, equipped with an overlap with a groove for placing the upper supporting area of the middle post with a hinged top. The third (downhole) rack in the process of movement of the section, hingedly leaning towards the bottom of the face, reliably picks up the roof immediately behind the aisle of the combine. At the same time, some lining support constantly expands the roof, thereby reducing the subsidence (convergence) of the roof rocks.

In fig. 3.27 shows a section of a powered walking support, consisting of an overlap 5 with a sprung canopy, which in the bottomhole part is pivotally connected to a post 1, installed together with a post 2 on the base 7. From the bottom side, the overlap 5 rests on a post 3. There is a special groove in the overlap, where the upper support area 8 moves with the hinged top 9 of the rack 2. The base 7 of the racks 1, 2 is connected to the base 6 of the rack 3 by a hydraulic jack of movement 4.

The complex equipped with such a support operates in the following mode. Following the passage of the harvester, racks 1 and 3 are unloaded. With the help of a hydraulic jack 4, the overlap of the support 5, as well as the rack 3, installed on the base 6, are pulled to the bottom of the face. Overlap 5, moving to the face chest, tilts rack 1 and 3 expand and press the ceiling 5 to the roof.

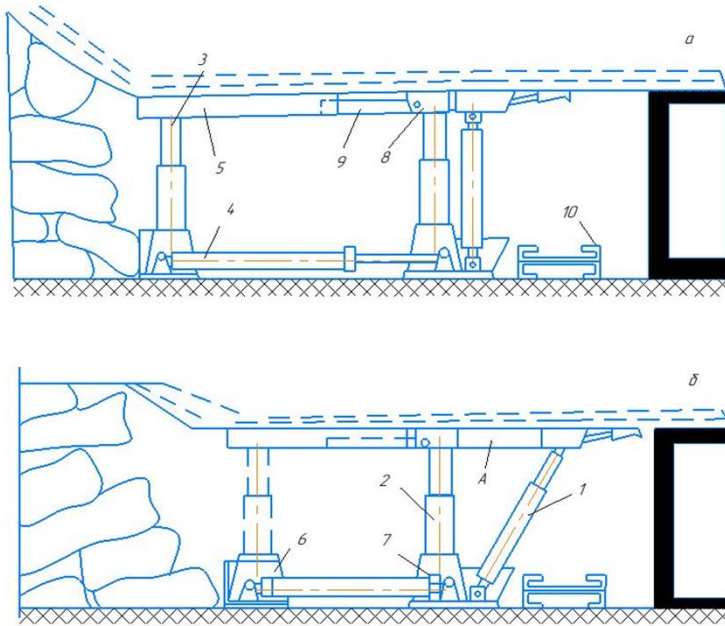

Figure 3.27. Scheme of the operation of the KShM-1 powered walking support:
a - at the time of the combine's passage;
b - after moving the landing row of the support section

During the movement of floor 5 with posts 1 and 3 to the bottom of the face, the roof is supported by post 2, the upper support area of which is located in groove A of floor 5. Then, with a lag of 10-15 m from the combine, the curving face conveyor 10 with base 7 moves, on which installed racks 1 and 2, after which rack 1 again takes up the vertical (original) position and racks 1, 2 and 3 reliably expand the roof. In this case, the unsecured part of the roof, where the groove A of the overlap 5 is located, is completely tightened by the upper support area 8 of the pillar 2 with the hinged top 9. This completes the working cycle for fixing the face, and the support is ready to excavate the next coal strip.

Racks 1, 2 and 3 are made on the basis of Sputnik-IV hydraulic bollards with a working diameter of 200 mm, so the section resistance is in the range of 2000-2700 kN, which is very important when developing seams a_5 and a_7 with hard-to-break roof rocks of the Ashlyarik suite of the Karaganda basin, where the laborious process of roof management is applied

- the method of forward torpedoeing of the rocks of the main roof to a depth of 40-60 m.

The proposed structure of the support completely or partially excludes the convergence of rocks of the immediate and main roof.

Research and determination of the expansion forces of the support section. The study of the interaction of supports with roof rocks shows that it is impossible to choose an unambiguous design scheme. In work [11], the results of studies of the interaction of powered supports with enclosing rocks in various mining and geological conditions are presented in some detail. The analysis of the given data emphasizes that, despite the abundance of various options for loading the lining, it is possible to select a function that approximately describes the general pattern of distribution of external forces on the lining of the lining. In this case, particular cases are specified (implemented) using the coefficients of the selected function.

. As a first approximation, it is advisable to consider the loading scheme, taking a linear solid load in the form of a trapezoid. By varying the values of q_1 and q_2 (Fig. 3.28), you can set the extreme values of the forces in the uprights, depending on the geometric parameters of powered supports.

The main linear dimensions of the KShM-1 support are as follows: $l=331$ cm; $l_1=32$ cm; $l_2=219$ cm; ; $l_3=80$ cm.

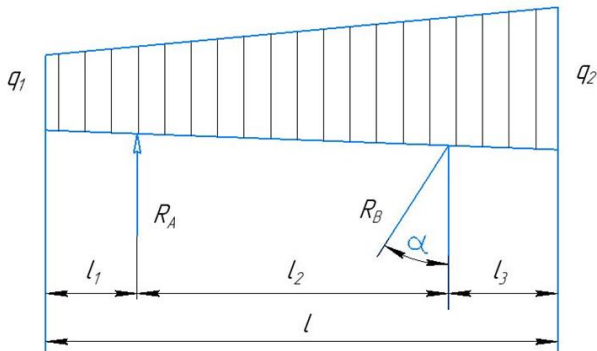

Figure 3.28. Design scheme for loading the roof support KShM-1
At the given values, the reaction of the lining is equal to:

$$R_A = \frac{q_2(l - 3l_3) + q_1(2l_1 - 2l_3)}{6l_2};$$

$$R_A = \frac{q_2(3l_2 + 3l_3 - l) + q_1(3l_2 - 3l_3 - 2l)}{6l_2 \cos \alpha};$$

$$H_B = R_B \sin \alpha = f_{friction} N$$

$$N = \frac{q_1 + q_2}{2} l;$$

Finally:

$$R_A = (0,91q_2 + 4,22q_1) \cdot 25,2; \quad (3.74)$$

$$R_V = (5,66q_2 + 2,35q_1) \cdot \frac{25,2}{\cos \alpha}; \quad (3.75)$$

$$H_V = R_V \sin \alpha. \quad (3.76)$$

Using formulas (3.74) - (3.76), we find the reactions of the KShM-1 lining (R_A , R_V and H_V) depending on the angle of inclination α of the front strut, the depth of the face and varying the values of q_1 and q_2 .

For a preliminary calculation of the KShM-1 lining, we take the following data: depth of occurrence - 400 m; the slope of the front pillar is 30°. With these parameters $R_A = 130$ kN; $R_V = 230$ kN and $H_V = 120$ kN.

Calculation of racks. Based on the above, we can assume that the struts of a given support experience only central compression. Therefore, two calculations must be made for them: for strength and for stability.

The calculation of the strength of the support struts, as is known, is reduced to the satisfaction of the following inequality:

$$\frac{R_i}{W} \leq [\sigma], \quad (3.77)$$

where R_i - is the maximum pressure on the support struts; W is the axial moment of resistance of the section of the corresponding rack; $[\sigma]$ - permissible stress.

The calculation was made with the following initial data: $R_A = 130$ kN; $R_V = 230$ kN; $[\sigma] = 160$ MPa; $d = 16$ cm; $d_2 = 20$ cm; $d_1 = 24$ cm.

Then for the top of the rack $W_{x_V} = \frac{\pi d_1^3}{32} = 402 \text{ cm}^3$, and for the bottom $W_{x_V} = \frac{\pi d^2}{32} (1 - \alpha^n) \approx 638 \text{ cm}^3$, where $\alpha = \frac{d_2}{d}$.

The calculation shows that at the given values of R_A , R_V , H_V and W for the racks, the condition is met

The stability analysis is reduced to determining the critical force for a bar with two sections of different stiffness (Fig. 3.29) under the boundary conditions:

$$Z = 0 \Rightarrow Y_1 = 0; \quad Z_1 = l_1 = Z_2 \Rightarrow Y_1 = Y_2 \text{ and } Y_1' = Y_2'; \quad Z = l \Rightarrow Y_2 = 0$$

Accordingly, for the upper and lower sections, we obtain the equations:

$$EI_1 Y_1'' + R_i Y_1 = 0;$$

$$EI_2 Y_2'' + R_i Y_2 = 0. \quad (3.78)$$

We denote:

$$\frac{I_2}{I_1} = \beta^2 \text{ and } \frac{R_i}{\beta^2 EI_1} = k^2.$$

Then:

$$Y_1'' + \beta^2 k^2 Y_1 = 0;$$

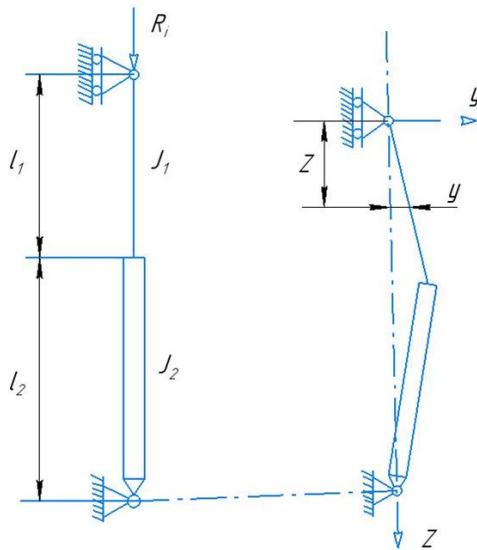

Figure 3.29. Scheme for calculating the hydraulic prop for stability

$$Y_2'' + k^2 Y_2 = 0.$$

From here:

$$Y_1 = C_1 \sin \beta k Z_1 + C_2 \cos \beta k Z_1;$$

$$Y_2 = C_3 \sin k Z_2 + C_4 \cos k Z_2. \quad (3.79)$$

From the condition that at $Z = 0$ the deflection is $Y_1 = 0$, we obtain $C_2 = 0$.

Solutions to the remaining conditions give:

$$\begin{cases} C_1 \sin \beta k l_1 = C_3 \sin k l_1 + C_4 \cos k l; \\ \beta C_1 \cos \beta k l_1 = C_3 \sin k l_1 - C_4 \sin k l \\ C_3 \sin k l + C_4 \cos k l = 0 \end{cases} \quad (3.80)$$

An approximate solution of this system shows that the elements of the racks under a given force R_i do not lose their design stability. After refinement, R_i (3.80) must be solved by an exact method.

Calculation of roof support overlap. Formulation of the problem. The overlap of the lining is influenced by rock pressure, which is transmitted through the contacting rock strata with the heel, and from below it is supported by the struts. Stance actions can be thought of as concentrated forces. If the ceiling is taken as a base, that is, the support is “turned over” by 180° , then the overlap of the support will be a slab on an elastic foundation. Considering that the ratio of the width b to the length of the floor is more than 3, it is quite acceptable to consider it as a beam on an elastic foundation.

The bending of a slab on an elastic foundation can be investigated by solving a beam of unlimited length on an elastic foundation. In this case, it is considered that the beam along its entire length rests on a solid base and the intensity of the uniformly distributed reaction at each point is proportional to the deflection at this point. Under such conditions, the reaction per unit length of the beam can be represented by the expression KY , in which Y is the deflection and K is a constant number, usually called the foundation factor. This assumption gives satisfactory results in many cases.

The general solution to the curved axis differential equation can be represented as follows:

$$Y = e^{\beta x}(A \cos \beta x + B \sin \beta x) + e^{-3x}(C \cos \beta x + D \sin \beta x), \quad (3.81)$$

Where:

$$\beta = \sqrt{\frac{k}{4EI_z}} \quad (3.82)$$

Integration constants should be determined from known conditions for some points. For example, for the case of one concentrated load acting on an infinitely long beam, the following solution can be obtained:

$$Y = \frac{P\beta}{2k} e^{-\beta x} (\cos \beta x + \sin \beta x). \quad (3.83)$$

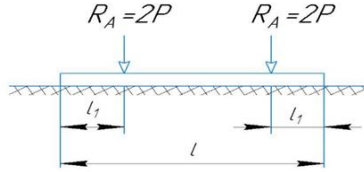

Figure 3.30. The design scheme for coverings for the symmetric problem

On the basis of equation (3.83) using the superposition principle, the problem posed can be solved. To achieve the goal, consider the case of a beam of finite length with free ends, which is loaded by two symmetrically applied forces R_A (Fig. 3.30). With this setting, the values of M_0 and Q_0 are obtained from the equations:

$$\frac{P}{4\beta} \{\psi[\beta(l - l_1)] + \psi(\beta l_1)\} + \frac{Q_0}{4\beta} [1 + \psi(\beta l)] + \frac{M_0}{2} [1 + \Theta(\beta l)] = 0; \quad (3.84)$$

$$\frac{P}{2} \{\Theta[\beta(l - l_1)] + \Theta(\beta l_1)\} + \frac{Q_0}{2} [1 + \Theta(\beta l)] + \frac{M_0\beta}{2} [1 + \varphi(\beta l)] = 0$$

After Q_0 and M_0 are found, the deflection and bending moment in any cross section of the actual beam can be obtained using the equations:

$$Y_{Q_0} = \frac{Q_0\beta}{2k} \varphi(\beta x); \quad Y' = \frac{Q_0\beta^3}{k} \xi(\beta x); \quad (3.85)$$

$$M_{Q_0} = \frac{Q_0}{4\beta} \psi(\beta x); \quad (3.86)$$

$$Y_{M_0} = \frac{M_0\beta^2}{k} \xi(\beta x); \quad Y' = \frac{M_0\beta^3}{k} \psi(\beta x); \quad (3.87)$$

$$M_{M_0} = \frac{M_0}{2} \Theta(\beta x), \quad (3.88)$$

Where:

$$\psi(\beta x) = -e^{-\beta x} (\sin \beta x - \cos \beta x);$$

$$\xi(\beta x) = e^{-\beta x} \sin \beta x;$$

$$\Theta(\beta x) = e^{-\beta x} \cos \beta x; \quad (3.89)$$

$$\varphi(\beta x) = e^{-\beta x}(\sin \beta x - \cos \beta x).$$

The method used for the symmetric problem can also be used for the asymmetric one shown in Fig. 3.31. To determine the proper values for Q_0 and M_0 , one can write a system of equations similar to equations (3.84):

$$\frac{P}{4\beta} \{\psi(\beta l_1) - \psi[\beta(l - l_1)]\} + \frac{Q_0}{4\beta} [1 - \psi(\beta l_1)] + \frac{M_0}{2} [1 - \Theta(\beta l)] = 0; \quad (3.90)$$

$$\frac{P}{2} \{\Theta(\beta l_1) + \Theta[\beta(l - l_1)]\} + \frac{Q_0}{2} [1 + \Theta(\beta l)] + \frac{M_0\beta}{2} [1 + \varphi(\beta l)] = 0.$$

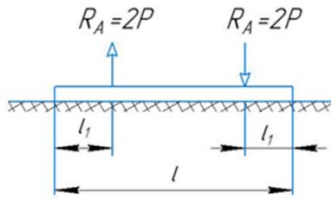

Figure 3.31. Design scheme of overlap under loading by asymmetric weights

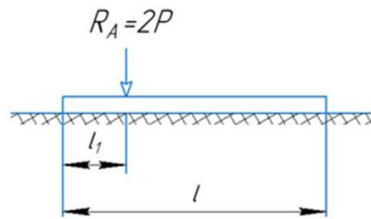

Figure 3.32. Calculation scheme of overlapping for an asymmetric problem

Once Q_0 and M_0 have been calculated, all the necessary parameters concerning the bending of the beam can be easily obtained using equations (3.85) – (3.88). Having a solution for symmetric and asymmetric loading of a beam, it is easy to derive a solution for any type of loading using the overlay principle. For example, the solution for the asymmetric case shown in Fig. 3.32 is obtained by superimposing solutions (3.85) and (3.90). Having solved this system, we will have:

$$M_0 = \frac{P}{3\beta} [\Theta(\beta l_1) - \psi(\beta l_1)]; \quad (3.91)$$

$$Q_0 = \frac{P}{3} [2\Theta(\beta l_1) - \psi(\beta l_1)]. \quad (3.92)$$

Having a solution (3.91), (3.92) and (3.85) – (3.88), it is easy to obtain the final result for the problem posed.

$$M_0^{total} = \frac{R_A}{6\beta} [\Theta(\beta l_1) - \psi(\beta l_1)] + \frac{R_V}{6\beta} \{\Theta[\beta(l - l_3)] - \psi[\beta(l - l_3)]\}; \quad (3.93)$$

$$Q_0^{total} = -\frac{R_A}{6} [2\Theta(\beta l_1) - \psi(\beta l_1)] + \frac{R_V}{6} \{2\Theta[\beta(l - l_3)] - \psi[\beta(l - l_3)]\}; \quad (3.94)$$

$$Y_{total} = \frac{\beta \cdot \varphi(\beta x)}{2k} Q_0^{total} - \frac{\beta^2 \xi(\beta x)}{k} M_0^{total}; \quad (3.95)$$

$$M_{total} = \frac{\psi(\beta x)}{4\beta} Q_0^{total} - \frac{\Theta(\beta x)}{2} M_0^{total}. \quad (3.96)$$

Let's transform the last equation:

$$M_{total} = \left[\frac{Q_0^{total}}{4\beta} \cdot e^{-3x} (\cos \beta x - \sin \beta x) + \frac{M_0^{total}}{2} \cdot e^{-3x} \cos \beta x \right] = \left[\frac{Q_0^{total} + \beta M_0^{total}}{4\beta} \cos \beta x - \frac{Q_0^{total}}{4\beta} \sin \beta x \right] e^{-\beta x}. \quad (3.97)$$

The maximum bending moment is determined from the condition:

$$\frac{dM_{total}}{dx} = 0, \text{ i.e. when } x = \frac{1}{\beta} \arctg \frac{2Q_{total} + \beta M_{total}}{\beta M}. \quad (3.97)$$

The greatest stress in the floor from bending will be:

$$\sigma_{max} = \frac{M_{max}}{W}, \quad (3.98)$$

where W is the moment of resistance of the weakened part.

Calculation of the middle support leg. Design and creation of KShM-1 powered roof support includes a set of issues. One of the central ones is the determination of the parameters of the middle support leg. This is due to the fact that the middle post fulfills the following conditions: 1) plays the role of an additional support and works as a compressed rod; 2) plays the role of an executive body and thereby eliminates the hanging of the roof.

In the first case, the calculation is reduced to a study of strength and stability. Consider in detail the second option, where the parameters of the middle pillar should be determined taking into account the optimal step of destruction of the ceiling. The solution to this issue depends on the knowledge of the stress state of the ceiling as a whole, and the vicinity of the action of the middle pillar.

The tense state of the ceiling. Investigations on the destruction of the under-roof coal pack by static compression and the stress state of the massif in the area of the working face with powered support were carried out by S. S. Zhetesov and A. Tusupov. The results of analytical studies are presented in [11]. The problem posed can be reduced to the aforementioned case. Then the design scheme for determining the stress state will be presented in the form shown in Fig. 3.33.

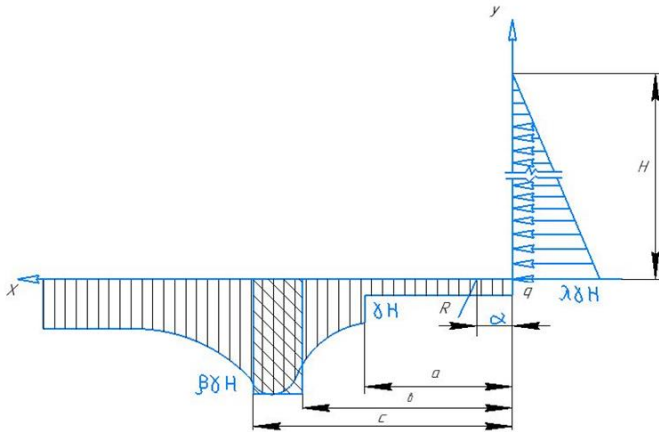

Figure 3.33. Calculation scheme for determining the stress state of the mountain massif of the ceiling

The stress state of the ceiling is expressed by the stress components σ_x , σ_y , σ_z and τ_{xy} found in [14]. For given dimensions, these stresses can be derived from the following relationships:

$$\begin{aligned} \sigma_x = & \frac{R \cos \alpha}{4\pi} \left\{ \frac{\varphi(x-d)^2 - y^3}{[y^2 + (x-d)^2]^2} + \frac{4xy(x+d) - y(x+d)^2 + y^3}{[y^2 + (x+d)^2]^2} + K_1 \right\} + \\ & + \frac{q}{4\pi} \left[\frac{y(x-a)}{[y^2 + (x-a)^2]} - \frac{y(x-a)}{y^2 + (x+a)^2} \right] + \frac{\gamma H}{4\pi} \left[\frac{y(x-a)}{[y^2 + (x+a)^2]} - \right. \\ & \left. - \frac{y(x-a)}{y^2 + (x-a)^2} \right] + \frac{\beta \gamma H}{4\pi} \left[\frac{y(x-c)}{y^2 + (x+c)^2} - \frac{y(x-c)}{y^2 + (x-ac)^2} - \right. \end{aligned}$$

$$-\frac{y(x-b)}{y^2+(x-b)^2} + \frac{y(x-b)}{y^2+(x+b)^2} \Big] + \sum_{i=0}^{i=m} \gamma \frac{H(m-i)}{m} \left[\frac{x(y-u_{i+1})}{x^2-(y-u_{i+1})^2} - \frac{x(y-u_i)}{x^2+(y-u_i)^2} - \frac{x(y-u_{i+1})}{x^2+(y+u_{i+1})^2} + \frac{x(y-u_{i+1})}{x^2+(y+u_{i+1})^2} \right]. \quad (3.99)$$

$$\begin{aligned} \sigma_y = & \frac{R \cos \alpha}{4\pi} \left\{ \frac{3y^2 + y(x-d)^2}{[y^2 + (x-d)^2]^2} + \frac{3y^2 + y(x+d)^2 - 4xy(x+d)}{[y^2 + (x+d)^2]^2} + K_1 \right\} \\ & + \frac{q}{4\pi} \left[\frac{2xy}{y^2 + (x+a)^2} - \frac{y(x-a)}{y^2 + (x-a)^2} - \frac{xy}{y^2 + x^2} + 3\text{arctg} \frac{x+a}{y} - \right. \\ & \left. - 2\text{arctg} \frac{x-a}{y} - \text{artg} \frac{x}{y} \right] + \frac{\gamma H}{4\pi} \left[\frac{\pi}{2} + \frac{y(x-a)}{y^2 + (x-a)^2} - \right. \\ & \left. - \frac{2xy}{y^2 + (x+a)^2} + -2\text{arctg} \frac{x-a}{y} - 3\text{arctg} \frac{x+a}{y} \right] \\ & + \frac{\beta \gamma H}{4\pi} \left[\frac{2xy}{y^2 + (x+c)^2} - \right. \\ & \left. - \frac{y(x-c)}{y^2 + (x-c)^2} - \frac{2xy}{y^2 + (x+b)^2} + \frac{y(x-b)}{y^2 + (x-b)^2} + \right. \\ & \left. + 3\text{arctg} \frac{x+c}{y} - 2\text{arctg} \frac{x-c}{y} - 3\text{arctg} \frac{x+b}{y} + 2\text{arctg} \frac{x-c_2}{y} \right] + \\ & \sum_{i=0}^{i=m} \gamma H \frac{m-1}{m} \left[\frac{2xy}{x^2 + (y+u_{i+1})^2} + 3\text{arctg} \frac{y+u_{i+1}}{x} - \frac{x(y-u_{i+1})}{x^2 + (y-u_{i+1})^2} - \right. \\ & \left. - 2\text{arctg} \frac{y-u_{i+1}}{x} - \frac{2xy}{y^2 + (x+u_i)^2} - 3\text{arctg} \frac{y-u_i}{x} + \right. \\ & \left. \frac{x(y-u_i)}{x^2+(y-u_i)^2} + 2\text{arctg} \frac{y+u_i}{x} \right]; \quad (3.100) \end{aligned}$$

$$\tau_{xy} = \frac{R \cos \alpha}{4\pi} \left\{ \frac{3y^2(x-d) + (x-d)^2}{[y^2 + (x-d)^2]^2} + \right.$$

$$\begin{aligned}
 & + \frac{3y^2(x+d) + (x+d)^3 - 2x(x+d)^2 2xy^2}{[y^2 + (x+d)^2]^2} - K_2 \} + \\
 & + \frac{q}{4\pi} \left[\frac{y^2}{y^2 + (x-a)^2} - \frac{y^2 - 2x(x+a)}{y^2 + (x+a)^2} - \frac{2x^2}{y^2 + x^2} \right] + \\
 & + \frac{\gamma H}{4\pi} \left[\frac{y^2 - 2x(x+a)}{y^2 + (x+a)^2} - \frac{y^2}{y^2 + (x-a)^2} + \frac{1}{2} \ln \frac{y^2 + (x-a)^2}{y^2 + (x+a)^2} \right] + \\
 & + \frac{\beta \gamma H}{4\pi} \left[\frac{y^2}{y^2 + (x-c)^2} - \frac{y^2 - 2x(x+c)}{y^2 + (x+c)^2} - \frac{1}{2} \ln \frac{y^2 + (x-b)^2}{y^2 + (x-c)^2} \right] + \\
 & - \frac{y^2}{y^2 + (x-b)^2} + \frac{y^2 - 2x(x+b)}{y^2 + (x+b)^2} + \frac{1}{2} \ln \frac{y^2 + (x-b)^2}{y^2 + (x+b)^2} \Big] \\
 & + \sum_{i=0}^{i=m} \gamma H \frac{(m-i)}{m} \left[\frac{x^2}{x^2 + (y-u_{i+1})^2} - \frac{x^2}{x^2 + (y-u_{i+1})^2} - \right. \\
 & \quad \left. - \frac{x^2 - 2y(y+u_{i+1})}{x^2 + (y+u_{i+1})^2} - \frac{1}{2} \ln \frac{x^2 + (y-u_{i+1})^2}{x^2 + (y+u_{i+1})^2} + \right. \\
 & \quad \left. + \frac{x^2 - 2y(y+u_i)}{x^2 + (y+u_i)^2} - \frac{1}{2} \ln \frac{x^2 + (y-u_i)^2}{x^2 + (y+u_i)^2} \right], \tag{3.101}
 \end{aligned}$$

where:

$$K_1 = K_2 = 0, \quad \text{if } x \ll d;$$

$$K_1 = \frac{-2ytg\alpha}{y^2 + (x-d)^2}; \quad K_2 = \frac{-2(x-d)tg\alpha}{y^2 + (x-d)^2}, \quad \text{if } x > d$$

$$u_i = \frac{m + iH}{m}.$$

Condition for the destruction of the ceiling. It is essential for rocks to know the direction of tensile stresses at each point of the ceiling. In [9], the lines of the main tensile stress are shown and the results obtained are analyzed.

It was found that at a small step, the line of the highest tensile stresses passes at an angle of 30-35 °, therefore, the destruction of the ceiling occurs at the same angle and is directed towards the exposed obstruction. For $d > 0.2$ m, it runs at an angle greater than 45 °. Based on the assumption that the stress state is the only determining factor in the mechanical state of a given material, it is enough to find a way to compose strength conditions using the values σ_x , σ_y and τ_{xy} : which were found analytically, and σ_{lim} obtained from the tested data. Mohr's theory of strength is currently generally accepted [10]:

$$\sigma_1 = \frac{\sigma_v^p}{\sigma_v^c} \sigma_3 = \sigma_v^p, \quad (3.102)$$

where σ_v^p is the ultimate tensile stress; σ_v^c - ultimate stress of simple compression; σ_1 , σ_3 - highest and lowest principal stresses

Denoting $\frac{\sigma_v^p}{\sigma_v^c}$ through n , on the basis of the formula for principal stresses, the last relation will be reduced to the following form:

$$P = \frac{2\sigma_v^p - (1+n) \sqrt{(\sigma_x - \sigma_y)^2 + 4\tau_{xy}^2}}{(1-n)K}. \quad (3.103)$$

Thus, Mohr's strength criteria allow for the transition of a material from an elastic state to a plastic and brittle fracture without significant deformations, and in all cases, the different resistance of the material to tension and compression is taken into account, i.e., what is the coal mass.

3.7. Establishing critical load on the visor of the securing and supporting craft

According to [11], the calculations were performed for the case of loading the section of the protective-supporting lining through the canopy, taking into account the standard safety factor for the metal structure, in relation to the installation series of the support of the 2OKP70K complex. Calculations of the geometric parameters of the support section were performed in accordance with the KNOP-6-87 algorithm on the Iskra 226 PECVM (Table 3.1). The support loading scheme is shown in Fig. 3.34.

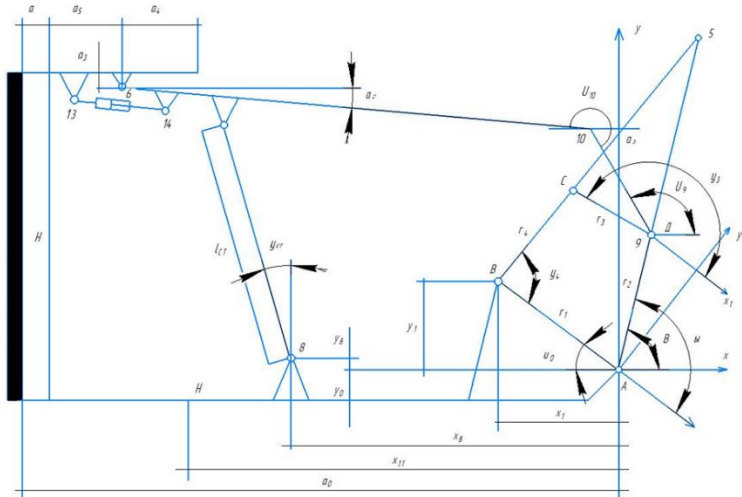

Figure 3.34. Design diagram of the loading of the support section of the protective-supporting type 2OKP70K

Table 3.1. Initial data for calculating geometric parameters

Algorithm symbols	Program symbols	Dimension	Values of quantities	Algorithm symbols	Program symbols	Dimension	Values of quantities
x_1	x_1	M	-0,92	-	1Ø	-	0
y_1	y_1	»	0,35	ξ	E	m	0,0005
x_8	x_8	»	-0,8	b_3b	39	»	0,725
y_8	u_8	»	0,055	$b_3\delta$	B8	»	0,9
d_0	AØ	»	-3,936	L	L9	»	2,77
a_3	A3	»	0,154	x_N	X4	»	-2,77
a_4	A4	»	0,4	y_0	IF	»	-0,16
a_5	A5	»	1	b_1	V7	»	11
Y_1	J 1	»	0,6662	Q _B	O9	kN	0
Y_2	J 2	»	1,897	t_{13}	T3	m	0
Y_3	J 3	»	3,666	h_{13}	N3	»	0
Y_4	J 4	»	1,893	t_{14}	T4	»	0
Y_0	Y 1	»	0,5083	h_{14}	N4	»	0
Y_2	Y 2	»	0,6134	F_{prev}	F	-	0,15
Y_3	Y 3	»	0,6153	Q _{et}	An	kN	1960
r_2	R2	»		C	effort		

r_4	R4	»	1,12		in the	m	0,15
B_0	$B\emptyset$	rad	1,12	P_0	rack	MPa	0,6
	$D\emptyset$	m	0,82	P_1	P_0	»	0,075
			0,0008	P_2	P_1	»	0,15
					P_2		

Table 3.2. Calculation results

Recoverable reservoir thickness, m	Length of the unprotected part of the bottomhole space, m	Vertical component of roof pressure on the canopy, kN	Resistance of the supporting part of the support section, MPa
1	2	4	6
1,600	0,096	975	0,592
1,700	0,108	993	0,599
1,750	0,113	1002	0,602
1,800	0,119	1011	0,605
2,000	0,145	1047	0,616
2,200	0,172	1083	0,626
2,400	0,198	1116	0,635
2,600	0,222	1145	0,642
2,700	0,233	1158	0,645
2,800	0,242	1169	0,647
2,875	0,248	1176	0,649
2,900	0,250	1178	0,649
3,000	0,256	1186	0,651
3,200	0,263	1196	0,652
3,400	0,264	1190	0,650
3,600	0,259	1171	0,641
3,800	0,253	1125	0,619
4,000	0,259	1033	0,566
4,050	0,264	999	0,546

The parameters of the support section obtained by calculation are given in table. 3.2.

However, the established design parameters for the design of the support section do not take into account the deformation characteristics of structural materials.

With the new approach, it is assumed that the roof pressure on the canopy is transmitted by two concentrated forces P , applied at a distance of $0,2l$ and $0,2 \times (L - l)$ from its edges (Fig. 3.35). Then the strut force P_c is determined depending on the magnitude of the resultant pressure forces on the visor, taking into account the friction forces and the curvature of the visor deformation:

$$P_c = 2P \cos \alpha (1 + f \operatorname{tg} \alpha), \quad (3.104)$$

where f is the coefficient of friction, $f = 0.15$; α is the angle of curvature of the visor deformation, degrees; P -critical load, kN, which is determined by the formula:

$$P = \frac{1,3\sigma_v B S^{5/2}}{l^{3/2}} \quad (3.105)$$

where σ_v is the ultimate strength of steel, kg / mm^2 ; B is the width of the visor, mm; S is the thickness of the visor, mm; l is the distance between two concentrated forces applied to the visor, mm.

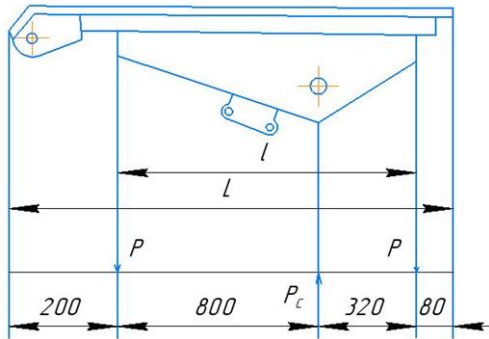

Figure 3.35. Loading scheme of a section through a canopy with two lumped forces

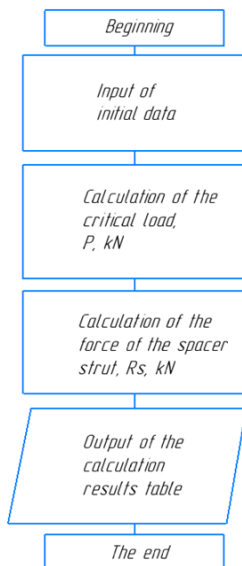

Figure 3.36. Algorithm of the program

3.3. Results of calculating the efforts on the visor

α grade	S , mm	P_c , kN	P_R , kN
1	2	3	4
0,0	50,0	43,29	21,64
1,0	50,0	43,39	21,64
2,0	50,0	43,49	21,64
3,0	50,0	43,57	21,64
4,0	50,0	43,63	21,64
5,0	50,0	43,69	21,64
6,0	50,0	43,73	21,64
8,0	50,0	43,75	21,64
9,0	50,0	43,77	21,64
10,0	50,0	43,76	21,64
11,0	50,0	43,73	21,64
12,0	50,0	43,69	21,64
13,0	50,0	43,64	21,64
14,0	50,0	43,57	21,64
15,0	50,0	43,49	21,64
16,0	50,0	43,40	21,64
17,0	50,0	43,29	21,64
18,0	50,0	43,17	21,64

WAYS OF DEVELOPMENT AND IMPROVEMENT OF POWERED SUPPORTS

19,0	50,0	43,04	21,64
20,0	50,0	42,90	21,64
0,0	100,0	244,86	122,43
1,0	100,0	245,47	122,43
2,0	100,0	245,99	122,43
3,0	100,0	246,45	122,43
4,0	100,0	246,83	122,43
5,0	100,0	247,13	122,43
6,0	100,0	247,36	122,43
7,0	100,0	247,51	122,43
8,0	100,0	247,59	122,43
9,0	100,0	247,59	122,43
10,0	100,0	247,52	122,43
11,0	100,0	247,37	122,43
12,0	100,0	247,15	122,43
13,0	100,0	246,85	122,43
14,0	100,0	246,47	122,43
15,0	100,0	246,02	122,43
16,0	100,0	245,50	122,43
17,0	100,0	244,90	122,43
18,0	100,0	244,23	122,43
19,0	100,0	243,48	122,43
20,0	100,0	242,66	122,43
0,0	150,0	674,76	337,38
1,0	150,0	676,42	337,38
2,0	150,0	677,88	337,38
3,0	150,0	679,13	337,38
4,0	150,0	680,18	337,38
5,0	150,0	681,01	337,38
6,0	150,0	681,64	337,38
7,0	150,0	682,07	337,38
8,0	150,0	682,28	337,38
9,0	150,0	682,29	337,38
10,0	150,0	682,08	337,38
11,0	150,0	681,68	337,38
12,0	150,0	681,06	337,38
13,0	150,0	680,23	337,38
14,0	150,0	679,20	337,38
15,0	150,0	677,96	337,38
16,0	150,0	676,52	337,38
17,0	150,0	674,87	337,38
18,0	150,0	673,01	337,38
19,0	150,0	670,95	337,38

WAYS OF DEVELOPMENT AND IMPROVEMENT OF POWERED SUPPORTS

20,0	150,0	668,68	337,38
0,0	200,0	1385,15	692,57
1,0	200,0	1388,56	692,57
2,0	200,0	1391,55	692,57
3,0	200,0	1394,12	692,57
4,0	200,0	1396,27	692,57
5,0	200,0	1397,99	692,57
6,0	200,0	1399,28	692,57
7,0	200,0	1400,14	692,57
8,0	200,0	1400,58	692,57
9,0	200,0	1400,60	692,57
10,0	200,0	1400,18	692,57
11,0	200,0	1399,34	692,57
12,0	200,0	1398,08	692,57
13,0	200,0	1396,38	692,57
14,0	200,0	1394,27	692,57
15,0	200,0	1391,73	692,57
16,0	200,0	1388,76	692,57
17,0	200,0	1385,37	692,57
18,0	200,0	1381,56	692,57
19,0	200,0	1377,33	692,57
20,0	200,0	1372,68	692,57
0,0	250,0	2419,75	1209,88
1,0	250,0	2425,72	1209,88
2,0	250,0	2430,95	1209,88
3,0	250,0	2435,43	1209,88
4,0	250,0	2439,18	1209,88
5,0	250,0	2442,18	1209,88
6,0	250,0	2444,44	1209,88
7,0	250,0	2445,95	1209,88
8,0	250,0	2446,72	1209,88
9,0	250,0	2446,74	1209,88
10,0	250,0	2446,02	1209,88
11,0	250,0	2444,55	1209,88
12,0	250,0	2442,34	1209,88
13,0	250,0	2439,38	1209,88
14,0	250,0	2435,68	1209,88
15,0	250,0	2431,24	1209,88
16,0	250,0	2426,06	1209,88
17,0	250,0	2420,14	1209,88
18,0	250,0	2413,48	1209,88
19,0	250,0	2406,09	1209,88
20,0	250,0	2397,96	1209,88

The CREP, PAS program is built in an interactive mode and allows you to quickly make adjustments to the calculation. It is written in the TURBOPASRAL language (version No. 6) for a 1BM PC / XT personal computer. The program algorithm is shown in Fig. 3.36. The calculation results are shown in table. 3.3 and on the printing device (printer). The calculation is valid for a canopy structure with a rectangular cross-section.

```
program grep;
uses Printer;
var Pk, sigms, s, b, f, pc, I, alf, alf1:real;
begin
writeln (Ist, ,, Calculation of the force on the visor ");
writeln („Enter the yield strength for steel ");
readln (sigms);
writeln (Ist, ,, Yield Strength for Steel =", sigms:6:2);
writeln („Enter sheet width ");
readln (b);
writeln (Ist, ,, Sheet width =", b:6:2);
writeln („Enter the shoulder of the action of force ");
readln (I);
writeln (Ist, ,, Shoulder of Force Action ==", I:8:2);
writeln (Ist);
writeln (Ist, '
writeln (Ist, alf, hail s, mm pc, kN pk, kN');
writeln (Ist, ');
writeln (Ist, '
');
5=0; f:=0,15;
repeat
s:=s+50; alf:=-1
repeat
alf:=alf+1; alf1:=alf/180*p1;
pk:=1.3*sigms*b*SQRT(S*S*S*S*S)/SQRT (LXL*
*L)/ 10000;
pc:=2>pk>cos(alf1)>k(1+f*sin(alf1)/cos(alf1));
writeln (Ist '!', alf:5:1. '!', s:5:1, '!', pc:6:2, '!', pk:9:2, '!');
until alf==20
until s=250;
writeln (Ist, ');
end.
```

4. HYDRAULIC SYSTEMS OF POWERED SUPPORTS

4.1 General information

All powered roof supports are currently performed, as a rule, hydraulically, based on the use of a hydraulic drive of the "constant feed pump - hydraulic cylinder system" type.

Hydraulic drive systems of the "pump - system of hydraulic cylinders" type in powered roof supports are characterized by the following most important features.

1. Powered support has a relatively long length of hydraulic communications (in some cases, over 200 m), which predetermines the presence in the hydraulic drive system of a large number of hydraulic props (from about 50 to 1000 pieces) and hydraulic jacks (from about 50 to 300 pieces) with a corresponding large number of safety and unloading valves, distributors, flexible and rigid hydraulic lines along the entire length of the longwall with a large number of connecting fittings and sealing elements.

2. The working fluid is fed to the hydraulic props system, hydraulic jacks for movement and auxiliary hydraulic cylinders from a pumping station, usually controlled remotely and located on the lower haulage drift or in a clearing.

3. There is a sectional structure of powered support with a set of hydraulic props, hydraulic jacks for movement and other hydraulic cylinders, repeated in each section, with a set of control and distribution equipment.

4. When moving the support sections and the face conveyor, a significant volume of working fluid circulates in the hydraulic drive system (up to 600 800 liters).

5. The hydraulic struts supporting the roof in the working face have a significant initial thrust force. In this regard, in the hydraulic drive system for powering the hydraulic props, the operating pressure along the pressure line is 16–20 MPa, with a tendency to increase in the coming years to 32 MPa. After the initial expansion of the hydraulic struts, their hydraulic system is disconnected from the pressure line and a closed hydraulic system is formed, in which, under the influence of monotonous lowering of the roof rocks at an average speed of about 3 mm / h, the pressure rises until the safety valve is triggered, usually equal to 30–80 MPa.

6. All units of the hydraulic drive system of the hydraulic rack have a high degree of tightness and reliability in operation, especially the sealing of hydraulic props, safety and unloading valves, since the failure of any of these elements or the appearance of microleaks leads to the loss of working resistance by the hydraulic props, which causes dangerous situations in

working space due to the violation of the integrity of the roof rocks and the possibility of its collapse. Taking into account the complexity and laboriousness of the installation and dismantling of powered support and repairs in the face of a working face, the hydraulic drive system must reliably ensure the development without repair and replacement of elements of the entire cut-off excavation field (column) of lava for the entire length.

7. The hydraulic drive system, like all its hydraulic units, operates in a mine methane-air atmosphere with high humidity and dusty air, in a cramped working space, which makes it difficult to access the hydraulic units and their inspection. As a rule, under these conditions, hydraulic units cannot be repaired in a working face, therefore, it is required to ensure the possibility of easy replacement during repair shifts of individual failed hydraulic units during the operation of powered supports.

8. Manual control of the support sections for safety purposes is carried out by the operator remotely from an adjacent section or from a control panel placed on the drift. Management of the support sections consists in repeating such basic commands as "Unloading the legs", "Moving the section", "Spreading the legs", "Moving the face conveyor". In addition to these operational commands, there are commands associated with ensuring the directed and specified positions of the sections in space (commands associated with the stability system of the sections, adjusting their directional position relative to the face conveyor, etc.).

9. In hydraulic drive systems, piston pumps of constant feed are used, equipped with feed regulators or automatic unloading machines in combination with hydropneumatic regulators. Water-oil emulsions are used as a working fluid.

The required flow of the pumping station is in the range of 35–120 l / min.

The given features of the hydraulic drive of powered supports determine the specificity of circuit and design solutions inherent in a specific hydraulic drive system of the "pump hydraulic cylinders" type.

4.2. Classification of sectional hydraulic diagrams

Regardless of the design, the method of interaction with the roof and other features of powered roof supports, the systems of their volumetric hydraulic drives have the same functional purpose, therefore, the divisions and categories of the classification of powered supports are not decisive for constructing the classification of their hydraulic systems. It is advisable to consider the classification not of the entire hydraulic system as a whole, since it can only be of a general nature, but of its individual sections, which were

mentioned above. In this case, a more specific systematization of their structure and features is possible.

The above classification of hydraulic systems of the support sections is based on the following signs, by which one can judge the features of their structure.

Control method. Manually operated roof supports are currently the most widespread, however, the transition to automated control of powered roof supports is expanding.

Since the hydraulic circuit depends on the control method, the classification according to this criterion seems to be important and allows us to divide all the considered circuits into two groups: hydraulic systems with manual control and hydraulic systems with elements of automatic and remote control.

In automatic hydraulic systems, a sequence of work steps is performed and repeated after activation until the operator stops working. This automatic control cycle is called closed. It is very difficult to implement it in powered supports at the modern level due to a number of reasons not related to the hydraulic drive (including due to the imperfection of the supports themselves).

To control powered roof support, semi-automatic systems are created, in which, in one combination or another, remote control and automation elements are used.

For example, when the section is moving, unloading, shifting and spacer are carried out automatically, and the command to perform these operations is given remotely from the control section or the central control panel. Remote control is a special case of automatic, therefore, hydraulic circuits with such types of control are classified in the same group.

The number of working operations performed by hydraulic jacks of movement. On this basis, all schemes can be divided into three groups: single-stage, double-stage and mixed.

In the latter, there are two types of hydraulic jacks that perform one or two working operations. The first group mainly includes the diagrams of hydraulic systems of complete supports, the second and third - the diagrams of hydraulic systems of the sections of the aggregate supports.

The order of performing the elements of working operations. Differing schemes of hydraulic systems, which provide for sequential and sequential-parallel execution of all elements of working operations.

Type of hydraulic lock control. In the considered schemes, there is manual and hydraulic control of the hydraulic lock. The latter is typical for newer support designs.

The number of racks or their groups that have separate control for spreading and unloading. There are one-, two- and very rarely three-group schemes.

The given classification features sufficiently characterize the sectional hydraulic system diagram. To simplify the diagram, more detailed subdivisions have been omitted to account for finer differences. For example, one could take into account the number of racks in sections, types of valves, type of energy carrier used for automatic control, etc.

4.3. Principles of constructing a sectional fluid diagram powered supports

The operation of the powered support hydraulic drive system is determined by its hydraulic scheme, which is the main technical document for the hydraulic system of the machine and allows you to quickly establish the number and type of hydraulic components, their mutual actions, and also show the operation of the entire hydraulic support system as a whole.

The most convenient for studying the hydraulic support system is the hydraulic system of its linear section (set), which includes hydraulic props, hydraulic jacks for movement and auxiliary control devices and lines.

The cycle of operations performed by powered support is mainly determined by its purpose and slightly depends on the design. The hydraulic drive systems of all powered roof supports are designed for the same operations. The analysis shows that the schematic diagrams of hydraulic systems are different even for powered supports operating in the same mining and geological conditions. This difference is due to both the design features of the support section and the adopted technological scheme of the entire complex. Design features and control methods for distribution equipment also make a difference in the hydraulic circuits of powered supports.

The full cycle of working operations performed by powered support consists of the following elements:

1. Support under load. In the closed volume of the piston cavity of the hydraulic props, the pressure is limited by a rack-mount safety valve. The hydraulic lock is closed. All control devices of the hydraulic drive of the section are in the neutral position. Conventionally, this position of the support can be considered the initial one. In the initial position, most often the sectional hydraulic network, as well as the cavities of the hydraulic jacks of movement, are connected to the drain when the pumping station is turned on. But in some supports (AKZ unit, KGD2 support, etc.), in the initial position of the support, pressure is supplied to the hydraulic lock of the props.

2. From the initial position, two operations can be performed in the support: the movement of the conveyor or the basic support beam and the movement of the support sections. These operations are carried out with the help of hydraulic jacks of movement, however, the functions of the latter, as the analysis shows, are not the same in different supports. So, sectional hydraulic jacks in most modular supports are used to perform these two operations, and in complete supports - only for moving the support sets themselves:

Complete and some powered roof supports are most often constructed from two sections. For example, 2M81K support consists of two-post sections. The upper floors of all sections are rigidly connected into one common base system. In each section, a hydraulic jack is located between two adjacent floors. The sections are moved by two adjacent hydraulic jacks simultaneously. Some sections move when fluid is supplied to the piston cavities of hydraulic jacks, others - to the rod ones. The order of movement is as follows: first, the sections are moved through one (for example, two odd ones), then the section between them (even). Unlike complete supports, both racks have separate control (for which a distribution block with a hydraulic lock is installed on each rack) and can be unloaded or expanded independently of each other.

The hydraulic jack cavities are locked with a double hydraulic lock to prevent spontaneous movement of the cylinder or piston of the jack when extending adjacent sections. For the movement of each section, the scheme provides for eight switchings of the working links of the distributors.

All aggregate supports are referred to sectional roof supports. This group also includes complete roof supports with telescopic sections, since they do not differ from aggregate supports in terms of the operation scheme.

The main design feature of modular supports is the presence of a common base system. Most often, such a system is a conveyor. This feature largely determines the design of both the support itself and the sectional hydraulic system.

Aggregate support consists of single or multi-post sections. Each of them is connected to a conveyor (or other basic structure) using a hydraulic jack. When moving, the sections are pulled up to the support base, which perceives the forces developed by the hydraulic jack. In turn, the support sections are the support when moving the conveyor or other support base. Thus, as in complete supports, the movement of the entire aggregate support is carried out due to the relative movement of groups of its elements. In most of the supports under consideration, the conveyor moves when the hydraulic jack is extended, and the sections are pulled up when it is reduced. The movement of the base system is associated with the supply of fluid to the

piston cavities of the hydraulic jacks, and of the sections - to the rod ones, with the exception of lining of the IMK type.

The scheme of operation of the supports under consideration is as follows:

1. Starting position. In modular supports, the starting position is the same as in complete ones. It usually precedes the start of any locomotion operation.

2. Moving the base system, the props remain under load. The working fluid enters the piston cavity of the jack. There are three ways of moving the entire basic system: a) by jacks of all sections at the same time to the full stroke of hydraulic jacks; b) by all jacks of the sections simultaneously for a part of the hydraulic jacks stroke, corresponding to the size of the grip of the excavating machine (plow); movement at full speed of the hydraulic jack in this case is carried out in several stages; c) alternate movement of the hydraulic jacks on the course of the sections of the base system, which in this case is structurally presented as a flexible system that allows relative displacements of individual links.

3. Moving the support section. This operation includes three stages:

a) unloading the hydraulic props of the sections from pressure or reducing the pressure in them to a value at which movement is possible; b) supply of fluid to the rod, and in the supports of the IMK c type to the piston cavity of the hydraulic jack: in this case, the section freed from the load moves one step of the movement;

c) the spacer of the struts of the moved section.

In the supports M87D, OKP, etc., these stages are performed sequentially and three control commands are required to complete the entire operation.

When moving the support sections M87AE, E87DGA, etc., one control command is required to simultaneously perform the first two stages of this operation. Combining the unloading of the racks with the movement of the sections is also a feature of all supports, in the sectional hydraulic drive of which fluid is provided to the hydraulic locks of the racks through the cavities of the hydraulic jacks.

The spacing of the section props completes all operations in the support, brings the sections to their original position, after which the cycle of operations is repeated.

In the schemes of sectional hydraulic systems of the supports under consideration, the following external differences can be noted.

1. The number of racks in sections can be from one to six.
2. Hydraulic props are of one-sided and double-sided action.

3. Most often, a column-mounted hydraulic unit is provided for each hydraulic support support. The Donbass lining uses one block per group of props, located in the section parallel to the bottom.

4. Simultaneous unloading and spacing of all section props is carried out in the Donbass supports. In other supports, the racks are unloaded in several groups or each separately.

5. Operations of movement in the majority of aggregate supports are carried out with one hydraulic jack.

6. In the M87D, M87E supports and the AZ unit, the base movement operation is controlled from the central control panel. Other supports use manual control of distributors in each section.

7. Operation of the movement of sections in most supports is controlled manually. The exception is the support of the AKZ unit and the support M87AE, M87DGA with remote control and automated control elements.

8. The number of hydraulic valves in the modular supports is different. In the known structures of supports, from one to four hydraulic valves are found.

9. The most significant for the principle sectional hydraulic circuit, as in the supports of the first group, is the difference in the distributor circuit, the number of distributors and the required number of control commands during operation.

In the sectional hydraulic drive of many supports, in addition to the main movement jacks, auxiliary ones are also provided: in the Donbass support - jacks for extending the upper support console, in the 2M81K support - hydropaths for controlling the support in the seam, etc.

In addition to the main ones, most hydraulic systems of powered supports provide for a number of auxiliary operations associated with installation, repair or emergency work in the support. There are three main operations.

1. Pulling the conveyor or base away from the bottom (in case of jamming of the breaker, blockages, etc.). To perform this operation, it is necessary to turn on the corresponding cavities of the jacks for movement in all sections or part of them, without unloading the support racks in the sections. In some supports, locking devices for hydraulic pushers of hydraulic locks are provided, in others, the piston cavity of the rack is locked with a valve. Sometimes a special position is used in the valve.

2. Forced lowering of the ceiling (in case of breakdowns, stitching of the lower supports, replacement of the post valve body, etc.). Most often, this operation provides for manual control of the hydraulic lock while simultaneously supplying pressure to the rod cavity of the rack. The latter is

achieved either by switching the distributor (for example, in the M87D support), or by remounting special valves in the distribution block (for example, in the AKZ support).

3. Disconnection of the section from the working hydraulic lines. On the pressure lines, shut-off valves are used for this. The cavities of the hydraulic jacks are connected to the drain, and the movement of this section is carried out by the base or the conveyor. The hydraulic props in the section are also pressure-relieved; their cavities are either connected to the drain line, or locked.

Analysis shows that the need to perform auxiliary operations in the support is most often caused by the imperfection of the structure of the support itself, improper operation, inconsistency of this support structure with mining and geological conditions and other reasons.

Auxiliary operations in the section's hydraulic drive circuit complicate and increase its cost, since the amount of hydraulic equipment increases, which is often not used at all during operation.

Consideration of the construction and features, as well as comparison of the given sectional hydraulic circuits, show the following:

1. In general, the hydraulic circuits of the powered support sections are not complicated, they use simple control devices, and the number of working operations is small.

2. Improvement of the hydraulic system is carried out at the expense of both the use of more elaborated and corresponding to the specifics of the lining of the structures of individual elements, and the simplification of the distributors, the number of control commands, the refusal of manual control of the hydraulic lock.

3. The great variety in the schemes of hydraulic systems is explained not only by the qualitative difference in the structures of supports or the operations performed by them, but to a large extent by the lack of a unified technical approach in the circuit solutions for the same type of structures of powered supports. For example, there is no consensus on the advisability of using the cavities of the hydraulic jack of movement in the hydraulic circuits of the fluid flow into the hydraulic prop. This scheme has advantages (reduction in the number of flexible sleeves) and disadvantages (interconnection of two elements of operations). With manual control, the disadvantages can be compensated for by the introduction of additional control commands and valves, and with automation, such a scheme will require a more complex control scheme.

At present, there is no sufficient justification for creating a backwater in hydraulic props when moving sections and the scope of such schemes has not been established.

The solution of these issues is possible on the basis of special experimental and economic research.

4.4 Optimization of the hydraulic circuit structure powered supports

As a criterion for optimizing powered support, it is advisable to take the indicator that most reflects productivity. This indicator is the duration of the cycle of the powered support T_c . The productivity of the complex depends on T_c . With a decrease in the time spent on the support cycle, the likelihood of an increase in the number of cycles per shift and an increase in productivity increases. The duration of the cycle of the powered support T_c is the sum of the time spent on performing all working operations, mainly in the hydraulic system, therefore this indicator most reflects the influence of the features of the hydraulic drive on the economic efficiency of the complex and is the most acceptable criterion of quality or optimality for evaluating options at all stages selection of optimal hydraulic drive solutions.

The choice of T_c as an optimization criterion also has the advantage that it allows one to take into account the probabilistic nature of the processes occurring in the “mechanized complex — host rocks” system. During the operation of the support and the complex, the duration of the cycle and the duration of working operations in the sections will be variable values that obey the random laws of change both in different sections and in different cycles, despite the constancy of the basic set of conditions (i.e., design parameters). On the basis of generalization of the results of time-keeping observations of the operation of powered supports, the parameters of the random laws of change in T_c were determined and taken into account in the optimization calculations.

In general terms, the value of T_c can be expressed by the dependence:

$$T_c = T_c + T_k + T_{o,m} + T_{o,k} + T_{p,n} + T_{x,x} + T_n \quad (4.1)$$

where T_c is the total duration of movements of all sections;

T_k - the time of the conveyor movement not combined with the movement of the sections

$T_{o,m}$ — total stopping time associated with a decrease in speed and downtime of the excavating machine;

$T_{o,k}$ - the total stopping time associated with a decrease in speed or downtime when moving the conveyor;

$T_{p,n}$ - time spent on preparation for the next cycle (preparation of niches, reassembly of the harvester, etc.);

$T_{x.x}$ — the time spent on idling of the combine in case of one-sided operation;

T_n — time taken from the beginning of the cycle to the beginning of the first movement of the sections.

In expression (4.1), two groups of terms can be distinguished: the time spent, which depends on the work of the powered support, and the time that does not depend on it. The first group includes the quantities T_c , T_k , $T_{o.k}$, to the second - the rest. Thus, the cycle of the powered support hydraulic drive is expressed by the dependence:

$$T_{c.g} = T_c + T_k + T_{o.k} \quad (4.2)$$

The comparison criteria defined by expressions (4.1) and (4.2) are used at various stages of the optimal calculation. When establishing the sequence of operation of hydraulic motors, which reflects the scheme of operation of the entire complex, the T_c criterion is used, when optimizing the structure of the hydraulic system, the $T_{c.g}$ criterion or components of the $T_{c.g}$. The goal of optimization is to find a solution that meets the minimum value of the comparison criterion.

At the stage of identifying the optimal sequence of operation of hydraulic motors, it is also necessary to take into account the limitation:

$$T_{1m} \geq T_{2n} \quad (4.3)$$

where t_{1m} is the duration of coal extraction in the area before the t -th section; t_{2n} is the total duration of all operations to move the n th section or retractable top in this section.

The distance between the sections m and n is determined by the permissible size of the unsecured roof area. This limitation reflects the degree to which the attachment speed matches the excavation speed. Indirectly, it also reflects the influence of the work of the hydraulic drive of the powered support on the productivity of the complex. In addition, this limitation is associated with ensuring the safety and reliability of work in the support.

The numerical determination of the quantities that make up T_c and $T_{c.g}$ is associated with difficulties. In addition to cumbersome calculations, it is necessary to know all the parameters of the hydraulic drive and its elements, the values of the acting loads and the laws of their change, which is difficult, especially at the design stage. With a large number of possible alternatives, these difficulties lead to insoluble problems; therefore, it is advisable to reduce the number of optimized options based on preliminary qualitative logical analysis.

The essence of this analysis is as follows. For each solution, the comparison criterion is written in general form as a function of some arguments. Arguments with the same meaning are denoted by the same symbols. At each stage of the optimization calculation (in each problem), its own arguments are accepted. For example, at the stage of identifying the optimal scheme of the hydraulic drive operation, it is advisable to take the duration of the main working operations in the support sections as arguments, while determining the optimal connections in the hydraulic system - the speed of the hydraulic elements and the duration of the elements of working operations.

Further, we conventionally assume that the solutions refer to the same structural types of supports intended for operation in mountainous conditions of the same complexity class, and when optimizing connections in the hydraulic system, we take constant parameters of hydraulic motors and a source of hydraulic energy. This assumption allows, in the subsequent comparative analysis of the formulas of the comparison criteria, to consider the values indicated by the same symbols as equal.

Comparison of the obtained formulas allows evaluating the considered solutions and discarding those for which the value of the optimization criterion is obviously higher. For example, let's compare the following two solutions: $D_1 = \{\text{shuttle recess; two-wave movement of sections; wave movement of the base; the hydraulic jack of movement in the initial position is extended; all hydraulic jacks are used to move the conveyor}\}$; $D_2 = \{\text{shuttle recess; two-wave movement of sections; frontal movement of the base; the hydraulic jack of movement in the initial position is extended; half of the hydraulic jacks are used to move the conveyor (through one section)}\}$.

The diagrams corresponding to these solutions are shown in Fig. 4.1 and 4.2.

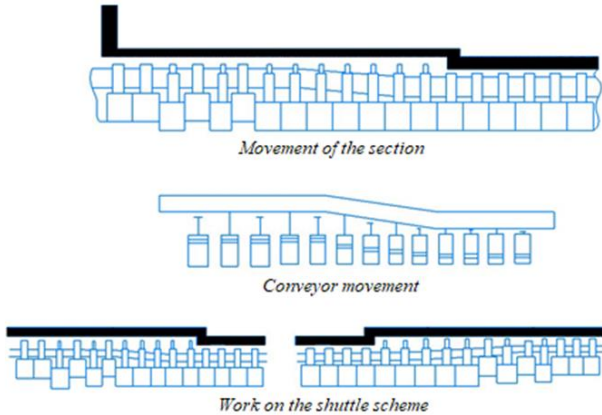

Figure 4.1. The scheme of work of powered support with wave conveyor movement

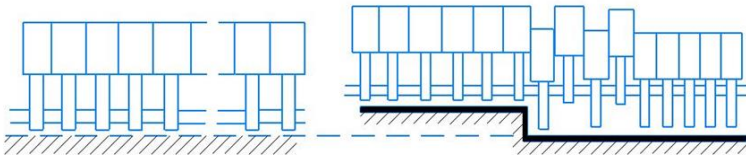

Figure 4.2. The scheme of powered support with frontal movement of the conveyor

To draw up formulas for comparison criteria, the work cycle of the support is viewed sequentially from the first to the last (M -th) section and the time costs, taking into account the combination of individual operations, are summed up:

$$T_{D_1} = \Delta t + \alpha \sum_{m=1}^M t_{2m} + 0,5 \sum_{m=M_1}^{M_2} t_{3m} + T_k ; \quad (4.4)$$

$$T_{D_1} = \Delta t + \alpha \sum_{m=1}^M t_{2m} + 0,5 \sum_{m=1}^M t_{3m} + T_k$$

where Δt is the time from the start of excavation to the start of movement of the first section; t_{2m} , t_{3m} - time for movement of a section and a conveyor in one section; M is the number of all support sections; $M_2 - M_1$ - the number of sections at the conveyor wavelength; $M - M_2$ - the number of

sections along the length of the combine body; α - coefficient of combination of section extension operations; T_k - duration of end operations.

Comparison of T_{D_1} and T_{D_2} shows that T_{D_2} is greater, since:

$$T_{D_2} - T_{D_1} = 0,5 \sum_{m=1}^M t_{3m} - \sum_{m=M_1}^{M_2} t_{3m} - \sum_{m=M_2}^M t_{3m} > 0 \quad (4.5)$$

$$M - M_1 \ll 0,5M.$$

The final optimal solution is selected based on the numerical calculation of comparison criteria for the remaining options. The problem is solved under the following initial positions and constraints: only solutions are considered for complexes with aggregate supports and one base; examines the relationship of mechanisms and working operations in one cycle; conditionally, end operations are not taken; the same hydraulic jacks are used to move the sections and the base; when moving the base, the hydraulic jacks move apart; the section cannot be moved a fraction of the hydraulic jack stroke; when several hydraulic jacks are connected in parallel, they work synchronously; the parameters of the pumping station, hydraulic cylinders and hydraulic system elements are taken constant in all variants of the schemes; all operations in time are combined within the maximum allowed by this scheme.

In formula (4.4), the comparison criteria for the hydraulic drive operation schemes shown in Fig. 4.1. and 4.2 are the durations in each section of the conveyor travel operations t_{3m} and section t_{2m} . In this case, the time of expansion and unloading of the section racks is included in the value of t_{2m} as a component. The values of these quantities depend on the schematic diagram of the hydraulic drive and the parameters of its elements. They can be taken as comparison criteria at the stage of optimal solutions of the concept of the section and the entire hydraulic drive of the powered support.

In general, the duration of any working operation in powered support can be expressed by the following relationship:

$$t_{im} = t_{iy} + t_p + \sum_{k=1}^k Z_k (\delta_k + t_k) + \sum_{j=1}^j (t_{oi} C_{im}) j \quad (4.6)$$

where im is the index of the operation and section; t_y - time to prepare for management; t_p — the time for the operator to move to the support; k is the number of control hydraulic elements; Z is the number of switchings of control hydraulic elements;

δ_k - speed of action of a hydraulic element or a line; t_k - time of switching the hydraulic valve; I is the number of executive hydraulic motors;

t_{oi} — estimated operating time of hydraulic motors during operations; C_{im} is a coefficient that takes into account the change in the estimated speed of movement of the working link of the hydraulic motor in different sections during different operations.

Let us consider expression (4.6) in more detail. The values included in it reflect the following factors: the adopted control scheme — t_y, t_p ; design and schematic features of the hydraulic system - δ_k, Z_k, t_k ; parameters of the pumping unit, pipelines, hydraulic motors - t_{oi} ; features of the power mode of operation, transient processes in the system, etc. — C_{im} .

The specific weight of these values in the total amount of time spent on a working operation is different. The main thing is the operating time of the hydraulic motor when performing operations t_{oi} .

The execution time of a working operation t_{oi} is determined by methods widely known in the general theory of hydraulic drive, and depends on the magnitude and nature of the load on the executive body R_i , the reduced mass of the hydromechanical system M_{pr} , the reduced coefficient of local and linear losses β_{pr} , the parameters of the hydraulic cylinder P, S, α , pressure in the pressure head and drain lines P_h, P_{sl} . The rest of the terms included in formula (4.6) can make up a greater or lesser part of the cycle. For example, if it is required to move the upper runner after the passage of the excavating machine moving at a speed of 6 and 10 m / min, then with a step of arranging sections of 1 m, this operation will require: $i_v = 60/6 = 10$ s; $t_v = 60/10 = 6$ s.

If the hydropower is supplied to the hydraulic cylinder of the upper strut through the channel of the hydraulic valve, which is switched during the movement of the excavating machine, then:

$$T_v = \delta_1 + \delta_2 + t_1 + t_{0,v}, \quad (4.7)$$

where δ_1 is the speed of the hydraulic valve; δ_2 is the speed of the pressure line; t_1 is the switching time.

When testing powered roof supports, it was obtained:

$\delta_1 \approx 0,2 - 0,3$ c; $\delta_2 \approx 1 - 0,5$ c; $t_1 \approx 0,1 - 0,07$ c (at switching stroke 10 mm); $\delta_1 + \delta_2 + t_1 = 0,2 + 0,5 + 0,1 = 0,8$ c, that at a fastening speed of 6 m / min it will be 8% (0.8 / 10), and at a fastening speed of 10 m / min - 13% of the total time spent on this operation in one section.

Optimal hydraulic schemes for each type of powered roof supports must be created using solutions that meet the selected optimality criteria, i.e., the minimum time spent on performing each operation in the hydraulic system. These solutions are as follows: the use of separate pressure mains for parallel operations; performing the operation "Spacer" at the initial position of the distributor; reducing the volume of the working cavities of hydraulic

motors while increasing the working pressure in the hydraulic system; remote and automatic activation of operations; hydraulic and mechanical switching of power distributors; electrical, mechanical and manual (for remote control of working operations from the panel on the adjacent section) control of command valves.

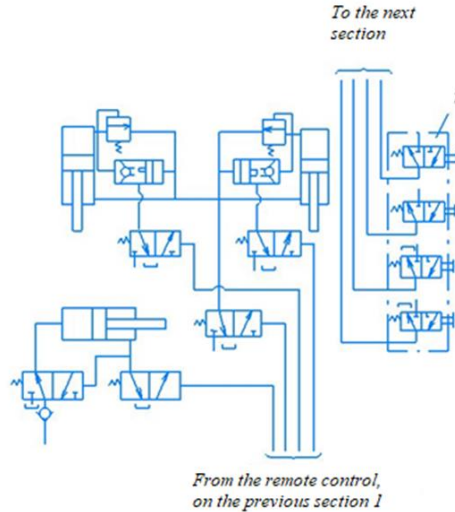

Figure 4.3. A variant of the hydraulic system diagram of the section for support of the M87 type using the optimal (1 - section control panel)

As an example of the use of these solutions in the scheme of a two-column section (or a section with two rows of columns with common control), a hydraulic circuit is shown (Fig. 4.3). Such a scheme can be applied to supports of the M87 type.

Let us compare the well-known hydraulic systems of supports of the M87 type (M87E, M87A) in terms of the time spent on the operation of moving the section (t_{2m}) with the diagram in Fig. 4.3, which uses solutions that meet the accepted criteria of optimality. Let us agree that the time spent on thrusting (t_p) and unloading (t_c) of the struts is, respectively, the same in all compared schemes, and t_o is the time of movement of the section (reduction of the hydraulic jack).

In the M87D support section, the working fluid flow is distributed by a multi-position power distributor

$$\begin{aligned}
 t_{2m} &= \underbrace{t_{11} + \delta_{11} + t_c + \delta_{31}}_{\text{thrust}} + \underbrace{t_{11} + \delta_{11} + t_0 + \delta_{31}}_{\text{shifting}} + t_{11} + t_{11} \\
 &\quad + \underbrace{\delta_{11} + \delta_{31} + t_p}_{\text{shifting}} = \\
 &= 4t_{11} + 3\delta_1 + 3\delta_{31} + t_c + t_p + t_0 \quad (4.8)
 \end{aligned}$$

The M87A support uses a manually operated multi-position power valve, but the section moves in its original position, without switching. For this operation, when it is performed in automatic mode, the second power distributor of the circuit is used, controlled from the command distributor with an electromagnet:

$$\begin{aligned}
 t_{2m} &= \underbrace{t_{y4} + \delta_{21} + t_{22} + \delta_{12} + \delta_{11} + \delta_{31} + t_c + t_0}_{\text{unloading and moving}} + \\
 &\quad + t_{y4} + \delta_{21} + \underbrace{t_{22} + \delta_{12} + \delta_{11} + t_p + \delta_{31}}_{\text{thrust}} = 2t_{y4} + \quad (4.9) \\
 &\quad + 2\delta_{21} + 2t_{22} + 2\delta_{12} + 2\delta_{11} + 2\delta_{31} + t_c + t_p + t_0
 \end{aligned}$$

For the circuit in Fig. 4.3 we obtain (assuming that the switching of the command valves in the adjacent section is electrical and the flow rate in the control lines is sufficient for the simultaneous switching of three power valves):

$$\begin{aligned}
 t_{2m} &= \underbrace{t_{y4} + \delta_{21} + t_{23} + \delta_{23} + t_c + t_0 + t_{31}}_{\text{unloading and moving}} + \\
 &\quad + \underbrace{t_{y4} + \delta_{21} + t_{23} + \delta_{13} + \delta_{32} + t_p}_{\text{thrust}} = 2t_{y4} + 2\delta_{21} + \quad (4.10) \\
 &\quad + 2t_{23} + 2\delta_{13} + \delta_{31} + \delta_{32} + t_c + t_p + t_0
 \end{aligned}$$

In formulas (4.8) - (4.10), the following designations are adopted:
 t_{1i} - switching time of the power distributor with manual control;
 i - index, number of valves or lines; t_{2i} - switching time of the power distributor during hydraulic control; t_{3i} - switching time of the power

distributor during mechanical control; δ_{li} - power distributor speed, δ_{2i} - switching time of the power distributor; δ_{3i} - power line speed;

$t_{y1}, t_{y2}, t_{y3}, t_{y4}$ are the switching times of the control valve for manual, hydraulic, mechanical and electrical control, respectively; t_y - additional loss of time when controlling from an adjacent section.

According to the measurements, the following values of the quantities included in the above expressions can be taken:

$$t_{11} = 1 - 3 \text{ c}; \delta_{11} \approx 0,3 - 0,4 \text{ c}; \delta_{31} = 0,1 - 5 \text{ c}; \delta_{32} = 1 - 2 \text{ c}; t_{y4} + \delta_{21} = 0,1 - 0,15 \text{ c}; t_{22} + \delta_{12} = 0,2 - 0,3 \text{ c}; t_{23} + \delta_{13} = 0,2 - 0,3 \text{ c}; .$$

Based on the results of mine observations of the operation of the M87A support, the average values of $t_{2m} = 18$ s, and the minimum - 14 s, were obtained. Assuming that the time consumption $t_c + t_o + t_p$ in all compared schemes is the same as in the M87A support, we get:

for roof support M87E

$$t_{2m} = 16,55 + (18 - 6,5) = 28,05 \text{ c}; \quad (4.11)$$

for roof support M87A

$$t_{2m} = 18 \text{ c} = 6,5 + t_c + t_o + t_p; \quad (4.12)$$

for the circuit in fig. 4.3

$$t_{2m} = 4,8 + (18 - 6,5) = 16,3 \text{ c}. \quad (4.13)$$

The above calculation shows that in the optimal hydraulic circuit, the time spent on moving the section can be reduced by more than 70% compared to the M87E circuit and by 10% compared to the M87A circuit. It should be borne in mind that some of the recommended solutions are used in the hydraulic circuit of the M87A support - a strut in the initial position of the valve, electric control of the command valve, hydraulic switching of the power valve.

4.5. Hydraulic circuits of powered supports

Hydraulic diagram of powered support of KMT type. Powered roof support of the KMT type has the following features: a four-post support section with two hydraulic jacks for movement; charged scheme of movement of the support sections, with the movement of the sections sequentially after the combine, with remote control from the adjacent (overlying) section; frontal extension of the conveyor after the coal strip has been removed by the combine; the presence of a stability system with one hydraulic cylinder; use of valve type distributors with separate handles to control the front and rear struts and hydraulic travel jacks.

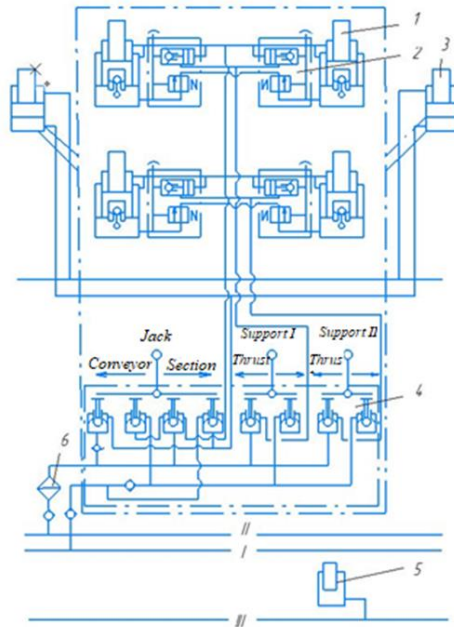

Figure 4.4. Hydraulic diagram of MT powered support:

- 1 - hydraulic support; 2 - rack block; 3 - hydraulic jack for movement;*
- 4 - valve distributor; 5 - hydrophatron of the stability system;*
- 6 - filter at the inlet to the valve distributor*

The hydraulic diagram of the KMT-type support hydraulic drive system is shown in Fig. 4.4. Three highways are located along the longwall sections;

I - pressure head; II - drain, III - pressure head for the stability system. With the position of the remote control valve in the “Conveyor” position, the working fluid under pressure enters the line I, and in the “Support” position, into the line II. The rest of the control scheme for hydraulic props and hydraulic jacks of the support section is very simple, it is carried out with three handles and eight valves. Operating experience has shown that the presence of a separate handle for each operation (moving a section or conveyor, strutting or unloading hydraulic props) is more convenient and allows you to speed up their implementation (no need to waste time installing the distributor in the required position). Since the valve 4 is sensitive to contamination of the working fluid, a filter is installed at the inlet from the pressure line to the valve. To feed the line III of the stability

system, its own unloading machine is used, connected to the block of pneumohydro-accumulators.

Hydraulic scheme of powered support of OKP type. The hydraulic system of the support section OKP with a system of active support of the roof when moving the sections (Fig.4.5) consists of a hydraulic jack for movement 1, a hydraulic prop 2 with a post hydraulic unit 3 containing a safety and back-unloading valve, a hydraulic valve 4 of an active support unit 5, consisting of a support 6 and a pilot 7 valves and throttle 8.

The movement of the support sections of the OKP with active backwater is carried out as follows. The handle of the hydraulic jack control spool is set to position I, the hydraulic prop control spool is set to position III, then the cutter opens. The working fluid simultaneously enters the rod cavity of the hydraulic jack, under the butt of the pilot valve in the active back-up unit, as well as in the rod cavity of the hydraulic prop and under the end of the plunger of the unloading valve of the post valve body. The pressure of the working fluid closes the pilot valve and opens the unloading valve. The piston cavity of the hydraulic prop is connected through a back-up valve with a drain line and through a throttle - with a pressure head. The piston cavity of the hydraulic prop is unloaded to the back pressure, and the section begins to move.

If, at the step of moving the section, the distance between the soil and the roof decreases (steps, stabs in the roof), then this leads to the displacement of an excess amount of working fluid through the back-up valve to the drain. With an increase in the distance between the soil and the roof as the section approaches the bottom (normal roof condition), the throttle provides replenishment of the piston cavity of the hydraulic prop until the overlap contacts the roof. The pressure of the working fluid in the piston cavity of the hydraulic prop when moving the section is determined by the setting of the booster valve.

Thus, the hydraulic system of the powered support of the OKP ensures the movement of sections with constant contact of the overlap with the roof when the roof slopes both from the face to the blockage and from the blockage to the bottom, as well as overcoming some roof disturbances (falls, steps, stabs, etc.) ...

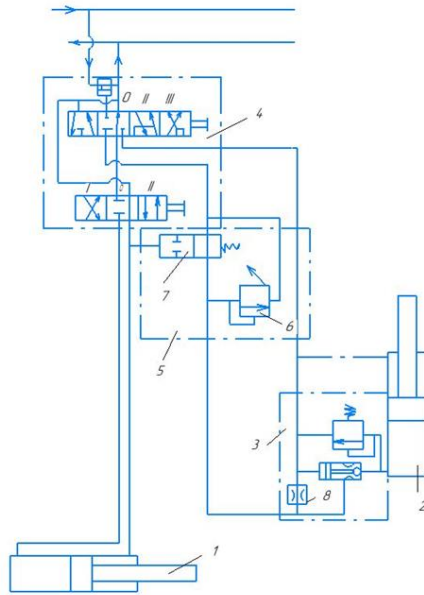

Figure 4.5. Hydraulic diagram of powered support OKP

The disadvantages of the system are a large spread in the magnitude of the back-up force when the resistance to movement changes, the leakage of a part of the working fluid of the pumping station into the drain line during all operations, which reduces the volumetric efficiency of the hydraulic drive, increases the section expansion time and reduces the value of its initial thrust.

Active backwater when moving the support sections of the OCP is provided by the use of a throttle washer as a make-up hydraulic element and an active backwater unit (Fig. 4.6.), Which consists of a body 1, a seat of a pilot valve 2, a spring of a pilot valve 3, a locking element of a pilot valve 4, which at the same time is the seat of the booster valve, the blocking element of the booster valve 5, pusher 6, booster valve spring 7, piercing 8. Cavity A is connected to the rod cavity of the hydraulic jack, B — to the piston cavity of the hydraulic prop (through the hydraulic post), and C — to the hydraulic distributor. When moving the section, the working fluid is fed into the rod cavity of the hydraulic jack and at the same time enters the cavity A of the active back-up unit. Under the action of the pressure of the working fluid, the pilot valve is closed and the discharge from the piston cavity of the hydraulic

prop is limited by a back-up valve. During other operations, the pilot valve will spring open and de-energize the back-up valve.

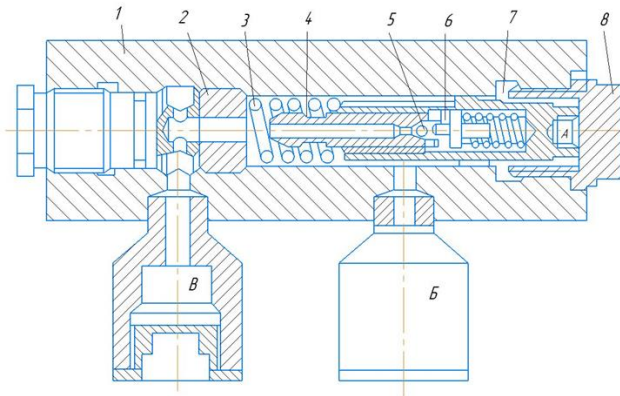

Figure 4.6. Active support block OKP

CONCLUSION

The need for effective development of coal seams lying in difficult mining and geological conditions (layers with a thickness of less than 1.2 and more than 3.5 m, unstable and difficult-to-break roofs and weak soils, disturbed, highly gas-bearing, and dangerous for mountain impacts, as well as sudden emissions of coal and gas layers, etc.) determines the main directions of development and improvement of the design of mechanized supports and their hydraulic drive systems. The creation of mechanized supports for these conditions requires the use of additional functional elements, and, consequently, an increase in the number of operations and the duration of the technological cycle. However, the creation of supports for each specific treatment face is irrational, therefore it is necessary to develop such systems that provide for the adjustment of power parameters that comprehensively link the external and internal processes of interaction of the support with the array. The solution of this problem is connected with the development of the science of hydraulic drive of mechanized supports, which includes the following main tasks:

- development of methods for calculating hydraulic elements and hydraulic systems in static and dynamic modes of operation;
- development of principles of unification of hydraulic systems of mechanized supports and main hydraulic equipment, as well as the creation of unification schemes and designs of hydraulic drive elements;
- substantiation of perspective parameters of a hydraulic drive of mechanized supports;
- development of principles of control of mechanized fasteners by creating hydraulic equipment for remote, group, and automatic control;
- improving the reliability and durability of serial and creation progressive hydraulic equipment, as well as the development of new working fluids for hydraulic systems of mechanized supports.

The nearest prospect for the development of the hydraulic system of mechanized supports is the development of unified hydraulic equipment, as well as hydraulic drive systems for a working pressure of 32 MPa (up to 50 MPa in the future), which allows you to increase the speed of lava attachment to 10 m/ min, move sections with active support, provide high load-bearing capacity, increase the initial strut and traction forces of hydraulic jacks when moving the support and conveyor, which makes it possible to increase the length of complex mechanized lavas to 200-250 m without reducing the speed of movement of the section, It is important to study hydraulic systems during group work of the jacks for moving sections and controlling additional functional elements in the presence of variable flow in the pressure and drain

lines. The solution to this problem is connected with the creation of pumps, distribution, and regulating equipment, as well as hydraulic communications (mainly High-pressure hose, High-Pressure Metal Hose, and end fittings), which must meet the working conditions at high pressure and high flow of working fluid.

In the field of improving the design of mechanized supports, the following works are being carried out abroad: ensuring a constant gap between the visor and the breast of the face in the entire range of extensibility; preventing the formation of a wedge-shaped gap from the side of the developed space between the supporting visor and the fence of the support, for example, by using "diving" or hinged visors; further increasing the bearing capacity of the support and increasing the pressure of the upper end to the roof; improving the sealing of the gap between sections in order to reduce dust load; reducing the weight of the support by improving its design and manufacturing material; reducing the cost of installation and dismantling, as well as solving the problem of fixing the face - drift.

Domestic mechanized supports of the protective-supporting and supporting type have been widely used in the coal industry. Protective and supporting mechanized fasteners have some disadvantages:

1. The relatively smaller cross-sectional area of the passage for maintenance personnel and air, which especially affects the creation of such supports for thinner layers, the large force loading of the protective part of the overlap, requiring its large dimensions in thickness even when using higher-quality heat-strengthened steels, the need to close the gaps between the sections of the support to eliminate the possibility of penetration of pieces of rock into the working space of the support, Taking into account the relatively greater hydraulic extensibility of the support sections, this is achieved by using the protective part of the support of a higher height.

As a rule, the mechanized support of the protective and supporting type has only one passage for maintenance personnel, located in the space between the downhole conveyor and the hydraulic resistance. The second passage between the hydraulic barrier and the protective part of the overlap is usually very narrow, its use in operation is inconvenient and practically excluded, the small cross-sectional area of the working space for the passage of air on gas-rich formations significantly limits the possible load on the face by the gas factor.

2. Jamming of the rock in the supports of the protective-supporting type is possible between the tail part of the supporting element of the overlap and its protective part.

3. It is not excluded that the roof rocks are clamped during the excavation of thin layers of the protective part and power connections, which are usually located almost horizontally in the developed space.

4. There is a relatively large metal consumption with equal reservoir capacity and equal average resistance of the support.

5. It is necessary to use a conveyor with active support that is more durable for the movement of sections of mechanized supports.

In recent years, research, design, and educational institutes, as well as enterprises of the coal industry, have been doing a lot of work on the research, development, and implementation of high-performance means of mechanization of the excavation of powerful shallow layers. A number of variants of systems for excavating thin layers at full capacity and with separation into layers have been tested in mine conditions. Industrial tests of mechanized complexes KM120, 2UKP-5, and KAM2S for excavation without separation into layers of layers with a capacity of 4-5 m, as well as complexes KM81V and OKPV-70 for the development of layers with a capacity of more than 5 m with the release of coal of the underlying thickness, were carried out. At the same time, the creation of new means of complex mechanization of cleaning works is not being carried out effectively enough. The improvement of the design of mechanized supports for powerful layers should be based on solving the following issues:

- to increase the reliability of the design of the contacting elements of the protective and supporting supports, retractable canopies should be used instead of retractable tops;

- to improve the processes of moving the support, therefore, the methods of roof management;

- to reduce the dynamic impact of collapsed rocks on the equipment, it is necessary to provide damping devices that will allow the roof rocks to collapse in stages;

- simplify the technological processes of coal mining as much as possible, as well as reduce the number of mechanisms and equipment used;

- to reduce the dust load, which depends on the area of the face, it is necessary to make an isolated excavation of coal in a certain part of the formation, for example, in the upper part, with frontally positioned plowing bodies;

- to simplify the installation and disassembly processes, it is necessary to reduce the parameters of the super-fasteners, i.e. some elements of the section (overlap, base) must be prefabricated, etc.

Based on the analysis of the processes of two-hole coal mining, classification of technological processes of coal mining with various schemes

of mechanized support, the main directions of development of new schemes of support are determined;

for conditions where self-destruction of coal of the upper stratum is impossible or occurs in large blocks, it is necessary to develop a technique for the forced destruction of the ceiling through the use of static executive bodies;

for the conditions of self-collapsing coal under the roof, it is necessary to create means of reliable fastening of the roof of the combine face and activating the release of collapsed coal.

The most promising direction in improving the means of complex mechanization of the excavation of powerful shallow formations is the use of modernized complexes for medium-capacity formations on them. High-quality and foreign experience in the development of powerful layers shows that as base support, it is necessary to use protective-supporting type supports with an increased cross-section, which opens up "technological" access to the redeemable underlay (interlayer) thickness, with a ceiling-like form of the face. At the same time, the excavation of the reservoir should be carried out at full capacity according to a two-hole technological scheme with mechanized repayment of the upper coal layer. This is possible when creating active mechanized supports equipped with frontal executive bodies that allow coal to be removed with low energy intensity.

The creation of active mechanized supports equipped with frontal executive bodies is of great economic importance, especially in the development of coal seams with the following mining and geological conditions for two-hole excavation: powerful shallow layers with viscous coals or strong inclusions with mechanized repayment of the underlying (interlayer) coal thickness; medium-power layers with hard-to-break roof rocks, allowing significant exposure of the roof in the bottom-hole strip and behind the support; layers of high power, especially for destruction behind the canopies of the support of the safety pack to activate the process of releasing the contaminated coal of the upper stratum; destruction and activation of the process of releasing the underlying coal stratum when excavating layers with stable roof rocks that allow significant exposure behind the support.

The development of powerful shallow layers with easily collapsible and weakly resistant roof rocks must be carried out at full capacity with the use of special mechanized supports with excavation functions that allow the destruction of the underlying coal thickness along the entire width of the section while allowing a slight exposure of the roof, the fastening of which is made immediately after the release of the destroyed coal. In order to reduce the dilution of the coal of the upper stratum and eliminate its losses in the

developed space, the working bodies should be equipped with retractable shields that serve to protect the bottom-hole space of the upper ledge from collapsed rocks.

The main direction of the development of the technique of fastening the joints of lavas is the development of mechanized supports for preparatory workings, providing simultaneous maintenance of the upper and lower faces during the layered development of powerful layers. As a permanent attachment, it is necessary to use a collapsible metal fastener, which changes its configuration depending on the convergence of the lateral rocks.

The duration and cost of installation and dismantling works in the supports of the supporting and protective type (2M81E, M130) is significantly higher than in the supports of the protective and supporting type (2OKP70, ZOKP, UKP), and depends on the removed capacity of the layers (layers), as well as on the degree of technical perfection (compactness) of the support scheme. For example, sections of mechanized fasteners 2OKP70, ZOKP enter the mounting chamber folded and they only need to be opened during installation. An important factor should be considered in the size of large-sized elements (parts and assemblies) of the support section, which should be selected taking into account their transportability along with underground workings and along the trunk. Thus, the smaller the dimensions of the elements of the support sections in contact with the roof and collapsed rocks, the faster and cheaper their installation and dismantling costs.

The efficiency of mechanized fasteners is determined primarily by the possibility of their rapid high-quality installation and dismantling.

LIST OF LITERATURE

1. Alter I. M., Nurguzhin M. R., Kuznetsov L. M. Metal structures of mechanized supports. Alma-Ata: Gylym, 1991. 128 p
2. Equipment for mechanization of cleaning operations in coal mines // Exhibition "Ugol-90". Donetsk, 1990.
3. UDC 12.44. 245-83. The supports are mechanized. Calculation of strength. Methodology.
4. PTM 24.007.01. Mechanized supports: Floors and bases.
5. Zhetesov S.S., Yurchenko V.V., Abdugaliyeva G.B. Investigation of technological parameters of a drift conveyor when excavating coal with lowering blocks // Proceedings of the International Conference "Science and education - the leading factor of the strategy "Kazakhstan-2030". - Karaganda: Publishing house of KSTU, 2008. - pp. 40-41
6. Zhetesov S.S., Beisembayev K.M., Abdugaliyeva G.B. Managing an array of mechanized supports // Proceedings of the International Scientific and Practical Conference, "Science and education - the leading factor of the strategy "Kazakhstan-2030" A.S. Saginovsky readings No. 2. (June 24-26, 2010). Part III - Karaganda: Publishing House of KSTU, 2010.- pp. 155-157
7. Zhetesov S.S., Dzhumagaziev N.B., Abdugaliyeva G.B. The main directions of improving the technology of cleaning works // Proceedings of the Moscow State Mining University. - M.: Publishing House of Moscow State University, 2009. - No. 7 - pp. 123-125
8. Zhetesov S. S., Beisembayev K. M., Abdugaliyeva G. B. research of indicators and trends of technological machines in the production of gravitational coal: monograph –Karaganda: Publishing house KSTU, 2011. – 108 p
9. Zhetesova G. S., Zhetesov S. S., Abdugaliyeva G. B. The Path of development of mining technological machines based on engineering calculations: textbook –Karaganda: KSTU publishing house, 2014 - 93 p
10. Abdugaliyeva G. B., Okimbayeva A. E. Basic equipment of the cleaning face: textbook –Karaganda: KSTU publishing house, 2021 – 80 p
11. Abdugaliyeva G. B. research of indicators and trends of technological machines in the production of gravitational coal: Study guide -Karaganda: Publishing house of KSTU, 2020. – 90 p

Abdugaliyeva G.B., Zhetesov S.S.,
Buzauova T.M., Mateshov A.K.

**WAYS OF DEVELOPMENT
AND IMPROVEMENT
OF POWERED SUPPORTS**

MONOGRAPHY

Subscribe to print 20/01/2022. Format 60×90/16.
Edition of 300 copies.
Printed by “iScience” Sp. z o. o.
Warsaw, Poland
08-444, str. Grzybowska, 87
info@sciencecentrum.pl, <https://sciencecentrum.pl>

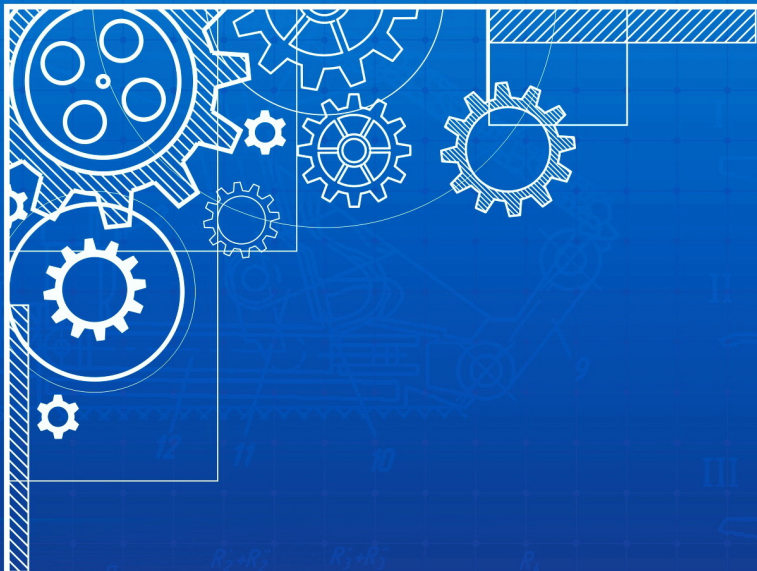

ISBN 978-83-66216-55-6



9 788366 216556