

ISBN 978-83-68188-09-7

Sinchuk O.M., Mykhailenko O.Yu.,
Horshkov V.V., Polishchuk P.I.

VARIABILITY OF FORMATS OF ENERGY-EFFICIENT STREET LIGHTING SYSTEMS FOR SETTLEMENTS

MONOGRAPH

 **iScience**

Warsaw, Poland - 2024

Sinchuk O.M., Mykhailenko O.Yu., Horshkov V.V., Polishchuk P.I.

**VARIABILITY OF FORMATS OF ENERGY-
EFFICIENT STREET LIGHTING SYSTEMS
FOR SETTLEMENTS**

MONOGRAPH

Warsaw – 2024

UDC 628.971.6:004.891:510.644:681.516.42

Authors: O.M. Sinchuk, O.Yu. Mykhailenko, V.V. Horshkov, P.I. Polishchuk

Approved at a meeting of the Academic Council of Kryvyi Rih National University (Minutes No. 1 dated August 27, 2024)

Reviewers:

Rozen Viktor Petrovych, DSc. (Engineering), Prof., (National Technical University of Ukraine “Igor Sikorsky Kyiv Polytechnic Institute”, Kyiv);

Kutin Vasyl Mykhailovych, DSc. (Engineering), Prof., (Vinnytsia National Technical University, Vinnytsia)

Sinchuk O.M., Mykhailenko O.Yu., Horshkov V.V., Polishchuk P.I.
Variability of formats of energy-efficient street lighting systems for settlements.
Monograph – Warsaw: iScience Sp. z.o.o. – 2024 – 115 p.

Street lighting in cities and settlements, fulfilling its primary purpose, plays a significant role in improving the safety of transport and pedestrian traffic. Based on open data, it has been determined that the current state of street lighting in most cities, district centers and villages of Ukraine is not satisfactory in accordance with the requirements and conditions of the present. The current negative situation is primarily due to the low energy efficiency of the system in general and the quality of light output of structurally outdated light sources in particular. The current state of street lighting systems is the result of the fact that Ukraine consumes almost twice as much electricity for lighting needs as developed countries.

Evaluating the progressive experience of other countries, it is logical to assert that in the field of street lighting, it is relevant and promising to move towards the development of automated control systems for this complex electrical complex, which is aggregative in structure and energy-intensive in terms of electricity consumption.

Regarding the implementation of the latter, from the above directions, and based on and taking into account the trends in the development of modern control systems and the fact of the process of active implementation of sources of dispersed generation, electricity, and the creativity of the latest street lighting systems in various sectors of industry and transport, hybrid (synergistic) structures of artificial lighting with the latest, in terms of technological capabilities, systems of integrated management of this process based on the intellectualization of management actions regarding the level of illumination should be added.

UDC 628.971.6:004.891:510.644:681.516.42

ISBN 978-83-68188-09-7

© Sinchuk O.M., Mykhailenko O.Yu.,
Horshkov V.V., Polishchuk P.I., 2024

© iScience Sp. z o. o.

CONTENTS

INTRODUCTION	7
CHAPTER 1. ANALYSIS OF ELECTRICAL AND TECHNOLOGICAL FUNCTIONING PARAMETERS ELECTRICAL COMPLEXES OF EXTERNAL LIGHTING OF CITIES AND POPULATED POINTS	10
1.1 Analysis of the technical and energy status of street lighting and population centers complexes in Ukraine and around the world.....	10
1.2 The status and regulations of the operation of the power supply process in outdoor lighting systems	15
1.3 Review of scientific research direction.....	20
1.4 Definition and formation of tasks of scientific research	25
Conclusions to section 1	30
CHAPTER 2. FORMATS OF STRUCTURING OF EXTERNAL LIGHTING CONTROL SYSTEMS OF CITIES AND SETTLEMENTS	32
2.1 Power supply systems are the starting points for the formation of structures of outdoor lighting control complexes	32
2.2 Scanning and variability of forecasts of electricity consumption by the city's outdoor lighting complex	39
2.3 The formation of tasks for the modernization of electrotechnical complexes of outdoor lighting with control of the process of their energy efficiency	44
2.4 Variability of the approach to the process of restructuring the electrotechnical complexes of outdoor lighting of cities and settlements	46
2.5 Communication of the control process and analysis of options for the structures of automated control systems of electrotechnical complexes of outdoor lighting.....	48
2.6 To the process of integration of means of accumulation of electrical energy into variants of synergistic structures of power supply systems with external lighting	57
Conclusions to section 2	61
CHAPTER 3. ANALYSIS AND DEVELOPMENT OF THE ELECTROTECHNICAL COMPLEX OF OUTDOOR LIGHTNING	62
3.1 Modeling of the process of controlling the electrotechnical complex of outdoor lighting.....	62
3.2 Modeling and research of the operation of the lighting installation control system.....	65
3.3 Modern aspects of building intelligent electrical networks.....	71
3.4 Algorithm of the system of intelligent control of the level of street lighting	73
3.5 General principles of building a fuzzy control system of an electrotechnical complex of outdoor lighting	75
Conclusions to section 3	78
CHAPTER 4. FUZZY CONTROL SYSTEM OF THE ELECTROTECHNICAL COMPLEX OF OUTDOOR LIGHTING	79
4.1 Justification of the choice of the control system of the electrotechnical complex of outdoor lighting	79

4.2 Development of a control system for the electrotechnical complex of outdoor lighting.....	80
4.2.1 Fuzzification.....	82
4.2.2 The rule base.....	87
4.2.3 Conditions for modeling the outdoor lighting control system	92
4.2.4 Modeling of the outdoor lighting control system	95
Conclusions to section 4	98
BIBLIOGRAPHY	103

LIST OF ABBREVIATIONS

EE – ELECTRICAL ENERGY

PSS – POWER SUPPLY SYSTEM

ACS – AUTOMATED CONTROL SYSTEM

AML – ARC MERCURY LAMPS

IL – INCANDESCENT LAMPS

FL – FLUORESCENT LAMPS

MHL – METAL HALIDE LAMPS

HPSL – HIGH PRESSURE SODIUM LAMPS

GDP – GROSS DOMESTIC PRODUCT

EL – EXTERNAL LIGHTING

PL – POWER LINES

RAEI – RULES FOR ARRANGING ELECTRICAL
INSTALLATIONS

LI – LIGHTING INSTALLATION

CCR – CENTRAL CONTROL ROOM

CP – CONTROL POINT

ACS – AUTOMATIC CONTROL SYSTEM

LCS – LIGHTING CONTROL SYSTEM

ALCS – AREAS OF LIGHTING CONTROL SYSTEMS

FOTS – FIBER OPTIC TRANSMISSION SYSTEMS

ELCS – EXTERNAL LIGHTING CONTROL SYSTEM

OLC – OUTDOOR LIGHTING CONTROL

EPPS – ELECTRONIC PULSE POWER SOURCES

CRCOL – CENTRALIZED REMOTE CONTROL OF OUTDOOR
LIGHTING

CC – CONTROL CENTER

NL – A NETWORK OF LAMPS

LCC – LAMP CONTROL CHANNEL

LCD – LAMP CONTROL DEVICE

DC – DISPATCHER'S COMPUTER

ADSS – ACCESS DEVICES TO THE SUBSTATION SERVER

EEQ – EXECUTIVE EQUIPMENT

SSE – SUBSTATION SWITCHING EQUIPMENT

LLCN – LOCAL LIGHTING CONTROL NETWORK

ALCD – AUTOMATIC LAMP CONTROL DEVICE

ILCD – INDIVIDUAL LAMP CONTROL DEVICE

SSIW – SELF-SUPPORTING INSULATED WIRE

CTES – CLOSED TYPE OF ELECTRICAL SUBSTATIONS

PCTS – PILLAR (MAST) COMPLEX TRANSFORMER
SUBSTATION
TES – TRANSFORMER ELECTRIC SUBSTATION
FLC – FUZZY LOGICAL CONCLUSION
FCSEL – FUZZY CONTROL SYSTEM WITH EXTERNAL
LIGHTING

INTRODUCTION

External lighting of streets and squares of cities and settlements, performing a number of functions specific to this electric energy complex, plays a significant role in the society as well [1, 2].

Among other positive things, outdoor lighting should play the role of additional aesthetic decoration of the facades of buildings and the city landscape as a whole in the evening and at night with the aim of creating comfortable conditions for residents of certain settlements.

As a fact of today, we note that in the world about 20% of the total amount of generated electrical energy is spent on the needs of EL systems of cities and settlements [3].

As of January 1, 2022, the total length of EL power grids in populated areas of Ukraine is more than 100,000 km, the number of light points is about 2 million units, with a trend of further growth [4].

Based on official data, from literary sources available to the author, it can be determined that the existing (general) state, such as: technical and technological EL indicators of most cities, district centers and villages of Ukraine, from the point of view of modernity, need to be improved from a number of system-forming positions [5-7].

Among such positions that exist today, and are odious for Ukraine, a special place among the indicators specific to EL systems is occupied by the problem of the need to improve the electrical energy of these complexes, since external lighting systems in Ukraine are more than twice as energy-intensive and consume almost twice as much electricity as needed lighting than in the developed countries of the world [8].

Relevance of research. In Ukraine, lighting electric networks are structurally integrated into the national energy system and represent a significant segment in the formation of electricity consumption levels, and logically, as active EE consumers, they should be among the creative actors in solving the problem of increasing energy efficiency in the country in general [9 -10].

However, with a careful analysis of the possible ways of achieving the expected effect in the energy efficiency of EL, nevertheless, the primary – basic, in the technology of their purpose, task of these complexes (for which they exist) – providing lighting quality at the maximum possible reach of this indicator [11, 12].

At the same time, the question seems logical – how can this be correlated with the power generation of these complexes? Moreover, the above-mentioned and logical tendency to expand the borders and locations of external lighting networks, with a corresponding increase in lighting points,

provokes the process of potential increase in EE consumption by these types of consumers.

Meanwhile, such ongoing and implemented organizational and technical measures necessary to reduce the levels of EE consumption, such as the use of new energy-efficient lamps and lamp designs, while giving a certain effect, are still not able to minimize the real potential of the growth rates of the levels of electricity consumption by external lighting networks in the state [13, 14].

In the list of current directions for increasing energy efficiency and reliability of PSS EL, options for power supply structures with distributed generation of electric energy occupy a special place [15-18].

Nevertheless, for greater correctness of the above interpretation, we note that, analyzing the results of the implementation of these types of PSS structures in the work practice of a number of industrial enterprises [19-20], it is obvious that such a "bare option" of potentially energy-efficient and structurally synergistic power supply systems, in its final solution format, is not able to provide an opportunity to achieve the level of their energy efficiency to the indicators of their maximum energy-efficient reach, without applying in the technology of their operation elements of control of electric power processes in this version of PSS.

For real, in the conditions of modern perception, and visible and realistically achievable horizons, expected levels of energy efficiency, it is advisable to "disengage" from the existing vision of ways to implement this process – exclusively by reducing the amount of electricity consumption, and to the extent necessary to concentrate on solving the problem of managing this process with an emphasis on the possibility not only of reducing EE consumption, although this remains a priority task in any option for solving the problem of increasing energy efficiency, but also in restraining the growth rate of this indicator.

However, when forming a "road map" of such a potentially effective solution option, one must understand that managing the levels of EE consumption over time for such complex technologically functioning and aggregatively structured systems as lighting networks is a complex multi-criteria process with a number of unpredictable and often contradictory system-forming factors both in number and in terms of their influence on the modes of operation of the analyzed electric power complex [21-27].

The above "logic of contradictions" can, to a large extent, be minimized by the above-mentioned way of controlling the process of EE consumption, according to a number of criteria and, including, the function of variability in time of the levels of light emitted by lamps. That is, the process of managing the process of EE consumption in lighting networks, in

this version, can be characterized as transit – unclear, as a function of the level of illumination.

In this version, the format of controlling lighting complexes is significantly changed, with the transition from a single-functionality option to a multi-functional one. At the same time, both the functional capabilities of these complexes – the limits of the use of technical potential, and the efficiency of their functioning as a whole – are expanding.

There are certain positive practical developments in this direction, but they are inherent, for the most part, to foreign research, where among the known and practically implemented modern technologies in the field of artificial outdoor lighting, various variants of ACS are actively implemented [28-31].

Today, the realities of the functionality of the existing versions of ACS of external lighting complexes of populated areas in Ukraine are mostly limited to operations: "turn on – turn off", in accordance with the hours of the day: evening – night.

Based on the results of the author's preventive search and taking into account the existing, significant in scope, variability and uncertainty of the limits and levels of influencing factors on the energy efficiency of the operation of external lighting networks and, according to a certain but acceptable level of bias in the assessment of the modern vision of directions for solving the stated problem, it should be emphasized that the development of EL complexes, guided by the modes of their operation, can and should rely on options that are as close as possible to the intellectual one in terms of the technology of their operation. This, accordingly, requires a careful study of the state and formalization of modern tasks and ways of solving them, which should and can be assigned to new, comprehensively effective types of electric energy systems for outdoor lighting of cities and settlements.

CHAPTER 1.
ANALYSIS OF ELECTRICAL AND TECHNOLOGICAL
FUNCTIONING PARAMETERS ELECTRICAL COMPLEXES OF
EXTERNAL LIGHTING OF CITIES AND POPULATED POINTS

**1.1 Analysis of the technical and energy status of street lighting
and population centers complexes in Ukraine and around the world**

Outdoor electric lighting must meet RAEI requirements, relevant building codes and regulations [82].

The main basic criteria for evaluating the effectiveness of external artificial lighting systems of streets and paths of city squares and other local objects are the quality of lighting, reliability, uninterrupted power and energy efficiency of the entire aggregative power complex under analysis. Without rejecting or underestimating the weight of all of the above requirements, we note that in today's conditions, the last three look particularly relevant. It is these three indicators, to a large extent, that depend on their compliance with the criteria of the technology of functioning of centralized trunk PSSs, which feed EE EL complexes of cities and settlements.

In this aspect, the indicators of the number of outages in the electricity network of Ukraine look interesting and, at the same time, very dramatic. As statistical data show, our state "dominates" here in a negative way among other countries of the world. It is logical that the facts, in fact, of at least daily outages in main power grids during the year, are the reason for the corresponding reaction to this and the lighting networks of populated areas of the state. At the same time, in order to emphasize the drama of the situation due to the fact of the loss of EE power supply of EL networks, we note that the data in fig. 1.1. relate to the years before the beginning of the large-scale aggression of the Russian Federation in Ukraine. The state, in this matter, in Ukraine from February 2022 to the present, both in energy and lighting networks, in particular, additionally emphasizes and emphasizes the need to solve the problem of continuity and energy efficiency of types of EL networks, both on the scale of the state and on the scale of individual cities and settlements (Attachment A).

According to the Ministry of Energy of Ukraine [32], the total length of outdoor lighting power grids in populated areas of Ukraine as of January 1, 2020 was more than 124.32 thousand km.

The total number of outdoor lighting installations is about 3.53 million units.

And the share of lighting installations in the external lighting networks

of the country was approximately 60% (Fig. 1.1), which, although a positive indicator, still requires constant improvement.

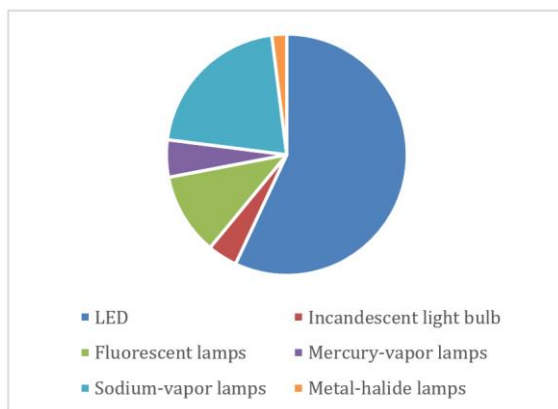

Figure 1.1 – Distribution of types of light points by types of light sources in Ukraine as of 2019

About 3.38 million units are used in the field of outdoor lighting in populated areas of our country. of energy-saving light sources (95.6% of the total number) [32].

Based on the results of the analysis of the implementation of various types of outdoor artificial lighting sources in the lighting networks of the country's settlements, it was found that the Odesa region has the highest rate of use of energy-efficient LED light sources (Fig. 1.2), which is about 90% of the total installed. But taking into account the leading indicators of the Odesa region in terms of the number of lighting installations, it still remains a negative fact that the total number of non-energy-efficient artificial lighting installations in other regions remains unacceptably high [33].

One of the main factors contributing to this negative state of affairs is that local authorities do not fully comply with the requirements of the Law of Ukraine [34], namely: in terms of the limited and insufficient amount of funding in this area, which does not contribute to the proper implementation of measures for modernization and re-equipment power grid for outdoor lighting of populated areas in modern versions.

Meanwhile, according to state statistics, the Dnipropetrovsk Region ranks among the five regions with high indicators in terms of the number of light points (Fig. 1.3) and occupies one of the first places among regions

according to the criterion of the length of power grids for outdoor lighting of populated areas (Fig. 1.4).

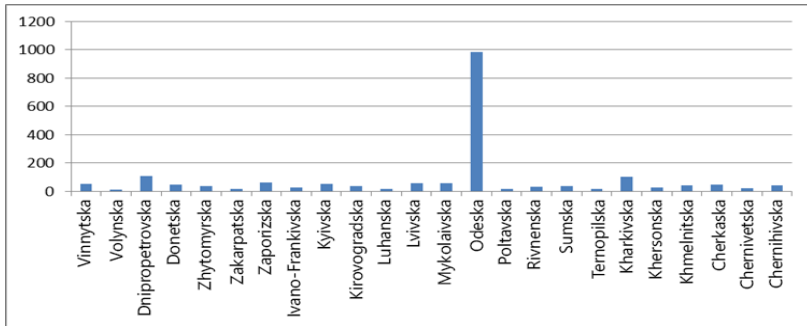

Figure 1.2 – Quantitative characteristics of LED light sources by regions of Ukraine as of 2019, thousand pcs

The results of the analysis of the share of different types of light points by type of light sources in the Dnipropetrovsk region as of 2019 (Fig. 1.5) showed that the level of introduction of energy-efficient light points in the external lighting power grids of the region is average among the indicators of other regions of Ukraine and is about 40%. In today's concepts, this is an insufficient level to the level necessary to solve the effective functioning of lighting complexes [5].

The given indicators, or rather, their levels, in addition to the above and those that will be given later, also lie in the plane of uncertainty of place in this ACS process by the EL process. However, it is ACS that can really solve a number of existing problems in EL complexes.

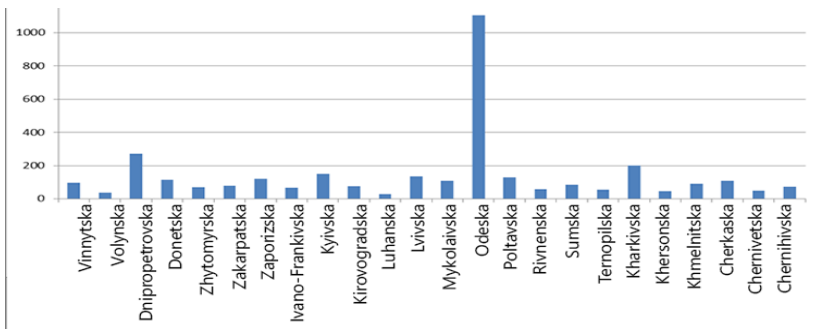

Figure 1.3 – Quantitative characteristics of light points by region as of 2019, thousand pcs

VARIABILITY OF FORMATS OF ENERGY-EFFICIENT STREET LIGHTING SYSTEMS FOR SETTLEMENTS

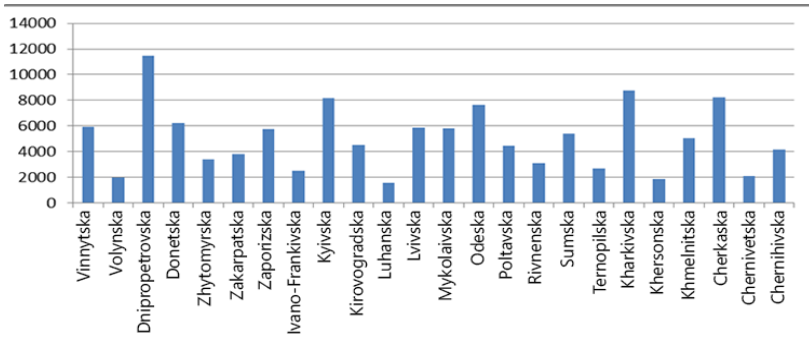

Figure 1.4 – Total length of outdoor lighting networks of settlements in the regions of Ukraine as of 2019, km

So, as of 2019, the total number of automated EL remote control systems of settlements in the country was about 17.5 thousand units. Kharkiv, Cherkasy, Kyiv, Dnipropetrovsk, and Odesa regions should be noted among the leading regions in installing automated remote control systems for outdoor lighting (Fig. 1.6) [5].

At the same time, in a number of other regions of Ukraine, the implementation of these systems remains at a rather low level.

As an example of a negative attitude towards the need to use ACS in the field of artificial lighting, the Lviv region has an almost zero level of application of these systems, and the level of EE consumption by lighting complexes is the highest among other regions of Ukraine. At the same time, Kharkiv region, which is dominant in terms of ACS implementation levels, is among the leaders of minimum consumption volumes in the field of EE consumption levels.

As of 2019, more than 820.2 million kWh were consumed by EL systems in Ukraine. electricity. At the same time, the costs for the purchase of electricity consumed for outdoor lighting amounted to almost UAH 1,433.0 million [5].

Out of 90,022 thousand electric energy metering devices, 46,279 thousand units (51.4%) are differentiated electric energy metering devices.

Lviv and Dnipropetrovsk regions should be noted among the leading regions in electricity consumption by external lighting networks (Fig. 1.7).

VARIABILITY OF FORMATS OF ENERGY-EFFICIENT STREET LIGHTING SYSTEMS FOR SETTLEMENTS

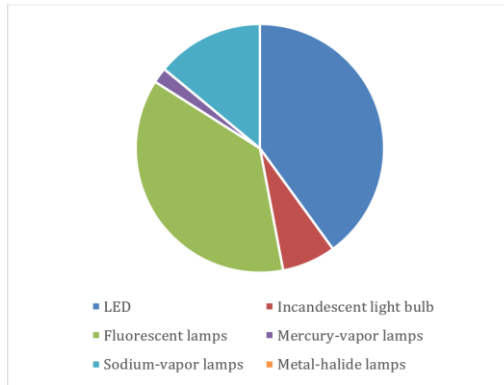

Figure 1.5 – Distribution of types of light points by types of light sources in Dnipropetrovsk region as of 2019

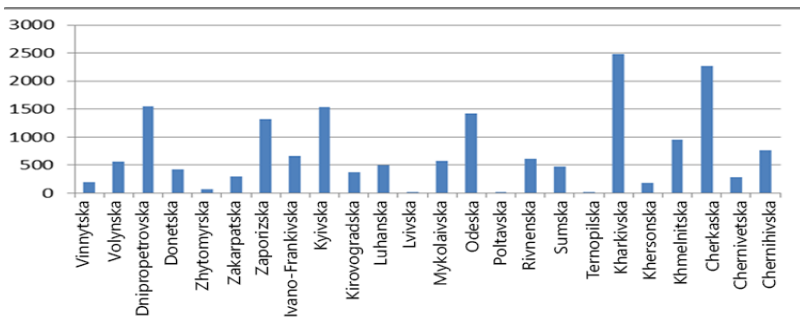

Figure 1.6 – Quantitative characteristics of automated systems remote control of outdoor lighting in the regions of Ukraine as of 2019, pcs

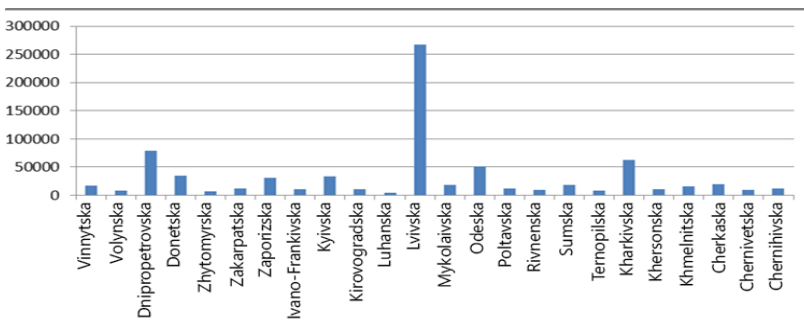

Figure 1.7 – Quantitative characteristics of consumed electricity external lighting networks in the regions of Ukraine for 2019, thousand kWh

The results of the analysis of the amount of electricity consumed by one light point showed that the following regions have the highest levels of average electricity consumption in Ukraine: Zakarpatsya, Kharkiv, Donetsk, Dnipropetrovsk, and Lviv regions (Fig. 1.8).

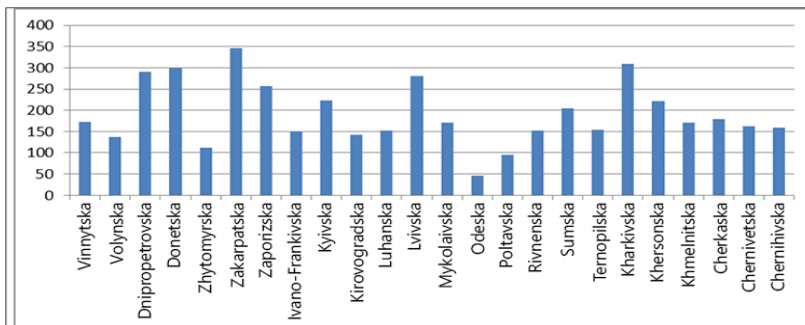

Figure 1.8 – The amount of electricity consumed by one light point by region as of 2019, kWh

In the current time period, on average, about 15% of all consumed electricity is spent on the EL of cities in Ukraine. Therefore, in the conditions of a continuous increase in energy prices and, most importantly, an acute shortage of generating energy resources in the state, as well as, despite the political situation in the country, growing requirements for the quality of lighting, which is of particular relevance for cities, as well as for all other settlements of Ukraine, the problem of reducing costs and rational use of electricity, as well as increasing the environmental cleanliness of EL installations becomes a problem.

Solving this complex of tasks, or at least approaching this process, is possible by changing the logistics of reach by reorienting this process from a variant of local solutions to a complex variant with the final format of the development of the corresponding ACS.

1.2 The status and regulations of the operation of the power supply process in outdoor lighting systems¹

When conducting an analysis of the state of operation of the EL electrical networks, we will make a preventive remark – this state, in addition

¹ Statistical data on the parameters of the technological electric energy state of EL networks, for known reasons, are mostly given for the period of 2021

to the established formats (Attachment B, C), is determined to a large extent by the specifics of landscapes, schemes of cities and other settlements, based on the general plans for their development, which include itself and segments of the development of street lighting networks (Attachments F, D).

Analyzing in a general way the ways of solving the problems of street EL, including its light output, energy efficiency, and the level of controllability of these processes, we note that the solution of the problem, as a rule, takes place over a long period of time – improving the quality of regulation – management decisions. This resulted in the application of a number of regulators. But the constant growth of the structures of EL networks, the number of lighting devices and the increase in the amount of electricity consumption caused a significant system-forming discrepancy in the schedules of the functioning of these types of EE consumers, the non-linearity of their parameters and the stochasticity of the electricity consumption regimes.

In order to prevent unforeseen, but realistically possible dramatic situations, the power supply system of EL complexes should be transformed into a single automated information-measuring and controlled complex, which will ensure optimization of its functioning modes, including the level of supply voltage and reactive energy in the network. In addition, it is necessary to meet a set of socio-economic criteria. Since the fundamental basis of the formation of criteria for evaluating the modes of operation of the electricity supply and lighting system of cities are its general tasks as a system of urban economy, which serve the global goal of this complex – to improve the living conditions of the urban population based on increasing the number and quality of services provided by EL, then formalization is necessary here levels of the respective priorities of all criteria.

The analysis in the direction of the scientific research being analyzed [10, 11, 14, 22] and the results of the author's research made it possible, in the first approximation, to identify the criteria that must be taken into account in the process of optimizing the EL system of cities. Such criteria include social, economic, ecological and technical indicators. Meanwhile, only technical and economic criteria were reflected in the well-known literary sources on technical and economic studies of energy systems. Under such conditions, the presentation of the selected criterion as a limitation of the research task is reduced to a single criterion. At the same time, it was established in [35] that the functioning of PSS and EL of cities has important social and environmental consequences and they must be taken into account when making and evaluating the effectiveness of specific technical solutions. Moreover, under modern conditions, characterized by the implementation of

market relations, in which decisions are made in the competitive environment of firms, the importance of these criteria increases even more in connection with the need to expand the volume and quality of services provided to the population. Thus, the implementation of the considered system of technical and economic indicators can look like a complex criterion that will take into account the indicators of social, technical, economic and ecological adequacy and most fully reflects the processes in the power supply and lighting systems of cities.

In such a statement, the task of optimizing the modes of operation of the city electricity supply system in general and EL, in particular, is reduced to the determination of those parameters that correspond to the maximum efficiency according to the given criteria, to which the minimization function corresponds, which is the sum of operating costs for production, transmission, distribution and transformation of parameters and type of electricity, as well as associated costs related to environmental friendliness, reliability and quality of electricity supply to consumers.

The structure of such a control system for operating modes of EL networks, which will allow monitoring and measuring the current parameters of network operation, and monitor the current state of electrical equipment and PL in a preventive version, consists of the following two levels [23]:

- the possibility of using automatic EL control using photoelectric sensors that turn on a group of lamps depending on the change in natural light, which will provide the opportunity to achieve the greatest energy efficiency;
- the possibility of remote control of lamps and the EL level of each street lamp with a guarantee of the required amount of light under different conditions. Equally important is the presence of real-time feedback, which informs of any changes that occur along the line, reduces energy losses and offers advanced tools to optimize maintenance.

Implementation of the set of above-mentioned measures to improve the efficiency of the EL system will ensure:

- uninterrupted functioning of lighting systems in the event of an external freelance intervention in the control system of this process;
- constant maintenance of objects and outdoor lighting networks in a technically sound condition;
- elimination of emergency situations on equipment and engineering infrastructure networks;
- increasing the aesthetic appeal of the city and the quality of life of the population.

In today's realities, in accordance with the existing standard voltage systems in electric lighting networks of Ukraine, light sources are produced

at a nominal voltage of 220 V and 380 V. In street lighting installations, a voltage of 380/220 V is used, light sources are switched on at a phase voltage of 220 V (Attachment G, K).

To ensure the adequacy of the selection of lighting levels, there is a unified classification of objects in urban spaces (Attachment G, H, I).

Streets and roads are classified according to their importance in the urban environment and traffic intensity. The class of the street is determined by the importance of the road, and the subclass is determined by the activity of traffic.

Pedestrian spaces belong to class P, and the types of specific pedestrian spaces are classified accordingly [36].

The subclass of pedestrian spaces is determined depending on the features of the field of vision, difficulties with visual orientation, the presence of additional users in the field of vision, the increased risk of criminal situations, as well as the need to distinguish people and create an attractive appearance of the lighting installation. This classification does not apply to sites for quiet and mass cultural recreation, as well as to underground and above-ground pedestrian crossings.

The lighting of the carriageway of streets and roads with rectilinear geometry with regular traffic is designed taking into account the norms of average brightness of improved road surfaces.

The level of illumination of the surface of the carriageway of streets and roads with non-linear geometry (squares, traffic junctions, etc.), as well as with transitional and other types of coverings, is regulated by the value of the average horizontal illumination of the surface.

The average illuminance of pavements adjacent to the roadway and squares should be close to half of the average illuminance of the roadway of these locations.

Among other things, the lighting of the tram tracks, which are located on the carriageway of the roads, should be at the level of the lighting of the corresponding street.

In outdoor lighting installations, devices with economical EL sources are used, including: high-pressure sodium lamps, metal halide lamps, low-pressure discharge lamps and LED lamps [13, 26].

In installations with difficult access for maintenance of lamps, as a rule, electrodeless discharge lamps are used, the service life of which is more than 50 thousand hours.

In the process of designing EL systems, special, currently significant, attention is paid to the optimal selection and placement of lighting devices, taking into account their light distribution (Attachment F). The criterion for

the optimization of the project solution is energy efficiency – the minimum power of the lighting system while ensuring standardized and calculated quantitative and qualitative indicators. When placing the lamps, it is necessary to take into account the possibility of convenient maintenance of the lighting fittings.

In order to ensure the visual orientation of drivers and pedestrians, lighting devices must be located in such a way that the line formed by them is clearly directed in the direction of the road. It should be noted that it is prohibited to partially turn off lamps at night in the case of their single-row arrangement and the lighting installation with one lamp on a support.

On the adjacent territory of gas stations and parking lots located next to roads with active traffic, diffused light lamps should be installed at a height of at least 3 m behind the light flux of lamps up to 6000 lm. To illuminate these, it is recommended to use floodlights located on roofs and canopies and directed towards the street or road.

The lighting of ground pedestrian crossings should provide people with a safe crossing of the carriageway and the ability to see obstacles and defects in the road surface.

In the case of design of pedestrian crossings with special light signs on each side and on the central island, they should be installed at a height of 2–3 m above the carriageway [11, 36]. The brightness of these devices should be at least 300 cd/m². The permissible frequency of flashes is 40-60 flashes per minute. In order to warn traffic participants, it is recommended to use contrasting colors of lighting in the transition zone.

It should be noted that in residential areas it is worth paying attention to the fact that EL devices should aesthetically blend with the surrounding architecture. This applies to the shape and proportions of lamps, brackets and supports, the height of the installation of lighting devices. To ensure modern design solutions for streets, it is recommended to pay attention to the architectural solutions of elements of lighting devices. It is recommended to use EL supports for installation of traffic signs, street name plates, urns, flower pots. It is necessary to ensure that green plantings do not obstruct the light flow during their growth. Meanwhile, in the case of the presence of green areas, it is allowed to illuminate the trees using lighting devices emitting a light stream directed to the upper hemisphere.

To increase the attractiveness of the living area, it is recommended to vary both the level of lighting and its color.

It should be noted that in residential neighborhoods it is recommended to use wall lights or a longitudinal suspension system for their fastening, which will ensure the safety of movement for its participants, as well as

reducing the economic component of the project.

In the case of equipping residential areas with road signs and pointers with light illumination, their brightness should be controlled in order to prevent a decrease in the vigilance of drivers and a reduction in the overall aesthetic impression.

EL requires control that is independent of the lighting control of the buildings themselves. Meanwhile, EL control can be situationally located directly in the building.

The purpose of improving the standard was to ensure at a high level the unity and accuracy of measurements of energy parameters, radiation and to expand its functionality to new types of FTAs, including for FOTS. The main task is to improve metrological characteristics, expand the dynamic range for reproducing, storing and transmitting a unit of continuous radiation power in a light guide and expanding its functional capabilities, namely: equipping the standard with equipment for reproducing, storing and transmitting a unit of radiation propagation time in a light guide. The specified standard is the highest link of the state verification scheme for these types of measurements. The advanced standard is intended for reproduction and storage of units of average power in the radiation pulse, power of continuous radiation in the light guide and propagation time of radiation in the light guide, as well as for the transfer of the size of the units to working standards and directly to the working means of measuring equipment used in the country aimed at ensuring the unity and unambiguous accuracy of measurements in the fields of modern electronic and computer telecommunications, defense industry, scientific research, optical location, telemetry, etc.

The reproduction of a unit of power of continuous light fluxes of radiation in a light guide, the source of which is a stabilized laser, is based on the measurement of radiation power using a reference primary measuring transducer [38].

The above-mentioned measures to improve the general efficiency and energy efficiency of artificial lighting networks in cities and settlements represent a basic component for the format of a new stage of scientific research.

1.3 Review of scientific research direction

As noted in the previous text of this research manuscript, the scientific search for solutions to the problem under analysis has never stopped, beginning its journey from the first moments of the implementation of

electrical EL standards in the cities and towns of Ukraine. However, the emphases in search tactics have changed over time and are changing, which is provoked by changing situations and the state of compliance of existing EL systems with the ever-increasing requirements for them.

This is also reflected in the tactics of conducting research, especially in recent decades, where the emphasis is on the implementation of automated control systems for lighting networks with the involvement of artificial intelligence elements in the EL algorithm [16, 22, 26, 39-41]. Good results have been achieved, most of which relate to foreign research.

Thus, one of the leading companies in the implementation of modern technologies in EL is the Sibelga company, which manages street lighting in a number of cities on the planet and which, together with the Schreder company, tested a new innovative system of smart street lighting in Bois de la Cambre, a large city park in the south of Brussels (Belgium) [42]. This area of the city is an ideal place for testing the option of "smart" lighting, because an important traffic artery passes through this park, which means that the traffic can be very intense: cars, cyclists, pedestrians. Furthermore, as this green space is rich in biodiversity, it was appropriate to minimize any light pollution. Adaptation of the light flux of 72 CITEA NG LED lamps installed on the road and in the park took place according to data collected in real time. This data was not collected by sensors installed on the lamps, but through online databases on the Internet.

Three types of data were collected: weather conditions, traffic intensity and location of pedestrian crossings. The data provided from the databases allowed the Schreder EXEDRA system to calculate the optimal light levels for each light point and, if necessary, to adapt the light flux to real-time conditions every 15 minutes. The luminous flux was varied in 3 levels (100%, 75%, 50%) to meet the necessary lighting standards of the city. Thus, over a full calendar year, this type of system can provide a 10% increase in energy savings. In addition, the reduction of light flux made it possible to minimize any light pollution, without affecting the safety and comfort of people moving on the road.

The above options of adaptive systems can be especially interesting for areas where the intensity of traffic changes significantly and stochastically. This fact provokes the further direction of new directions of scientific research in the development of the theoretical foundations of the construction of adaptive control systems of EL systems.

In [43], the main criteria that the authors recommend to be taken into account when designing road lighting with optimization of the use of electricity using genetic algorithms are given. In papers [44-49], as well as in

a number of other papers [50-54], project proposals of the author's visions regarding the implementation of intelligent EL control systems are outlined. Works [55, 56] define their vision of EL systems in variants of "smart" cities.

An informative and, at the same time, instructive factor, which crystallized as a result of the author's familiarization with the "search portfolio" of research by foreign scientists in this direction, into a significant scientific block that opens up the possibility of using EE storage batteries in EL complexes.

In [57], the expediency of using different energy storage systems for EL systems of roads using solar power plants is analyzed. Lead-acid and lithium-ion batteries, supercapacitors and hybrid energy storage systems are considered. The results show that lead-acid, lithium-ion batteries and supercapacitors provide satisfactory active power quality for efficient charging in all solar radiation ranges. The use of lead-acid batteries gives the lowest installation cost, while lithium-ion batteries have the best durability. The cost of supercapacitors is too high to be used as an energy storage system for solar street lighting systems. However, they can be involved in combined systems with batteries to reduce current fluctuations and active power for battery charging.

In [58], the performance of an autonomous photovoltaic system for ZO using storage batteries and a hydrogen system for electricity storage is investigated. Complete mathematical models of both systems have been built. They are modeled for the real climatic conditions of the city of New Borg El Arab (Egypt). The results showed that the annual lighting load can be covered with 160 m² of photovoltaic panels in the case of hydrogen storage and 40 m² for the battery system. In addition, the overall system efficiency is higher for a battery system.

The study [59] focused on the optimization of a stand-alone photovoltaic system with lithium-ion batteries for LED EL in Magetan province (Indonesia). The optimization process included the selection of battery capacity, charge controller, power of photovoltaic panels while complying with power supply requirements and project limitations. Technical and economic analysis of the system was carried out based on PVGIS solar resource assessment. The simulation showed the efficiency of street lighting with the use of lithium-ion batteries.

The work [60] is devoted to the evaluation of the performance of lithium-iron-phosphate (LiFePO₄) batteries as storage devices for an autonomous photovoltaic system EL. Experiments show that when using LiFePO₄ batteries, there is a difference between the input and output energy of the battery, which mainly affects its deficit – about 10% in each

charge/discharge cycle. The obtained performance value of the LiFePO₄ battery can be a reference for designing an autonomous photovoltaic street lighting system. The result indicates that the system needs a higher peak output power of the PV system for the application of LiFePO₄ batteries.

Summing up the analysis of foreign research, which is insignificant in scope, but sufficient for understanding and perceiving the scope of scientific achievements of foreign seekers of solutions to EL problems, we note that most of them were performed "addressed" for specific conditions and at the initiative of customers – municipalities, communities, etc.

Significantly, in terms of the format of the research approach, the works of domestic scientists differ from foreign ones. The developments of our scientists are of a more generalized nature with a touch of uniformity of solutions.

In the development of these ideas, a cohort of domestic scientists, including: L.A. Nazarenko, K.I. Ioffe, V.O. Saltykov, O.M. Sinchuk, Yu.P. Mysyuk, R.V. Pylypchuk, E.O. Reitzen, S.Yu. Potalitsyn, V.A. Andriychuk, P.P. Alekseev, V.O. Artemchuk, T.R. Bilan, O.L. Dekusha, A.O. Zaporozhets, V.P. Rosen, A.V. Sapryka, P.P. Govorov, M.S. Tarasenko, A.K. Kindrinova, I.M. Trunova, L.Yu. Volotka, T.L. Nasedkina and a number of others [61-79].

Scientific research [68] is devoted to improving the efficiency of lighting installations based on the use of LEDs and DNAT lamps in the lighting system. A database has been developed that allows assessing the efficiency of outdoor lighting during operation. The use of LED-based luminaires in existing outdoor lighting systems is analyzed. The principle of ensuring a normalized thermal mode of operation for LEDs during current control is substantiated. An optical system for LED luminaires is proposed, which allows creating a narrowly directed luminous flux for use in decorative and artistic illumination of streets, sculptural compositions, buildings and parks of cities, which reduces the loss of luminous flux and does not create excessive light pollution. A scheme has been developed to allow the luminous flux to be adjusted from 50 to 100% for DNAT lamps.

In [69], the author's approach to the implementation of EE saving measures in city-wide PSS is proposed.

In works [70], the development of the regulatory framework of EL in Ukraine and an analytical review of the work of international energy organizations regarding the state and scenario of the development of the analyzed segment, the global energy sphere, are considered. The issue of lighting as one of the key factors in improving road safety is covered in detail. Three levels of obtaining information in the process of driving a car are

defined: positional, situational and navigational. A specific example of the calculation of visibility – a possible indicator of EL regulation in future regulatory documents – is given.

Scientific works [71] analyzed the current state of electricity consumption in Ukraine by lighting systems, paid attention to operational processes, and provided recommendations for increasing the energy efficiency of EL lighting systems.

In [72], the focus of research was on increasing the energy efficiency of EL by improving the quality of EE in PSS.

In [73], the ASS EL variant is proposed. Research [74] is devoted to the specifics of evaluating the light output of lighting devices based on Svitlo Lux LED sources. The results of scientific research, which are presented in works [75-77], provide the necessary input data for the energy audit of EL systems and corresponding solutions for improving the energy efficiency of the latter.

Logistics in evaluating the effectiveness of ACS ZO in the specifics of the realities of their application are outlined in [78].

A number of works are devoted to the analysis of the development of data collection systems, information technologies, in particular, the Internet of Things (IoT) [82-83], EL control tools, which are commonly called smart. Their use will significantly reduce the level of electricity consumption by lighting network equipment.

For example, a large-scale review of smart EL control methods is given in [85]. Among them, those that use the methodological apparatus of fuzzy logic [86-92], management with predictive models or machine learning stand out due to their high efficiency.

At the same time, fuzzy logic inference systems have become the most popular due to their simplicity. However, these systems have their own characteristics.

In [86], the fuzzy control system of a separate lighting installation consists of two fuzzy subsystems. One of them adjusts the brightness of the LED lamp, depending on the lighting and light noise. Another is the duration of inclusion depending on the speed of the car. In [87], the author provides a practical implementation of the system.

A fuzzy street light control system is also proposed in [88]. Its inputs are the level of sunlight and the presence of the object in the area of the lighting installation, and the output is the brightness level of the LED lamp.

In the article [89], the author developed an intelligent fuzzy streetlight control system based on information from vehicle speed and light sensors, which allows for advance regulation of the number of lights in front of the

vehicle, as well as the level of illumination of LED lamps. The system allows you to dynamically control traditional street lights according to specific conditions on the road at night.

Note the work [90]. It proposes a fuzzy system of dynamic adjustment of artificial EL brightness, taking into account various factors, such as: intensity of natural light, intensity of light noise, and speed of motor vehicles. The proposed fuzzy control algorithm significantly reduces the energy consumption of the lighting device.

Another street lamp control system based on fuzzy control theory is proposed in [91]. The brightness of each LED lamp can be adjusted according to the level of natural light. The author established that the method allows achieving energy savings. However, we note that the control system does not take into account the presence of vehicles or pedestrians.

Article [92] is devoted to the development of the concept of energy saving in EL systems by controlling the brightness of LED lighting devices. The proposed system is equipped with sensors for determining the intensity of natural light, the movement of the vehicle on the road, as well as rain detection. The output value for the system is the brightness of the lighting.

The analysis of the literature indicates that EL electrotechnical complex control systems, which use fuzzy logic methods, are focused only on the level of illumination (as the main value) and the intensity of traffic, but do not take into account the electricity tariff when generating the value of the control action by voltage or current (depending on the type of LED driver). Also, none of the reviewed systems provide recommendations for choosing an autonomous power source for the lighting installation, although some of the recommended options have solar panels with batteries.

Scanning the results of known perfect studies in the author's evaluation of what has been achieved looks in such a way that no matter how meticulously we analyze these searches, we cannot do without complimenting them here. It is these studies, both positive and negative, of the final results in the variants of searches that gave and give the opportunity to continue the process of scientific research in the very relevant issue being analyzed.

1.4 Definition and formation of tasks of scientific research

The creative format of building EL systems and complexes, in their modern vision, has existed in Ukraine for a considerable period of time [3-18]. These improvements, and more precisely, their positive aspects, are known and appreciated by the residents of the country's cities and towns.

However, as a fact of today, it can be affirmatively stated that the limit of the post-Soviet research format in solving EL problems has been exceeded, as well as the potential of fruitless solutions. In the current period of time, in the cities and settlements of Ukraine, similar to or close to world models, certain stages of the complex of modern directions – solutions within the framework of the implementation of relevant city and regional programs, which organically include components of EL systems.

The basic goals of such programs are:

- restoration, reconstruction and construction of outdoor electric lighting networks;
- bringing EL electrical networks in accordance with the norms and standards of the current legislation;
- equipping outdoor lighting facilities with equipment using energy- and resource-saving technologies;
- improvement of the state of improvement of settlements;
- improvement of the criminogenic and emergency situation at night, the comfort of living of the population;
- reduction of injuries among the population in conditions of unsatisfactory condition of roads, insufficient visibility due to weather conditions;
- reduction of electrical energy consumption by EL objects.

Expected results of the implementation of the "Programs":

- to ensure the implementation of the state policy regarding development, primarily in the area of improvement of settlements;
- to ensure an increase in the level of security of life support systems in settlements;
- to improve the quality of housing and communal services for the population;
- reduce the number of emergency situations at EL facilities;
- create conditions for the safe movement of motor vehicles and pedestrians;
- to create an effective system of accounting and regulation of electric energy consumption, its rational use for the lighting of populated areas;
- reduce energy consumption, increase the energy efficiency of the EL street and road network.

However, as noted in the previously presented material, the problem, albeit in a somewhat veiled form, exists in the EL cities of Ukraine, and in recent years, for known reasons, it has been brought to the level of drama of the situation and the need for an accelerated solution with new options.

First of all, it concerns the continuity and energy efficiency of EL. The

implementation of a solution to such a problem requires a new, additionally scientifically based approach to the search for not always traditional solutions. But it is precisely without such an approach that it is difficult, or rather impossible, to achieve the desired effect, which can be achieved with the help of ACS.

Automation of EL control can and should ensure adaptation of the illumination level of lighting devices to the set of variable conditions in which they must function. The list of such conditions includes: hours of the day, weather features, and pedestrian or vehicle traffic. In addition, a very important factor of such an action will be the fact that controlling the level of illumination will provide an opportunity to actually reduce the amount of electricity consumption, which is an aspect of the sustainable development of cities and towns.

The social component of the consequences of the operation of EL complexes should also not be dismissed. Automated control of lighting devices allows the use of light points only when there is a need for it, i.e. even during those hours of the day when the external lighting was completely turned off before, will provide an opportunity to increase the comfort level of city residents and increase the attractiveness of the city itself for the population. Moreover, such inclusion will not have a significant impact on the level of electricity consumption due to the low intensity of vehicular and pedestrian traffic in the dark, as well as the possibility of creating sufficient lighting at a power below nominal. This statement needs theoretical and experimental confirmation.

At the same time, it should be understood that the trajectory of the process of solving the problem of increasing the efficiency of EL functioning, in time, can reach long terms, and the intensive period at the same time – significant material investments.

Nevertheless, in order to achieve the set goal, the introduction of the latest technologies in the format of the development of control systems for the operation of EL complexes is a necessary, inevitable and unalternative solution at the level of its reach.

The starting point in such a decision format should be the scientific justification and practical recommendations for the implementation of research results for their approval in the realities of projects for the development and operation of EL complexes in the conditions of cities and populated areas of Ukraine.

Based on the results of the analysis of the state assessment and the realistic possibilities of modern reproduction of the levels of achievement of increasing the efficiency of the functioning of EL networks, the author's

generalized logistic scheme for the practical implementation of such a project was developed (Fig. 1.9).

It is clear that each local direction from the complex, when implemented, is able to give a full positive effect in increasing the energy efficiency of EL. It is also clear that the maximum effect can be achieved only with the final solution of the entire complex of tasks. Overcoming such a path is a difficult process both in terms of time and required material resources, but there is no alternative to this option in the final achievable expected level of energy efficiency EL, although the trajectory of developing the format of such a complex solution can be and, most likely, will be heterogeneous with a certain variety of solutions.

Taking into account the fact that this work, from the author's point of view, is designed to supplement existing and previously obtained results in the direction of increasing the livelihood of settlements, through the development and application of comprehensively effective electrotechnical EL complexes, through the use of modern management methods of controlling the process of the operation of lighting devices to achieve the set goal, it is necessary to determine the following.

The purpose of this study is to increase the level of energy efficiency and uninterrupted functioning of the electric lighting networks of cities and settlements both in regular and non-regular operating conditions, by applying modern methods of intelligent management of the modes of operation of lighting devices and the levels of light emitted by them.

To achieve the goal and the logistics of its implementation in the process of scientific research, the following scientific tasks were set and solved in the research scheme:

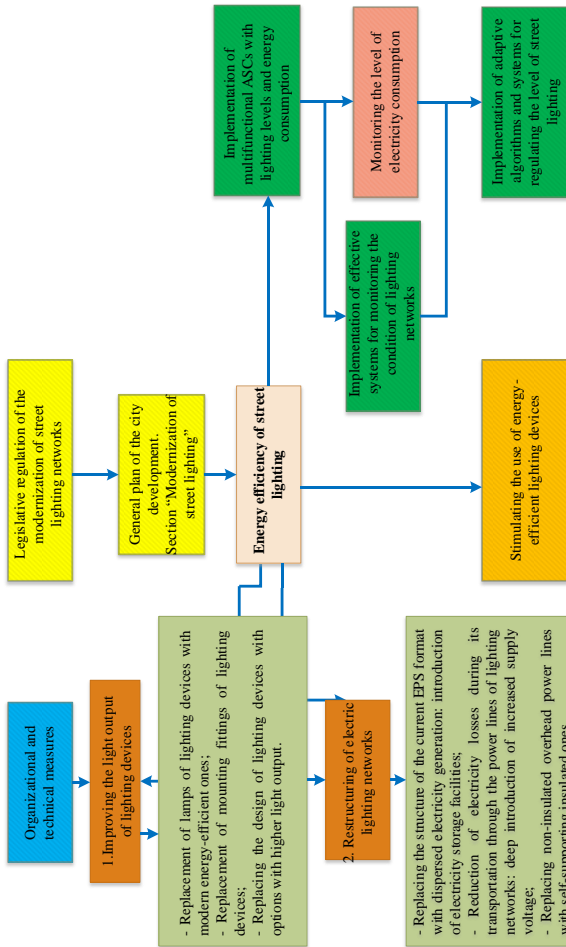

Figure 1.9 – The main directions for improving the efficiency of outdoor lighting networks in cities and settlements

- on the basis of the analysis of the existing state, formalize the system-forming factors that affect the energy efficiency, quality and continuity of artificial street lighting in cities and settlements; determine and evaluate the options for increasing the levels of the above indicators with the maximum approximation of them to modern requirements by choosing the format of a creative solution;

- to theoretically justify and develop a methodology for choosing a variant of the structure of an energy-efficient, functional technology, street lighting power supply complex for the conditions of cities and settlements with its multifunctional system for controlling the modes of lighting devices as a function of a number of influential system-forming factors;

- to develop an adequate simulation model of the electric power complex of street lighting with the possibility of researching its modes and determining the optimal parameters and ranges of the effective functioning of lighting complexes and systems, with the variability of evaluation and ranking, according to the levels of stability of the factors influencing this process;

- to establish the relationship between the current state of the levels of natural street lighting and the required level of additional artificial lighting when justifying and identifying input and output parameters for the implementation of the law of adaptive control of work modes, both the lighting system as a whole and local lighting devices, in particular, in accordance with real indicators of illumination, to develop a version of the ACS structure for managing the process of lighting the streets of cities and settlements of the corresponding electric power complex with the involvement of elements of artificial intelligence.

With a significant level of correctness, the results of both specified and unspecified, due to the limited scope of the research notes, we emphasize the significant practical orientation of the authors' searches in this matter – as a component of the EL energy efficiency improvement complex, and as a result – implementation in specific projects. In Ukraine, so far, there is a lack of practical implementation of these components from the entire PSS EL modernization complex.

Conclusions to section 1

1. Outdoor lighting complexes of cities and settlements of Ukraine represent energy-consuming types of electricity consumers, which, in accordance with and in accordance with their generalized functional purpose – creating comfortable conditions for the population, differ among themselves in the individuality of architecture, development, levels of electricity consumption, types of lighting devices and minor differences in

the technology of hourly functioning. For a number of both objective and not entirely objective reasons, the analyzed electrotechnical complexes, in the modern vision of today, do not meet the growing criteria both in technology and in the energy aspect of their functioning to a sufficiently necessary extent and require solving the relevant problems.

2. A trivial, but direct in the field of system-forming realities of the expected positive, attainability effect in the direction of increasing the efficiency of the components of the functioning of outdoor lighting complexes, according to the functioning of the proposed format of the "road map" of achieving the goal, is the integration into the technology of their work of the process of adaptive control, which, based and reflecting on the functional indicators – the level of illumination and the level of electricity consumption and, taking into account the rating of the conformity of the influencing factors, will fill the package of input-output parameters into the structure of the algorithm of management actions.

CHAPTER 2.
**FORMATS OF STRUCTURING OF EXTERNAL LIGHTING
CONTROL SYSTEMS OF CITIES AND SETTLEMENTS**

**2.1 Power supply systems are the starting points for the formation
of structures of outdoor lighting control complexes**

The structuring of project formats of EL schemes is carried out situationally, in accordance with the landscape, architecture of a particular city or settlement, as well as in accordance with and on the basis of existing norms and standards [4], including in accordance with [93].

As noted in the previous section of this study, according to the established practice of building EL structures in Ukraine, their power supply systems, as a rule, are implemented with a TNS grounding system through power points from transformer substations of general PSS of a particular city or settlement. EL networks, having different execution structures, nevertheless consist of a number of sequentially connected sections of the cascade – cascade variants (Fig. 2.1) [37].

The construction of EL networks, today, as cascade options, provides a practical possibility and what is implemented – regulation of the consumed electrical power of these complexes by turning them on in the evening (part of the lighting is turned off) and night (all lighting is turned on) modes of operation, for which the cascades have phases night and evening modes of operation.

Currently, street lighting is managed using fairly simple algorithms. As a rule, after sunset, with the onset of dusk, lighting devices are turned on at 50% power, with the onset of night, EL light points begin to work at full power. After that, the outdoor lighting works without changing the mode of operation until 11 p.m., after which it is turned off until dawn. However, this is a generalized mode that may change depending on the city or town, the intensity of traffic and pedestrian traffic, etc. [94].

For example, in the city of Kyiv, 50% of light points are turned off between 11:00 p.m. and 6:00 a.m. [95]. This partial shutdown is explained by the high pace of life in this city. In the Poltava community, the streets along the trolleybus routes are illuminated from 11:00 p.m. to 12:00 a.m., after which the outdoor lighting is turned off until morning [96]. In the city of Kryvyi Rih, from 11:00 p.m. to 5:00 a.m., the lighting network is almost completely turned off, and at 5 a.m. it is turned on again until dawn [97]. This is due to the fact that the city is industrial and the end of the night shift or the start of the day shift in factories starts very early, that is, workers need to get

to the workplace or go home. Of course, all the work schedules described above correspond to peacetime, during martial law they are usually not observed for obvious reasons.

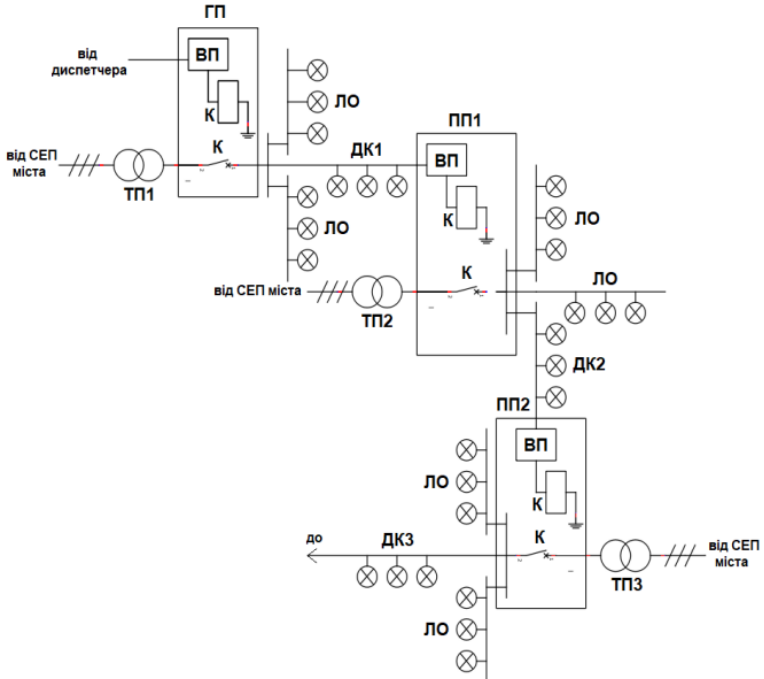

Figure 2.1 – A typical structure of a branched cascade circuit outdoor street lighting where: TES (1, 2, 3) – substation transformers of the power supply system; PL – power supply lines of lighting devices; SK (1, 2, 3) – sections of the outdoor lighting complex cascade; C – power contactors; EP – executive points of cascades of the control complex external lighting

Such an approach to outdoor lighting control can be considered manual, which limits and even makes impossible the use of technological potential, which a priori can be achieved in the field of controlling the efficiency of the EL complex, because special means, such as: remote control, etc., are used in this case only during switching on/off lighting devices, and energy consumption regulation as such does not occur at all.

A typical variant of the existing technology of operation of EL networks in the hours of the day is given in the table. 2.1 and Fig. 2.2 [37].

Table 2.1 – Variability of the functioning of the outdoor lighting system during periods of the day

Type of commands	Modes of operation		Mode of operation of a three-phase network feeding
	Night	Evening	
Turn off the lighting	Off	Off	De-energized
Turn on 100%	On	On	Full phase
Turn on 50%	On	Off	Partially phased

Control of EL networks is carried out, as a rule, centrally and remotely by dispatchers from control points with the help of switchgear-contactors. Telecontrol systems are also used with discreteness when transmitting commands and continuity – in the mode of monitoring the technical condition of EL networks [37].

Networks of EL complexes of cities and settlements in Ukraine are formats of related, or close to this definition, variants of structures [94-96]. However, a number of cities have their own system, which forms a variable specificity of the structuring of EL networks. Often, it is this specificity that determines difficult additional problems and, first of all, regarding the energy efficiency indicators of EL as electric energy complexes, as well as the development of their control systems. As stated in subsection 1.1 of this study, one of the most difficult options in the queue for the formation of the structure and control system of EL systems is the city of Kryvyi Rih (Dnipropetrovsk region) [97].

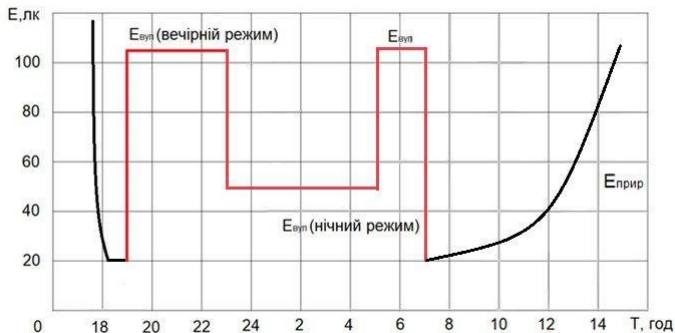

Figure 2.2 – A variant of one of the canonical schemes of functioning outdoor lighting during city hours

The analyzed city has a unique structure both in terms of trajectory the

development of EL systems, as well as the length of the corresponding PL.

In connection with this interesting point, according to the complexity and scope of the expected research, as a scientific search, in the direction being analyzed, there is an analysis of the state of development of the EL structure, PSS parameters and levels of EE consumption by the EL complexes of this city, with its complexity and peculiarities of the structures external lighting of streets and squares [33, 98-100].

Analyzing the state of performance indicators of EL networks on the example of the city being analyzed, it is reasonable and realistic to state that over the last ten years, the system-forming operating parameters of their work have practically not changed, but, most importantly, they have not improved.

At the same time, we should note that the structuring of the lighting scheme in the city of Kryvyi Rih is much more complicated than in most settlements of Ukraine. This is related both to the length of the city's streets, some of which reach several tens of kilometers, and to its landscape. The latter is difficult to format into a clear system or scheme, because the landscape of the city is interspersed with a lot of man-made man-made disturbances [97-100].

In the current period, about 27% of the city's land area is used for industrial areas of quarries, mines, waste rock dumps, sludge storages and reservoirs of mineralized waters, which are pumped into the underground horizons of mining enterprises. Moreover, with the expansion of the above-mentioned man-made phenomena, which takes place in the realities of the functioning of the city's industry, the location of lighting networks also changes.

In addition to the violation of the natural state of the city's land areas, which is about 35 thousand hectares, with their subsequent permanent destruction (note that for the extraction of 1 million tons of iron ore, an average of 3.2 hectares of land must be removed), there is air pollution, which is reflected in pollution of everything that is in the open air, including on lamps.

In the forecast period until 2031, the volume of electricity consumption in the city was planned to grow by 2.3% per year, and the overall growth of electricity due to the introduction of renewable sources – by 3% annually, and its share should reach from 18% to 30% in 2030 year. However, the current situation will most likely affect these plans negatively.

In the current period of time, according to the construction structure, the city's electrical networks are a classic example of industrial centers of Ukraine. The region's main electrical networks include overhead power lines with a voltage of 330 kV and 5 electrical substations with a higher voltage

level of 330 kV ("Rudna" substation, "Pershotravneva" substation, "Kryvorizka" substation, "Girnycha" substation, "Pivdenna" substation) (Fig. 2.3, 2.4)

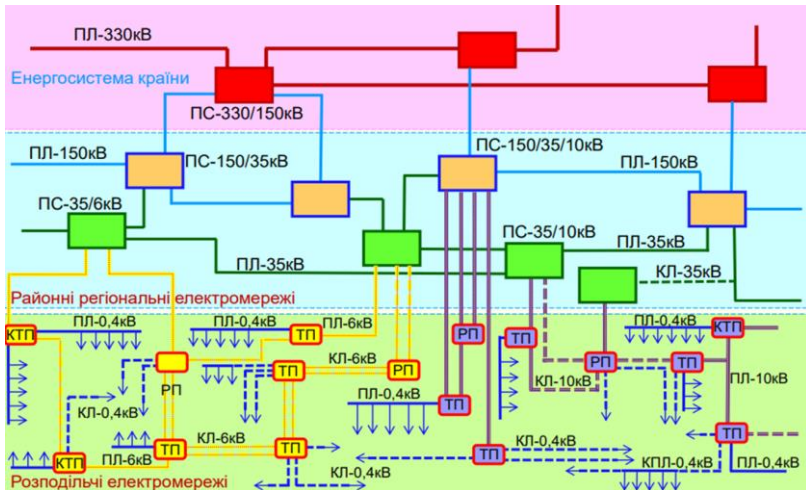

Figure 2.3 – The structure of the distribution of electricity received the city of Kryvyi Rih (Dnipropetrovsk region) from the energy system of Ukraine

The district electric networks of the city with a voltage of 35-150 kV are formed by overhead power lines of 35 kV and 150 kV, cable power lines of 35 kV and power substations with a higher voltage level of 35 kV and 150 kV, which are on the balance sheet of industrial enterprises and the Distribution System Operator JSC "DTEK Dniprovskiy power grid", which operates on the territory of the Dnipropetrovsk region. The total number of these electric substations is about 120, of which only 20 are serviced by DTEK (150 kV – 9, 35 kV – 11).

In connection with the fact that the city of Kryvyi Rih developed simultaneously with the development of iron ore deposits and the construction of mining and mining and processing enterprises, metallurgical enterprises, machine-building enterprises for the needs of the mining and metallurgical industries, most of the power centers of the district electrical networks were located precisely at these enterprises.

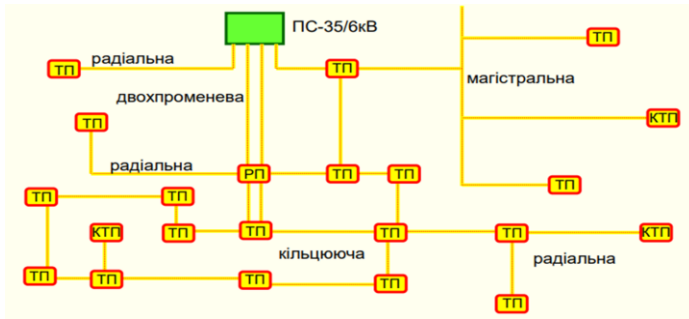

Figure 2.4 – Schemes of electrical networks of the city of Kryvyi Rih (Dnipropetrovsk region), Ukraine

The city's electrical networks transport electricity directly to household and legal consumers and consist of overhead and cable lines with a voltage of 10 kV, 6 kV and 0.4 kV, as well as distribution points of 10 kV, 6 kV and transformer points of 10/0.4 kV, 6 /0.4 kV. Most of these networks are under the service of JSC DTEK Dniprovski Elektromerezhi, which, under the terms of the Contractual Relations, provides uninterrupted power supply to consumers of electricity with standardized parameters of the quality of electricity.

Distribution electric networks of 6-10 kV of the city (Fig. 2.4) are mainly made by the combined method. At the same time, two-beam, ring, radial and main connection schemes are used between feeder substations, distribution points and transformer points. This method ensures the maximum reliability of electricity supply to end consumers of electricity (Table 2.2).

When choosing a power supply scheme, reliability requirements, construction conditions and economic feasibility are taken into account. The more reliable the power supply scheme, the more expensive the costs for design and construction and installation work.

Table 2.2 – Characteristics of urban electrical networks

No	Indicator	Quantity, items	Length, m
1.	Overhead power lines 6-10 kV	280	219,6
2.	Overhead power lines 0,4 kV	1254	1135,8
3.	Power transmission cable lines 6-10 kV	1427	871,7
4.	Power transmission cable lines 0,4 kV	3294	772,4
7.	Distribution points (DP) 6-10 кВ	55	25 010
8.	Transformer points (CTES) 6-10/0,4 kV	971	469 034
9.	Transformer points (KTES) 6-10/0,4 kV	145	37 003

A total of 1,971 6-10/0.4 kV power transformers with a total installed capacity of almost 660 MVA are in operation in the city distribution electric networks.

To compare the ratio, we can cite the data that the nominal generating capacity of only one turbogenerator of a thermal power plant is 300 MW, and that of a nuclear power plant is 1000 MW.

The electricity supply of private sector urban housing estates is mainly provided by overhead power lines of 0.4 kV with separate inputs to each residence.

The electricity supply of two-, three-, four-, and five-story multi-apartment residential buildings built before the 1970s is provided mainly by overhead electric lines of 0.4 kV with inputs to input and distribution points of 0.23-0.4 kV buildings.

Electricity supply to other residential buildings, public buildings and communal facilities is provided by 0.23-0.4 kV cable lines.

In the compact conditions of urban development, preference is given to the use of power supply cable lines laid in the ground or in other underground structures (communication manifolds, tunnels, etc.). It is under these principles that appropriate changes were recently made to the rules for designing electrical networks and to building regulations.

If local conditions allow the use of 6-10 kV or 0.4 kV overhead power lines for power supply, then they are provided with a self-supporting insulated wire – SIW, which allows to increase the reliability of power supply (reduce the number of emergency shutdowns or other unplanned interruptions of power supply to consumers) and to increase the safety level of operational maintenance of PL-0.4 kV in the presence of a large number of people and transport. The 6-10/0.4 kV transformer substations exist as a closed type, the construction part of which is made of bricks, concrete blocks or slabs. KTES is a complex transformer substation made in a metal case and has relatively smaller installation dimensions and construction costs than CTES. In open electrical installations of the PCTS type – column (mast) complete transformer substation, communication devices on the high voltage side and power transformers are installed in the open. In such TES, all equipment is fixed on reinforced concrete risers, including the low-voltage cabinet. Such electrical installations are mainly dead-end type.

The main current measures, which are in the implementation plans before implementation, regarding the modernization of the PSS of the EL complexes of the city of Kryvyi Rih (Dnipropetrovsk region) are given in [97]. Unfortunately, the fullness of these measures, although necessary and still limited local solutions, are not able to provide an opportunity to achieve

the desired and at the same time achievable level of complex efficiency in general and energy efficiency in particular.

2.2 Scanning and variability of forecasts of electricity consumption by the city's outdoor lighting complex

As noted in Section 1 of this scientific research and according to the goal, the cumulative nature of this research is formed on the process of managing the existing electric energy processes, they represent a system-forming complex of influence on the above-mentioned process and are characteristic of EL systems in general and individual subjects – cities, in particular.

In order to confirm this postulate, we will conduct an analysis of the electrical and energy state of EL in the same city of Kryvyi Rih, based on statistical materials obtained over the last 10 years. At the same time, we will assume, not without reason, that the prediction, based on the statistics of the predictive values of such indicators and, most importantly, the development of the relevant solutions based on the obtained data, with their subsequent implementation in the practice of EL operation, will allow, by determining the variability of the development of the relevant schemes, to significantly affect the level energy efficiency EL.

Table 2.3 provides the values of indicators of the levels of electricity consumption by street lighting in the city of Kryvyi Rih (Dnipropetrovsk region) in the period from 2014 to 2023.

Table 2.3 – Indicators of the levels of electricity consumption by street lighting

I. Installed electrical capacity of the city's lighting network (kW)									
2014	2015	2016	2017	2018	2019	2020	2021	2022	2023
38566,1	41222,3	44568,5	45755,5	45755,5	45755,5	45755,5	45755,5	45755,5	45755,5
II. Levels of electricity consumption by street lighting (kWh)									
2014	2015	2016	2017	2018	2019	2020	2021	2022	2023
14980 000	17833 900	18593 842	18692 374	20705 598	17331 494	18030 988	17475 465	8686 635	7634 690
III. Length of lighting networks (km)									
2014	2015	2016	2017	2018	2019	2020	2021	2022	2023
1582,7	1622,4	1733,3	1835,56	1837,59	1837,59	1837,59	1837,59	1837,59	1837,59
IV. Number of electrical substations in the network (pcs.). (External lighting control cabinets)									
2014	2015	2016	2017	2018	2019	2020	2021	2022	2023
541	552	552	512	562	562	562	566	566	566

We visualize the provided information in accordance with the table. 2.3 (Fig. 2.5)

VARIABILITY OF FORMATS OF ENERGY-EFFICIENT STREET LIGHTING
SYSTEMS FOR SETTLEMENTS

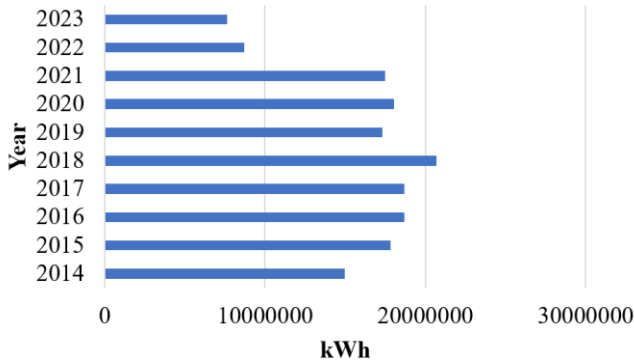

Figure 2.5 – Levels of electricity consumption by outdoor lighting of the city of Kryvyi Rih (Dnipropetrovsk region) in the period 2014-2023.

Further, in accordance with and in accordance with the "canons" [101], we will approximate the graphically presented information in order to highlight the trend – fig. 2.6.

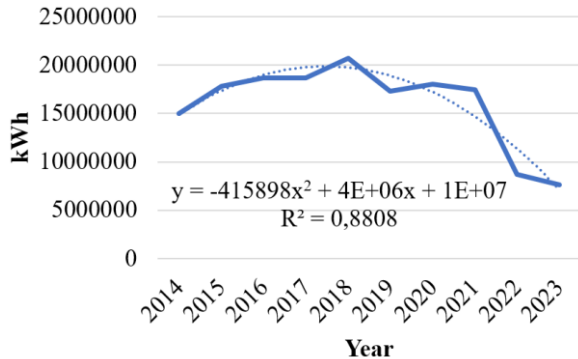

Figure 2.6 – Graphic representation of the trend of the values of the indicators of the levels of electricity consumption for outdoor lighting in the city of Kryvyi Rih (Dnipropetrovsk region) in the period 2014-2023

In the option being analyzed, there is obviously the use of an approximating polynomial of the second degree, which reflects the trend of the process development and is equal to:

$$Y = -415898x^2 + 4 \cdot 10^6x + 10^7 \quad (2.1)$$

VARIABILITY OF FORMATS OF ENERGY-EFFICIENT STREET LIGHTING
SYSTEMS FOR SETTLEMENTS

Obviously, the polynomial meets the requirements of adequacy, because the coefficient of determination is 88.1%.

Therefore, the resulting analytical dependence (2.1) can be applied to further determine the forecast.

We can also obtain the values of the forecast of the levels of electricity consumption by street lighting by applying the appropriate software and information according to the table. 2.4.

At the same time, we will receive calculated and visualized data – fig. 2.7.

Table 2.4 – Forecast of street lighting electricity consumption levels

Timeline, (years)	Value, kWh	Forecast, kWh	Low probability binding, kWh	High probability binding, kWh
2014	14980000			
2015	17813900			
2016	18692374			
2017	18692374			
2018	20705598			
2019	17331494			
2020	18030988			
2021	17475465			
2022	8686635			
2023	7634690	7634690	7634690,00	7634690,00
2024		6777469,1	675434,70	12879503,46
2025		5920248,2	-904764,78	12745261,09
2026		5063027,2	-2417890,23	12543944,70

It is easy to note that there is a tendency to decrease the values of the indicators. This is explained by the realities of today. It should also be noted that the forecast is a probabilistic indicator, the values of which may change depending on the relevant information.

It is appropriate, in today's realities, to compare the values of the forecast of the levels of electricity consumption by street lighting, using information until 2022, considering it as force majeure circumstances (Fig. 2.8).

VARIABILITY OF FORMATS OF ENERGY-EFFICIENT STREET LIGHTING SYSTEMS FOR SETTLEMENTS

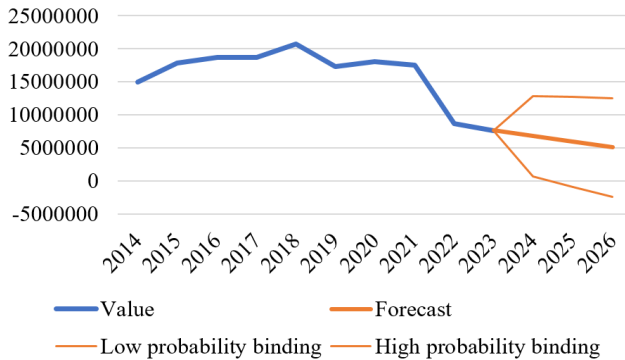

Figure 2.7 – The value of the indicators of the forecast of the levels of electricity consumption by outdoor lighting in the city of Kryvyi Rih (Dnipropetrovsk region)

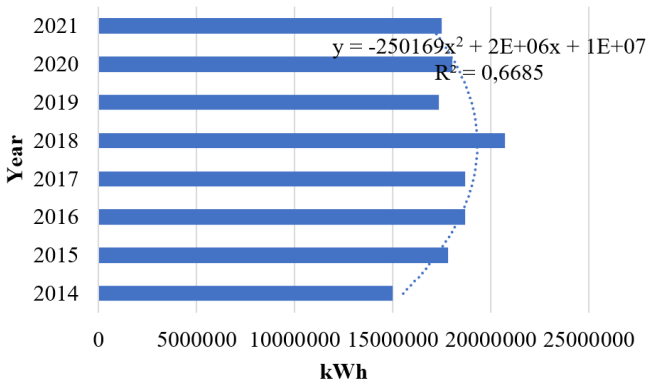

Figure 2.8 – Graphic representation of the trend of the values of the level indicators electricity consumption by outdoor lighting in the city of Kryvyi Rih (Dnipropetrovsk region) in the period 2014-2021

By grouping the data, we visually note the decrease in electricity consumption by outdoor lighting.

Accordingly, we will get an analytical dependence on the trend. We have a polynomial of the second degree (Fig. 2.2):

$$Y = -250169x^2 + 2 \cdot 10^6x + 10^7 \quad (2.2)$$

The coefficient of determination is 66.8%, respectively.

That is, there is the expediency of building a forecast with the

**VARIABILITY OF FORMATS OF ENERGY-EFFICIENT STREET LIGHTING
SYSTEMS FOR SETTLEMENTS**

appropriate bindings from the table. 2.5 (Fig. 2.9).

Table 2.5 – Forecast of street lighting electricity consumption levels

Timeline, (years)	Value, kWh	Forecast, kWh	Low probability binding, kWh	High probability binding, kWh
2014	14980000			
2015	17813900			
2016	18692374			
2017	18692374			
2018	20705598			
2019	17331494			
2020	18030988			
2021	17475465	17475465	17475465,00	17475465,00
2022		17879421	14582592,48	21176249,16
2023		18077403	13954388,74	22200417,48
2024		18275385	13464381,97	23086388,85
2025		18473368	13059624,20	23887111,20
2026		18671350	12714180,96	24628519,03

We note the growth of forecast indicators, therefore it is logical to determine the comparison of forecast values with the initial information – 2014-2021 and 2014-2023 (Table 2.6).

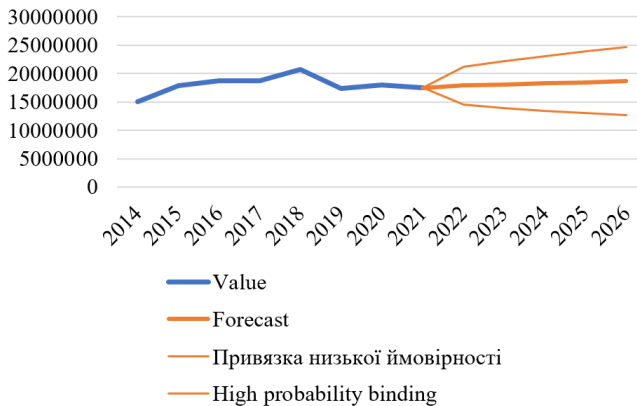

Figure 2.9 – The value of the indicators of the forecast of the levels of electricity consumption by outdoor lighting in the city of Kryvyi Rih (Dnipropetrovsk region)

Table 2.6 – Comparison of forecast values of electricity consumption levels for outdoor lighting in the city of Kryvyi Rih (Dnipropetrovsk region) in the periods 2014-2021 and 2014-2023.

VARIABILITY OF FORMATS OF ENERGY-EFFICIENT STREET LIGHTING
SYSTEMS FOR SETTLEMENTS

Period	Forecast	2014-2021	2014-2023	Δ (difference)
2024		18275385	6777469,1	11497916,33
2025		18473368	5920248,2	12553119,54
2026		18671350	5063027,2	13608322,76

It is easy to note that 2022 and 2023 contribute to the formation of the trend, as indicated by the difference in the values of the corresponding forecast indicators. Meanwhile, returning to the previous conclusions, we note that the indicators of 2022 and 2023, as well as the future year 2024, are not typical, since the mode of operation of the analyzed complexes was far from established by years until these periods. The "blame" for this reduction is the introduction of curfews, during which the street lighting systems did not function, and the disabling of significant areas of these complexes due to their damage as a result of the corresponding actions of the aggressor country. It should also be noted that forecasts are probabilistic indicators, the values of which may change depending on relevant information.

However, even with such limited information (Fig. 2.9), there is obviously a fact that with PL length, electric power and other parameters of lighting networks in the analyzed city unchanged, the levels of EE consumption by EL complexes tend to fluctuate, which can be characterized as stochasticity.

Thus, the difference between the levels of EE consumption by the EL complexes of the city in 2019, compared to 2018, amounted to (-) 17.3%, and in 2020 to 2019 – about (+) 4%, and in 2021 to 2020 – about (-) 3%.

Such fluctuations, even at insignificant levels, lead to inconsistency in the plan-fact allocation of funds from local budgets for the payment of EE consumed for street lighting.

2.3 The formation of tasks for the modernization of electrotechnical complexes of outdoor lighting with control of the process of their energy efficiency

According to RAEI, "in cities and settlements, at industrial enterprises, it is necessary to provide for centralized management of outdoor lighting."

According to [93], control of the EL of cities should be carried out from one central control point, but in large cities with terrain obstacles it is possible to provide for district control points. In turn, EL control systems must ensure that it is turned off within no more than 3 minutes. [93].

That is, it is obvious that the format of the tasks for the search and

development of new, modernly aimed at achieving the efficiency of EL systems of populated areas should logically be integrated into the basic standards of the relevant criteria-requirements for these electrical engineering complexes, which basically look like [3, 4]:

- sufficient, according to normative documents, and uniform lighting of the surfaces of street coverings and areas of populated areas;
- absence of light shading when objects move along the working surface of streets and squares;
- protection against blinding pedestrians and drivers of vehicles by the light source;
- selection of effective directions of distribution of artificial lighting from lighting sources.

The implementation of these requirements in the practice of development and construction in the EL structure contributes to increasing the level of efficiency of the use of artificial light sources when they are used as part of electrical engineering complexes for outdoor lighting of populated areas and increases the level of energy efficiency of lighting complexes as a whole.

The main factors that have a significant impact on the design logistics structure and the process of modernization of electrotechnical complexes of EL cities and settlements include [4, 8, 13, 22, 36]:

- average statistical intensity of pedestrian and vehicle traffic;
- road category;
- the number of traffic lanes;
- the presence of underground or overpasses;
- features of the construction of the pedestrian path;
- availability of a bicycle path;
- availability of officially authorized and designated parking spaces;
- the building ratio of the studied quarter;
- availability of social, administrative or commercial and entertainment facilities;
- the type and condition of the road surface and footpath;
- the distance from the support of the lamps to the edge of the carriageway, etc.

Functionally, the dependence of the EL control system is the dependence of the power of the lighting installation on natural illumination $P=f(E)$ (evening, night). To obtain this dependence, it is necessary to determine the dependence of the illumination created on the road surface by the lighting installation on the power $E_{ocb}=f(P)$. Illuminance on the road surface can be defined as the sum of the level of illumination created directly

by the lighting installation and natural illumination $E_{\text{д.п.}}=E_{\text{ооб}}+E$. To find each of the terms of this sum, it is necessary to know the power of the light source and the angle of incidence of its rays on the calculation plane. Meanwhile, for an artificial light source, these parameters can be calculated, and for natural light, they will depend on many random factors of a stochastic nature [4].

Further, having defined the level of illumination on the road surface as equal, normalizing and accepting natural illumination as an independent variable, the dependence $P=f(E)$ can be found.

In this regard, it is difficult to express the formalization of the generalized task of finding the dependence $P=f(E)$ analytically, taking into account the nonlinearity and dependence on a number of random factors, which, in turn, make a difference depending on the specific conditions of operation of EL complexes, which complicates the development of the format of the desired controllability of this process in order to achieve the expected limits of efficiency in general and energy efficiency, in particular

In order to determine the specifics in the starting positions for the development of logistics management of EL processes, the necessary moment is to address and evaluate the real parameters of the functioning of these complexes. To do this, it is advisable to conduct a test version of the analysis on the example of the current EL structure.

2.4 Variability of the approach to the process of restructuring the electrotechnical complexes of outdoor lighting of cities and settlements

Considering the traditional approaches to the implementation of power supply systems in general, and for outdoor lighting networks of cities and settlements, in particular, until recently, as a rule, their modernization was carried out and is carried out exclusively by replacing outdated converting, switching and protective equipment with more modern ones. Unfortunately, as a rule, this was done not systematically enough, but rather, a priori, by methods of impregnation. At the same time, the very principle of organizing the work of electric power systems was not subject to change. This is the fact that the external lighting of cities and settlements as the functioning of PSS electrical networks with a significant specificity of their functioning in relation to common beam, are examples of low efficiency and those that do not demonstrate their compliance with modern requirements.

In contrast to the existing PSS EL options, it should be noted the rapid pace of development and practical application of the modern approach to the implementation of power supply systems, which was called "smart grids" [39,

40, 66]. This option is considered by the state agencies of the leading countries of the world, which regulate issues in the field of energy, as the main stage of the development of energy systems for industrial and civil purposes for the period up to 2050.

At the same time, the analysis of publications, regulatory documentation and examples of the implementation of "smart" electric power systems made it possible to determine that, at present, there is no single concept for their construction. Note that the definition of the term "smart networks" is also not clearly formulated. Each vision of this concept interprets it differently [102].

In connection with this fact, as a variant of the author's vision of this interpretation in accordance with the purpose of the study, and based on known interpretations of the format of the essence of the definition of the concept of "smart" electrical networks, the outdoor lighting system, in the modern version, should perform the following functions:

- automatic switching on or off of light devices by the ELCS command, according to the algorithm of the corresponding management actions;
- disconnection of relevant groups of lighting devices according to the schedule or in accordance with the command from ELCS;
- monitoring and transmission of relevant information about the state of control cabinet equipment via a GSM modem;
- automatic transmission of ELCS information regarding temperature rise or the appearance of signs of smoke in control cabinets when smoke or temperature sensors are triggered;
- transmission of information about attempts to break into control cabinets and informing about the location of the cabinet and the time of the break-in attempts;
- the possibility of expanding the functionality of cabinets for other tasks when using free inputs of the controller;
- remote setting of relevant cabinet parameters from ELCS to the cabinet via GSM channel.

In the above format of the proposed variant of the EL structure, there are obviously a number of advantages compared to a conventional lighting system, namely:

- additional electricity savings due to the installation of sensors for the presence of people and sensors of external lighting;
- adaptation of the level of illumination and color temperature in accordance with the design features of users, such as the creation of an ecologically comfortable illuminated environment for people;

- availability of automation, which ensures comfortable use of the system;
- functional diagnostic parameters to simplify maintenance;
- maintenance of a constant amount of luminous flux of lamps during the service life of the lighting device.

Intelligent functionality of lighting systems can be implemented in the context of decentralized or centralized control systems. When implemented in centralized control systems, wired or wireless communication networks are used.

The main functions of sensors in lighting systems are as follows:

- detecting the presence of people;
- measurement of the level of external illumination.

2.5 Communication of the control process and analysis of options for the structures of automated control systems of electrotechnical complexes of outdoor lighting

In the development of any options and their technological orientation in ACS structures, the type of communication between the control center and the receiver, i.e. the control signal transmission channel, is an important point of the final level of efficiency of the functioning of these systems.

At the same time, no matter how trivial the phrase: "To perform any action requires at least two devices: a transmitter and a signal receiver", behind it is a very difficult process of its practical implementation. An important and system-forming point in this complexity is that one of the above-mentioned devices, or both, can work both as a receiver and as a transmitter of control signals. For significant knowledge of the level of complexity in this problem, there is such a measure as RF technologies [102]. And despite the fact that the beginning of the application of these technologies can be considered the moment of the invention of the radio, the use of such options for the transmission of control commands during the automation of EL installations became possible only recently.

The cohort of well-known scientific specialists in the direction under analysis agrees on the need for adaptability to the changes that are taking place during the development of ACS in many industries, but in the industry of EL controls, this application for the transportation of control signals has not yet been implemented. However, even test implementations of ACS with these types of communication in conditions of EL systems have an impressive effect, first of all, from an economic point of view, as well as from a functional point of view in the general vision of the process of managing this

object [103-106].

At the same time, it is clear that the functions of ACS may change, but the information transmitted will constantly contain such values as illumination, the presence and intensity of traffic on the road and pedestrian side of the street, air humidity, temperature and other parameters, both natural and of artificial origin. At the same time, the usual OLC system can be scaled and expanded with additional sensors, and it follows that the system has additional opportunities for expanding controllability limits [107].

The existing EL wireless control concept is optimal for many areas where ACS are used. But it is not yet an "incentive" for the widespread use and dissemination of this technology among specialists who set requirements for appropriate ACS EL engineering solutions. To stimulate the introduction of wireless devices, it is possible to use economic advantages and the possibility of "fine" adjustment of the controllability level, which is a necessary criterion for EL systems of cities and settlements not only in accordance with technical standards, but also taking into account city-wide needs.

And the fact that, since the project of such a system has a potentially high level of functionality in the EL control process, the use of a central server, which is a component of this control structure, will lead to a 40% reduction in electricity consumption and allow to reduce operating costs by 30% [107]. At the same time, it should be taken into account that the occurrence of malfunctions with this system is predicted to be determined and recognized instantly, which will lead to a reduction in the time of operation of the lamps by 75% [107].

Evaluating the results of the implementation of wireless EL control systems opens up the possibility of saving electricity for city lighting up to 40% of the current one [104].

For the implementation of the algorithm of ACS EL structuring and functioning, a necessary moment should be compliance with the regulated indicators of illumination levels, according to which, if the normalized brightness is more than 0.8 cd/m², or the average normalized illuminance is more than 15 lux at night, a decrease in the level of street lighting is allowed [69-73]:

- by 20% when the intensity of traffic is reduced to $\frac{1}{2}$ of the maximum value (k_{\max});
- by 30% when the intensity of traffic is reduced to $\frac{1}{3}$ of the maximum value (k_{\max});
- by 40% when the intensity of traffic is reduced to $\frac{1}{4}$ of the maximum value (k_{\max});

- by 50% when the intensity of traffic is reduced to $\frac{1}{3}$ of the maximum value (k_{\max}).

That is, for the category of roads of classes A and B and subclass C1, it is possible to adjust the luminous flux from street lamps with lamps, in which it is possible to regulate the luminous flux as a function of the magnitude of the current passing through them.

Since the intensity of traffic is not a constant value, but depends both on the category (class) of the road, and on the season and time of day, on the state of the road surface and its lighting, and weather conditions, it is therefore possible to adjust the EL of the road depending on the above of the listed factors, taking into account periodic external luminosity in different time intervals.

Control logistics – regulation of ZO is carried out by adjusting the luminous flux of lamps, and the sources of luminous flux are the lamps with which they are equipped. However, not all existing types of lamps are suitable for adjusting the smooth change of light flux (Attachment G).

Thus, gas-discharge lamps with a 15% reduction in current have a negative effect on the stability of gas-discharge combustion, which causes flickering and a decrease in the life of the lamp as a result of accelerating the failure of the electrodes [8, 11, 13, 36, 65, 69].

In LED lamps, the light source is LEDs, which have a high light output and a long service life, and also have the ability to deeply adjust the light flux from 10% to 100%, and a fairly easy way to implement it, by changing the strength of the current that passes through the LEDs [70].

In LED lamps, in order to regulate the luminous flux, electronic pulsed power sources are used, with the help of which it is possible to adjust not only the magnitude of the luminous flux of the lamps by changing the strength of the current that will pass through the LEDs, but depending on the complexity of the EPPS may have some intellectual properties, as a result of the presence of a microprocessor or microcontroller, which ensures the performance of self-diagnosis of the system, monitoring of the state of the LEDs and the state of the electrical power network, determine the working time intervals of turning on the lighting system, according to the previously set schedule (graph of the intensity of the light flow and working intervals of the time of day during a certain period).

If there is a communication channel between the network of lamps equipped with EPPS and the dispatching service, it is possible to transmit information about the status of the EPPS operation and the performance of the lamps in order to identify deviations in the operation of the EPPS and lamps that need to be replaced.

So, the type of equipment of the EL control system has a number of additional advantages from the point of view of economy, namely: 1) reduction of operating costs and detection of a lamp that has failed; 2) reduction of monetary costs for lamp replacement or its repair; 3) timely detection of a deviation in EPPS operation and its replacement; 4) timely identification of the location and cause of malfunction (deviation in operation) of lamps.

Centralized EL remote control (Fig. 2.10) of city roads is a complex of the following components interconnected into one system: 1) dispatch center; 2) server; 3) substation; 4) a network of lamps equipped with EPPS and photodiodes; 5) lamp control channel; 6) lamp control device.

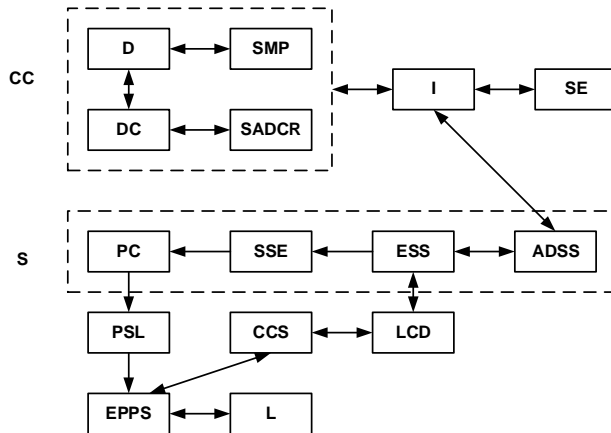

Figure 2.10 – Structural diagram of the functioning of the centralized dispatching control of a network of outdoor lamps lighting with centralized remote control: CC – control center; S – substation; SE – server; I – Internet; PSL – power supply of lamps; CCS – luminaire control channel; SMP – specialist in maintenance and programming; D – dispatcher; DC – dispatcher's computer; SADCR – server access device from the control room; ADSS – server access device from the substation; EES – executive equipment of the substation; SSE – substation switching equipment; PC – power contacts; LCD – lamp control device; EPPS – electronic pulse power supply of lamps; L – lamps

The Internet network is a means of communication, which is a modern communication type of EL control between the dispatcher's computer and the server through the server access devices and the Internet network, and then through the server and the Internet network and access devices to the substation server and to the executive and switching substation equipment

and RMSU [9, 10, 25, 33, 35].

Having received information from the server, which was transmitted from the computer, the executive equipment of the substation provokes the power contacts of the switching equipment to take appropriate action, ensuring the supply or disconnection of the power supply voltage of the lamps to the lighting unit or line and the lamps that are connected to this substation [81].

In order to regulate the luminous flux of lamps, the substation must be equipped with a control device for the lamps that are connected to this substation. The executive equipment of the substation "exchanges" information received from the server with the control device of the lamp. The dispatcher's computer software must provide control of both individual luminaires and groups of luminaires.

In accordance with the set schedule for changing the level of external lighting, the DC software sends a command to change the level of light flux on specific lamps. The EES transmits the input information (command) to the LCD, which, together with the lamp control channel connected to it, forms a local lighting control network. Analyzing the received command, the LCD determines which lamps from the entire control network should change the amount of light flux, and sends a control signal for these lamps through the control channel. The lamp control channel can be different in terms of its implementation:

- as a separate cable with control conductors;
- wireless KKS using a radio channel;

KKS with the use of already existing power lines connected to the lamps.

The circuit diagram of the EL provides for remote control of the power supply of lamps by

DC↔SE↔EES↔SSE↔PC↔PSL↔EPPS↔NL, as well as remote control of the luminous flux of lamps by: DC↔SE↔EES↔LCD↔LCC↔EPPS↔NL. CC communicates with S and SE through the Internet, having two-way communication. And through the PSL and LCC, the lamps are powered and the luminous flux level of the lamps is controlled through the EPPS, which provides feedback through the LCC↔LCD↔EES with SE and CC through I, which ensures the transmission to the CC of all information about the status of the EPPS and the performance of the lamps, which reduces the level of operating costs and repairs in the local lighting control network. At the same time, the executive equipment of the substation analyzes the information received from the SE and has the ability to exchange information with the LCD, which through the lamp control channel transmits the

appropriate command to the EPPS, which accordingly controls the level of light flux, individual lamps, and transmits the received information from the network lamps through LCC↔LCD↔EES↔SE↔DC, through, I controller.

If the LCD is on the ALCD, which contains a non-volatile real-time clock and the ability to always determine the date and time of day, with the ability to change the level of the light flow of each day during the calendar year, in accordance with the previously submitted lamp control schedule, with the determination of a specific lamp with the level of change of the light period days Then the ALCD determines the control commands for the level of outdoor lighting, which are transmitted through the control channel of the lamps through the EPPS to a specific lamp at a certain time of the day, corresponding to the year.

This ALCD device functions independently of the executive equipment of the substation and controls the lamps according to the KKS, which can be implemented in various ways. In the presence of ALCD, there is no need to improve the control center and the server, which are a complex with a fairly simple organization of the local EL control network.

If ALCD provides additional functions for controlling the switching equipment of the electrical network of lamps with a calendar control schedule through the switching equipment of the substation, then the operation of the local network of outdoor lighting control without the presence of a dispatch center and server is possible, and the need for CC, SE, S communication through I disappears. And, therefore, under these conditions, lighting management becomes virtually centralized, and the structural scheme provides for a significant reduction of material and monetary costs for the arrangement of LLCN, as well as for its maintenance and operation.

At the same time, the decentralized outdoor lighting control system has a number of disadvantages, namely:

- when making changes to the lamp lighting control schedule, in order to make changes to the ALCD program, there is a need to have an ALCD service specialist and make changes to the program at the substation;
- there is no feedback on the state of LLCN functioning;
- it is not possible to control the lighting at the moment without a specialist visiting the substation;
- structural complexity and increased cost of ALCD.

The decentralized EL control system assumes (Fig. 2.11) the absence of a dispatch center, server, server access devices, as well as the Internet as a means of communication, executive equipment of the substation and replacement of LCD with ALCD, as well as the presence of service personnel who will service the substation equipment ALCD, SSE and PC, as a result of

the lack of feedback from the ALCD to the OP, that is, S is serviced directly by service and programming specialists.

The lamp control channel is an expensive piece of equipment, and if it fails, the ability to control the level of light flux from the lamps disappears.

And in case of failure of ALCD, or in the event of malfunctions, it is possible to repeatedly disconnect the control of the power supply of the lamps and the control of the light flow from the lamps.

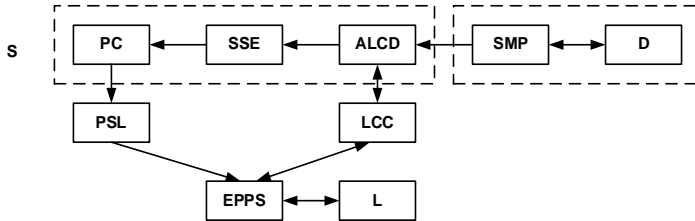

Figure 2.11 – Schematic diagram of decentralized control of outdoor lighting on city highways and in public places: D – dispatcher, SMP – specialist in maintenance and programming, S – substation, ALCD – automatic lamp control device, SSE – substation switching equipment, PC – power contacts, PSL – power supply of lamps, LCC – lamp control channel, EPPS – electronic pulse power source, L – lamps

Feedback between the ALCD of the substation and the SE unit can be established by equipping the ALCD and the SE unit with radio communication, which, in turn, will significantly affect the cost of the equipment control system.

Other options for organizing the external lighting control system of roads with heavy traffic may be realistically possible [33, 43-46].

The principle scheme of mixed control of lamps provides for centralized control of the power supply of lamps and autonomous control of the level of luminous flux from lamps, in accordance with real weather conditions, the level of atmospheric pollution, the general level of illumination, the surface of the road and its physical condition, the intensity of traffic, the time of day.

The schematic diagram of the mixed control of external lighting of roads with heavy traffic involves the operation of light flow control from lamps that are additionally equipped with lamp control devices by integrating the LCD into the EPPS or separately mounted in the lamp, and therefore in the future we will refer to it as an individual lamp control device. The ILCD functions in autonomous and automatic modes, in accordance with the

previously submitted light flow control schedule and depending on the specific external environmental conditions in the specific location of the lamp or group of lamps controlled by the ILCD.

Under these conditions, when the ILCD is located directly on the lamp and functions according to the program and schedule entered into it, that is, it works in automatic mode, regardless of the dispatcher, then there will be no LCD at the substation, and there will be no lamp control channel in the control scheme. ILCD functions independently of the dispatcher and substation and executive equipment.

The advantages of the mixed management of external road lighting over the centralized one is that it ensures the guaranteed functioning of each individual lamp or group of lamps, in accordance with the given schedule and specific local environmental conditions. At the same time, a significant increase in the cost of EPPS and the lamp as a whole is a significant disadvantage of the mixed outdoor lighting control system.

The ZSCZO has the following disadvantages:

- lack of feedback from the dispatcher;
- the need for maintenance personnel to control, maintain, and repair the luminaires;
- lack of ability to control outdoor lighting in specific conditions.

At the same time, as a significant advantage of MELCS (Fig. 2.12) over CRCOL and ZSCZO, there is the absence of a control channel for lamps, which involves the performance of significant volumes of work during installation, during repair and maintenance, and large amounts of monetary costs.

A reduction in monetary costs for MELCS is possible if one IPKS serves a group of lamps that are in almost the same conditions.

MELCS ensures the operation of the power supply channel and regulation of the light flux level from the lamps without a lamp control channel, which can be replaced by other means, without laying control channels, such as radio communication, by installing transceivers at the substation and in individual lamp control devices, installing PSL communication by using a wired line.

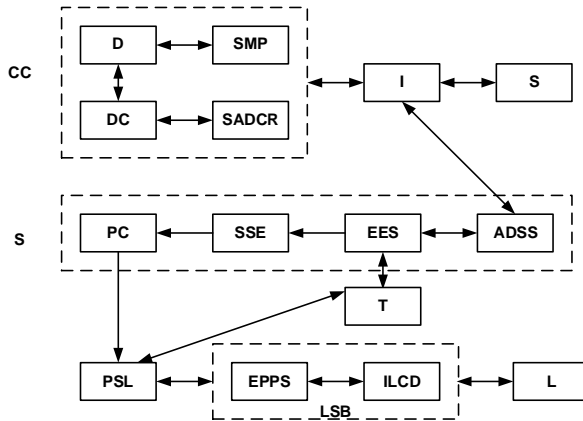

Figure 2.12 – Schematic diagram of the functioning of the mixed external lighting control system: CC – control center, D – dispatcher, DC – dispatcher's computer, ADSS – substation server access device, EES – executive equipment of the substation, SMP – maintenance and programming specialist, S – substation, ILCD – an electronic power source with an individual lamp control device integrated into it, SSE – substation switching equipment, S – server, I – Internet, PC – power contacts, PSL – power supply of lamps, EPPS – electronic pulse power source, L – lamps, T – transceiver

That is, the receiving-transmitting device is integrated into the executive equipment of the substation and into the group device for controlling the lamps in the power supply unit and controlling their modes of operation, providing feedback from the GLCD to the EES through the electrical power supply network of the lamps, with subsequent output to the server and the dispatcher's computer through the Internet (Fig. 2.13).

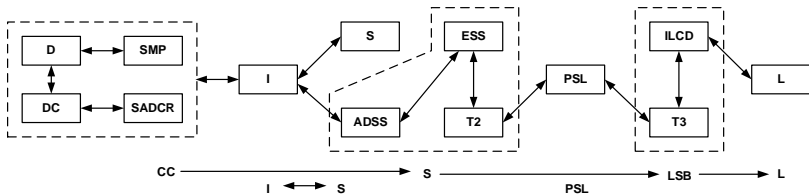

Figure 2.13 – Information transfer scheme from the system power supply unit control of lamps to the dispatcher's computer

That is, two methods of information transmission are used to transmit information from the control room to the lamps or from the lamps to the

control room:

1) between CC and S, information is transferred via the Internet and the server;

2) between S and LSB, information transmission is carried out through the power supply network of the lamps, using transceivers integrated into the EES and EPPS, or made as a separate device placed in the lamp housing.

The transmission of information between the substation and the power supply and control unit can be carried out either through PSL, through frequency conversions in T, or through the radio channel from EES to EPPS with output to ILCD (Fig. 2.14).

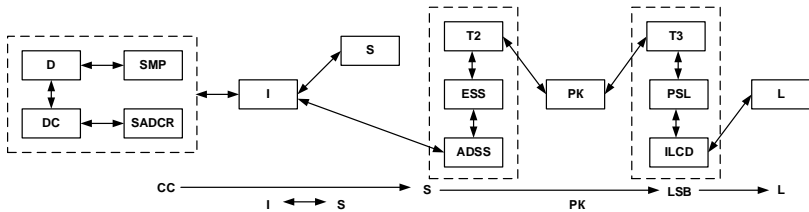

Figure 2.14 – Scheme of transmission of control signals from the substation (power points) to the lamps via the radio channel

If the EPPS is additionally equipped with a microcontroller and a system for monitoring the environment, that is, according to the state of atmospheric pollution, temperature, pressure, air humidity, road lighting, the intensity of traffic at night, then it is possible to effectively control the light flux of LED lamps by LSB, ensuring a minimum electricity consumption, i.e. the maximum level of savings in monetary costs for road lighting at night and efficient consumption of electrical energy by lighting installations.

Of course, additional equipment for the outdoor lighting control system involves additional material and financial costs, which should be reasonable and cost-effective at the moment.

2.6 To the process of integration of means of accumulation of electrical energy into variants of synergistic structures of power supply systems with external lighting

As noted in the research materials of the previous sections, in today's realities, the most effective direction in the development of EL complexes of streets and areas of populated areas is the use of synergistic types of PSS

structures with their arrangement as autonomous generating sources and EE accumulators.

During the period of a number of scientific studies [26, 108-115], a number of interesting projects for the use of EE storage devices in PSS EL structures were presented.

However, the provision of unified recommendations for specific types of generation sources and EE storage devices, based on the application format, is not a logical and appropriate statement regarding the locations of these facilities on the PSS map of EL sources in specific blocks of their formation. Both of the above criteria should be determined by the specific structure of the PSS scheme, the landscape of the area, environmental requirements, etc.

One thing is certain about this, that the PSS scheme of the external lighting network is a component of the general electric power structure of a specific settlement and it must logically form into this structure, filling and supplementing it with the features of compliance with the regulatory specifics of structuring.

At the same time, we note that the selection and evaluation of the effectiveness of the application of certain PSS EL structures is a task of a scientific research level, but the selection of EE generation and accumulation measures in justified power supply schemes is, rather, an engineering task.

Solar and wind energy are among the main types of renewable EE sources that can be used in residential EL systems. That is, it provokes the variability of the construction of the corresponding PSS with the inclusion in their structure of autonomous mini-power plants, that is, power supply systems with distributed EE generation (Fig. 2.15).

One of the features of the operation of such mini (micro) power plants in PSS EL structures is that their use of relevant energy resources leads to a certain discrepancy (imbalance) between the levels of generation and consumption of electricity, which is due to the uneven nature and stochasticity of the process of their accumulation, according to weather conditions, the necessary volume of EE for its further consumption by the EL complex.

So, for example, at solar power plants, the maximum power that can be produced during a daylight day is provided on the condition that the day was cloudless, and maximum insolation of the working surface of the solar panel will be provided.

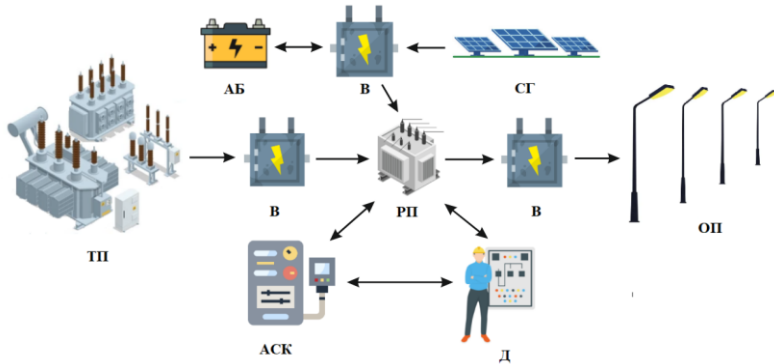

Figure 2.15 – Simplified structure of the outdoor lighting control option: TS – transformer substation; DP – distribution point; SMEP – solar micro-electric plant; RB – rechargeable battery; Sw – switches; ACS – automated control system; D – dispatcher; LD – lightning devices

At wind farms in adverse wind conditions, when the wind speed is outside the minimum or maximum limit value of the EE generation range and sufficient to start the wind turbine, no electricity will and cannot be produced at all.

That is, forecasting the levels of EE generation in such cases is impossible and an appropriate adaptive response of the system to these cases is required to ensure sufficient performance and reliability of the entire PSS EL.

In this direction, it is expedient to add electric energy accumulators to their structure in order to reduce output power fluctuations in such variants of synergistic PSS EL based on various solar and wind mini-power plants. As a rule, secondary electromechanical current sources characterized by the property of multiple recharging are used as such storage devices: batteries, capacitors, etc.

At one time, and for a considerable period of years, the use of lead-acid RB in energy systems of renewable energy was very popular [115]. However, in recent times, they have been supplanted by modern types of batteries built on lithium and related technologies in terms of discharge-charge, energy and compact characteristics. This is due to the fact that RBs based on lithium technologies have a number of advantages over other types of batteries that are in use today. Among other characteristics that influence the popularity of these types of RB, higher density, power, smaller dimensions and their optimal cost should be singled out. Also, taking into

account the stochasticity of the generation levels of renewable energy sources and the changing, not always linear schedule of consumption, EE EL, it is worth noting the "memory effect", which is absent in the data of RB types, which increases the effective use over a long period of time.

However, during the operation of these types of RB, like all others, there are also their own shortcomings and peculiarities. Therefore, during their operation, attention should be paid to the following features of the functioning of these types of storage batteries, such as: operating voltage, which is from 3.7 to 4.2 V, inadmissibility of overheating, non-recoverable loss of capacity when discharging to a voltage below 2.7...3 V, accelerated degradation at overcharging above 4.2 V, as well as the limited capacity of an individual battery. Therefore, in order to create the necessary storage capacities, including at autonomous power plants, lithium batteries are necessary and, as a rule, combined into series-parallel assemblies – RB complexes [115].

The main condition for this variant of creating the necessary storage capacities on the basis of storage assemblies is the use of batteries of the same type and with the same or slightly different parameters.

For reliable operation of the battery assembly, all included elements must have the same level of voltage and capacity. The presence of at least one element with excellent parameters will lead to premature full discharge of this or that battery below the permissible voltage level, which will lead to a non-recoverable loss of capacity, or an excess of the maximum voltage level during charging, which, in turn, will cause this battery to overheat and its thermal destruction. As a result, the load on other accumulators in the assembly increases in the future, which will lead to an acceleration of the discharge and a decrease in the output voltage of the general energy storage system as a whole in the accumulator complex. This will significantly reduce the efficiency of the storage power plant, because the charging rate of the batteries by the generating equipment may be lower than the intensity of their discharge. The resulting reduction in the output voltage of the energy storage system will also reduce the efficiency of the power conversion by the inverter through which the consumer receives power. Also, a situation may arise when the voltage in the direct current link falls below the permissible level, and the conversion with the transfer of power to the network stops altogether.

In addition to RB, in the role of effective EE accumulators for PSS EL conditions, capacitors can be used – supercapacitors, the designs and corresponding energy parameters of which have been intensively improved in recent years. An important touch for a positive solution to the problems of EE accumulation in PSS EL structures with distributed generation is that

small-sized conditions in this case do not play a role in the system-forming definition. The existing premises of transformer substations and distribution points analyzed by PSS have the appropriate potential for installation of EE storage facilities in them. An example of a calculation for determining the electrical parameters of the elements of autonomous sources of generation and accumulation of EE in the PSS variant of distributed generation is presented.

Conclusions to section 2

1. The analysis and subsequent formalization of the factors affecting the efficiency of the functioning of electric power complexes of outdoor lighting in populated areas allows to determine the logic of the management development of such systems with the possibility of complex multi-functional control of the lighting process.

2. The proposed approach to the modernization of electrotechnical complexes of outdoor lighting, based on LED light sources and a modern approach to the need to develop an intelligent control system, will allow to increase the efficiency of the functioning of street lighting systems both in the levels of light output and in the levels of energy efficiency.

3. The integration of electric energy storage elements into the power supply structures of outdoor lighting complexes in synergistic versions of lighting networks of populated areas will make it possible to solve the problem of uninterrupted power supply complexes of lighting networks.

CHAPTER 3.
ANALYSIS AND DEVELOPMENT OF THE
ELECTROTECHNICAL COMPLEX OF OUTDOOR LIGHTNING

3.1 Modeling of the process of controlling the electrotechnical complex of outdoor lighting

The creation and implementation of outdoor lighting management in the modern vision of the efficiency format of the final solution a priori involves the use of complex equipment, and the methods of forming control systems are not simple and involve significant costs.

The development process of the formation of EL control schemes determines the need for an applied theory of analytical problem solving, which is focused on their effective use in RCSOL complexes.

The main principles of the applied theory of the development of structures and functional capabilities of RCSOL can be:

- a comprehensive approach to the analysis of the proposed models and methods of EL management at all its stages;
- a systematic in-depth analysis of the impact on the level of luminous flux of lamps of all available factors (traffic intensity, road lighting, weather conditions, atmospheric pollution, etc.);
- provision of minimal material and financial costs in the development of the EL road remote control system;
- formation of the most effective EL road management system and its software.

Adherence to these principles should ensure the application of theoretical methods and control algorithms of RCSOL and perform modeling of such a lamp control system, applying the methods of the theory of inverse problems of dynamics, variational calculus, optimal control, mathematical programming, the theory of intelligent control and other scientific disciplines. And the system of mathematical expressions that characterize the lamp control system are called mathematical models of EL control at different time intervals [44].

In vector form, the mathematical model of control of the electrotechnical complex EL can be written as follows:

$$\dot{X} = f(\Phi, u, t), \text{ if } t \in [t_0, t_m], \Phi(t_0) = \Phi_0; X(t_0) = t_0 \quad (3.1)$$

where $[t_0, t_m]$ – the time interval during which EL of the road is carried out;

- t_0 – the moment of turning on the lights;
 t_m – the moment of turning on the lights;
 Φ – luminous flux from lamps;
 $\Phi = (\Phi_1, \Phi_2, \dots, \Phi_n)$ – light flux level vector;
 $u = (u_1, u_2, \dots, u_m)$ – control vector;
 $f = (f_1, f_2, \dots, f_n)$ – vector function of its arguments,
 $x = (x_1, x_2, \dots, x_n)$ – the state vector of the lamps.

Moreover, such restrictions are placed on the control signal that u_{\min} corresponds to Φ_{\min} , and u_{\max} corresponds to Φ_{\max} , i.e

$$u_{\min} \leq u(t) \leq u_{\max}, t \in [t_0, t_m] \quad (3.2)$$

Arguments, they are factors on which the level of luminous flux Φ from lamps depends:

- E – road illumination;
 M – luminosity of other light sources at night;
 K – traffic intensity on the road;
 $x = x(t), y = y(t), z = z(t)$ are the coordinates of the lamps in the

Cartesian coordinate system, with the center at the location of the substation S of the corresponding control room CC [45].

Then the phase vector of the light flux level has the following characteristic coordinates: $E(t), M(t), k(t), x(t), y(t), z(t)$.

The initial conditions for this system of differential equations will be the following expressions:

$$E(t_0) = E_0; M(t_0) = M_0; k(t_0) = k_0; x(t_0) = x_0; y(t_0) = y_0; z(t_0) = z_0.$$

Then the system of differential equations can be written in the following form:

$$\begin{cases} \dot{E} = f_1(E, M, k, x, y, z, u), t \in [t_0, t_m] \\ \dot{M} = f_2(E, M, k, x, y, z, u) \\ \dot{k} = f_3(E, M, k, x, y, z, u) \\ \dot{x} = E \cos M \cdot \cos k \\ \dot{y} = E \sin M \\ \dot{z} = E \cos M \cdot \sin k \end{cases}, \quad (3.3)$$

The generated control vector $u(t)$ is estimated by substituting into the system of differential equations and modeling the level of light flux Φ from the lamps by numerical integration under the given initial conditions.

To characterize the EL remote control of roads at night, you can use the formal EL control, which can be generally characterized by a vector system of differential equations of the following form:

$$\dot{x} = f(x, t, S), t \in [t_0, t_m], x(t_0) = x_0 \quad (3.4)$$

where S – the set of control commands.

$S = \{S_1(a), S_2(a), S_3(a) \dots S_m(a)\}$, where $S(a)$ – the name of the j -th control command (number and digital code), where $j = (1, \bar{m})$, a – vector of parameters that characterizes the required level of light flux Φ , with the specified control commands.

At each moment of time $t \in [t_0, t_m]$, there should be only one control command $S_j(a)$, $j = (1, \bar{m})$ in the right-hand side of the differential equation $\dot{x} = f(x, t, S)$.

In order for EL control to be performed by only one command at each moment of time, let us consider the Boolean function $w_j(t)$, which has the form [116]:

$$w_j(t) = \begin{cases} 1, & \text{якщо } t \in [\tau_j, \tau_{j+1}] \text{ нпу } S_j(a) \in S; \\ 0, & \text{якщо } j = (1, \bar{m}) \text{ нпу } S_j(a). \end{cases} \quad (3.5)$$

Execution at each moment of control of the luminous flux of the lamp is formed as follows:

$$\sum_{j=1}^m w_j(t) = 1, t \in [t_0, t_m]. \quad (3.6)$$

Then, the model for controlling the luminous flux EL of roads at night can be written as follows:

$$\dot{x} = f\left(x, t, \sum_{j=1}^m S_j(a) w_j(t)\right), t \in [t_0, t_m], x(t_0) = x_0. \quad (3.7)$$

The selection of the control signals of the EPPS lamp acts as a selection on the time interval $[t_0, t_m]_A$ of the functions $w_1(t), w_2(t) \dots w_m(t)$ that satisfy the EL control conditions.

3.2 Modeling and research of the operation of the lighting installation control system

In fig. 3.1 shows the structural diagram of the lighting system, which consists of a controller, a battery, a photovoltaic module, a motion sensor, and LED floodlights.

The structure of the energy system of the lighting system with sources of distributed generation is as follows: the primary converter of solar energy into direct current electrical energy – the converter of direct current electrical energy into alternating current electrical energy, or the converter of wind energy into electrical energy.

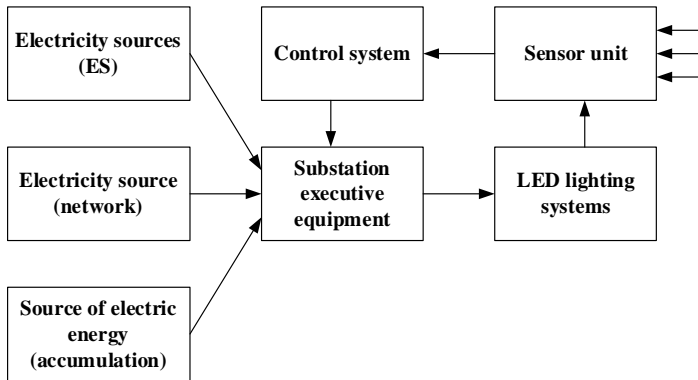

Figure 3.1 – Structural diagram of the lighting system

The selected lighting system, based on a solar energy installation, consists of a primary converter of solar energy into direct current electrical energy and a regulating device (controller) [117].

Such a street lighting system can work completely autonomously. The advantages of these systems are the possibility of installation on any terrain, where it is not even possible to run a cable or overhead power line.

Let's calculate the nominal values of the laboratory complex for researching the energy characteristics of the proposed lighting control system (Fig. 3.2).

To calculate the elements of the system, we assume the capacity of the battery $ca=60$ A-hours, designed for an operating voltage of 12 V, if a current of $I = 2$ A, is consumed daily from the battery for $\tau=8$ hours, provided that the voltage of one silicon solar cell at maximum load is $U = 0,442$ V, and

the current density on it is $j=2 \cdot 10^{-2} \text{ A/cm}^2$.

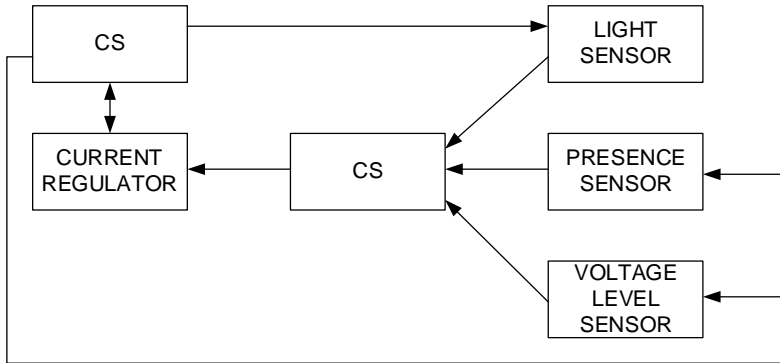

Figure 3.2 – Structural diagram of the laboratory complex for researching the functioning of the lighting regulation system

Let's calculate the voltage of the solar panel, which is necessary to charge the battery to a voltage of 12 V according to the formula [120, 121]:

$$U = 1,25 \cdot U_{ok}, U = 1,25 \cdot 12 = 15 \text{ V.}$$

Let's determine how many silicon solar cells must be connected in series so that the voltage of the solar panel is at least 15 V, according to the formula [118, 119]:

$$n_{el} = \frac{U_c}{U_{ok}}, n_{el} = \frac{15}{0,442} \approx 33,94 \approx 34 \text{ elements.}$$

Let's calculate the daily consumption of electric energy from the battery by consumers according to the formula [118, 119]:

$$C_{acc} = I \cdot \tau, C_{acc} = 2 \cdot 8 = 16 \text{ A} \cdot \text{h.}$$

Let's calculate the amount of energy that must be used daily from the solar panel according to the formula [118, 119]:

$$C_c = C_{acc} \cdot \frac{U_c}{U_{acc}}, C_c = 16 \cdot \frac{12}{15} = 20,0 \text{ A} \cdot \text{h.}$$

Since silicon solar cells are illuminated by the sun's rays every day for 5 hours, the required current for charging the battery can be calculated using the formula [120]:

$$I_c = \frac{C_c}{\tau_c}, I_c = \frac{20}{5} = 4 \text{ A.}$$

We find the area of the solar panel from which the charging current I_c

can be obtained when the elements are connected in series according to the formula:

$$S_p = \frac{I_c}{j}, S_p = \frac{4}{2 \cdot 10^{-2}} = 200 \text{ cm}^2 = 2 \cdot 10^2 \text{ cm}^2.$$

Let's calculate the area of one silicon element [121]:

$$S_{el} = \frac{S_p}{n_{el}}, S_p = \frac{200}{34} \approx 5,88 \text{ cm}^2 \approx 5,9 \text{ cm}^2.$$

The radius of one silicon element is determined by the formula [121]:

$$R_{el} = \sqrt{\frac{S_{el}}{\pi}}, R_{el} = \sqrt{\frac{5,9}{\pi}} \approx 1,4 \text{ cm}.$$

The size of the solar panel when the elements are connected in series in two rows of 17 pieces will be equal to:

a) panel length $a = 17 \cdot 2 \cdot 1,4 \approx 46,5 \text{ cm}$,

b) panel width $pw = 4 \cdot 1,4 \approx 5,5 \text{ cm}$.

The serial connection of 34 silicon solar cells with a radius of 1.4 cm will ensure the charging of the battery during 5 hours of solar illumination of the panel daily [121].

The conducted analysis of NiCd, NiMh, Pb, and Li electrochemical systems shows that the option of using *Li*-ion storage batteries is optimal for a solar power plant [57].

Thus, we select a battery for 60 A·h, fuses for 10 A, and a LED module for 60 W.

Installation of LED floodlights will illuminate the carriageway of highways on stretches between two lighting poles. The installation of motion sensors will allow the lamp to be turned on only in the presence of a person and a vehicle, which will lead to a decrease in the power of the installed photovoltaic module and the RB capacity.

The graph of the dependence of the luminous flux has a typical form for LEDs (Fig. 3.3), where at the initial stage the dependence between the linear character and the luminous flux increases with an increase in the value of the direct current.

In the central part, the dependence changes its character, and the luminous flux begins to decrease with the increase of the electric load, which is associated with the heating of the active region of the crystals and is explained by the increase in the fraction without radiative recombination of carriers in the LED material.

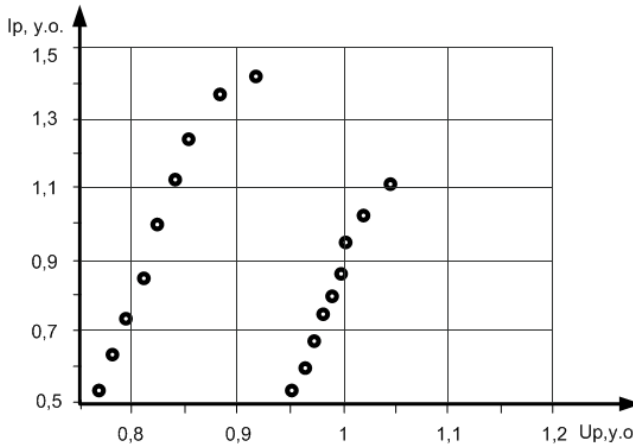

Figure 3.3 – Dependence of the current-voltage characteristic of lighting systems on the supply voltage

Meanwhile, as shown in fig. 3.4, the luminous flux of an LED light source depends almost linearly on the regulation of the control current. At the same time, it should be noted that when the control current increases above the nominal value, the luminous flux begins to decrease, which is due to the heating of the active region of the crystals.

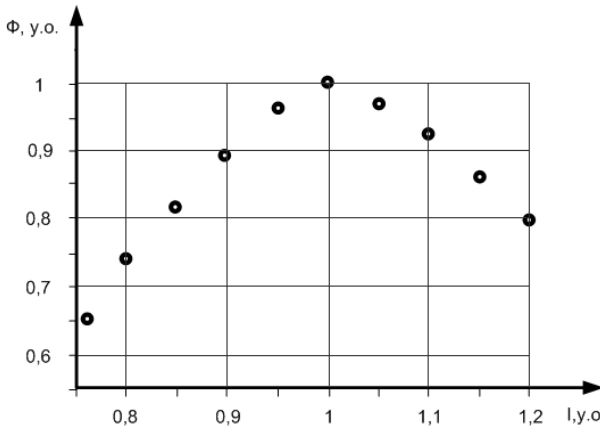

Figure 3.4 – Dependence of the luminous flux on the control current

So, the dependence of the output current of the control system on the

network voltage (Fig. 3.5) is shown as proportional, which ensures the efficient operation of the lighting system.

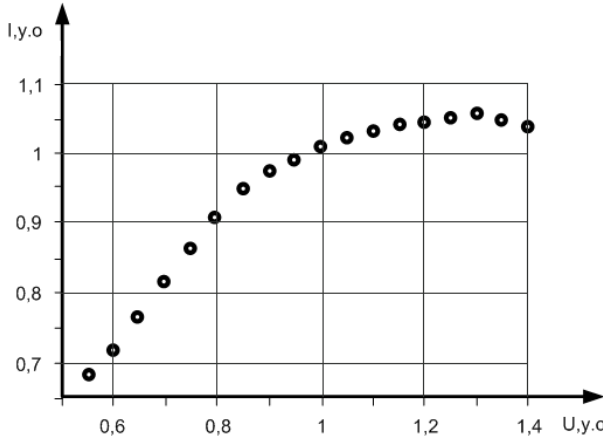

Figure 3.5 – Dependence of the output current of the control system on the network voltage

The dependence of the efficiency (Fig. 3.6) on the network voltage at a constant load shows the optimal values of the coefficient of useful action in the range of values of 0.75-1U.

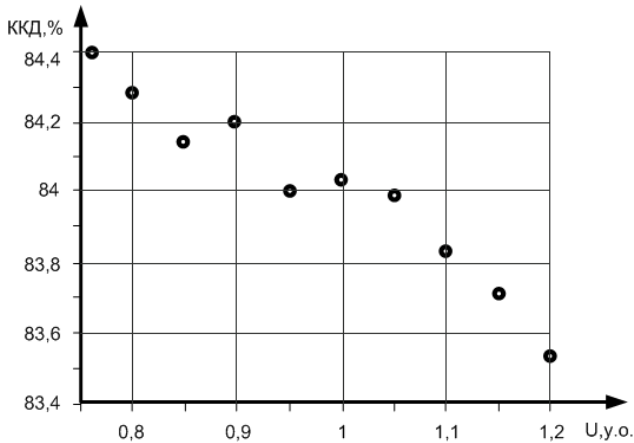

Figure 3.6 – Dependence of the efficiency factor on the network voltage at a constant load

In the program DIAL.ux version 4.9, the street lighting system of the settlement is designed (Fig. 3.7).

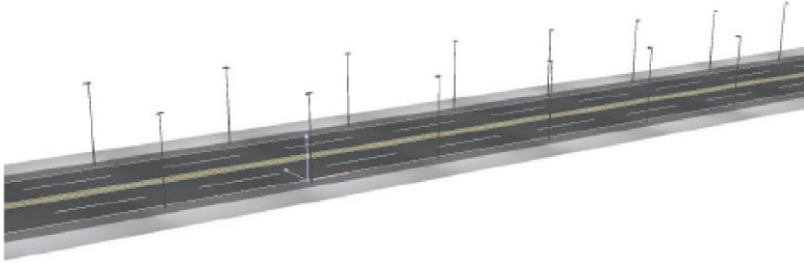

Figure 3.7 – Project of the street lighting system of the settlement

The results of simulation of the operation of the control system showed that the lighting control system has optimal performance when the lighting is reduced or increased and provides lighting of the streets of populated areas at a sufficient level (Fig. 3.8 and Fig. 3.9).

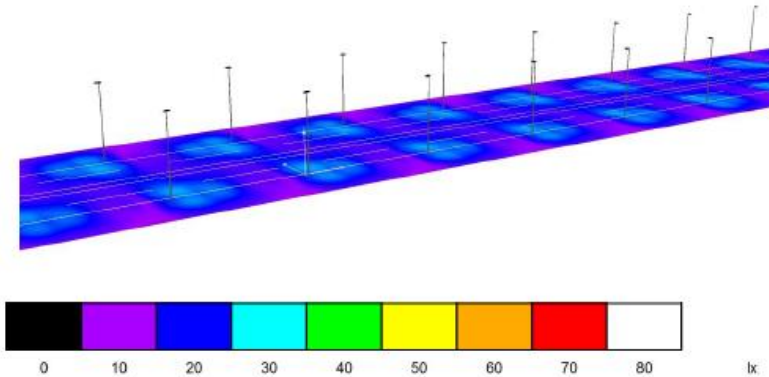

Figure 3.8 – Results of modeling the operation of the lighting control system with increasing illumination

Obviously, the control system is sufficiently stable on the load voltage control channel, which indicates the possibility of high-quality control of street lighting in populated areas.

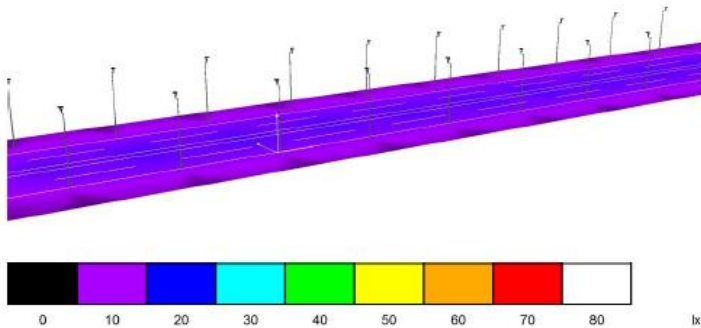

Figure 3.9 – The results of modeling the operation of the lighting control system when the illumination is reduced

A slight discrepancy between theoretical and experimental data confirms the adequacy of the developed models. The total measurement error of the informative parameters of the control system does not exceed 10% and will not significantly affect the quality of control.

3.3 Modern aspects of building intelligent electrical networks

According to the definition provided by the US Department of Electric Power, an "intelligent" electrical grid is a fully automated system that provides a two-way flow of electrical energy and all necessary information between energy facilities throughout the area where it is deployed [122].

In the countries of the European Union, this term should be understood as such an electric network that meets all the requirements of energy-efficient and economical functioning of the energy system through coordinated management and through bilateral interaction between the elements of the electric network – power plants, sources and accumulators of electric energy and its consumers [123].

According to the definition of NETL (The National Energy Technology Laboratory USA), an "intelligent" electrical network is a set of organizational changes, a new process model, solutions in the field of automated process control systems and dispatch control in electric power [124].

However, in the opinion of most scientists, the general and technically complete definition of the mentioned concept was proposed by the team of scientists of the IEEE Institute (The Institute of Electrotechnic and Electronic Engineers), according to which it is a fully integrated self-regulating and self-healing electric power system that has a network topology and includes all

sources generation, trunk and distribution networks and all types of electricity consumers, which are managed using a single network of information management devices and systems in real time [125].

The concretization of the concept of Smart Grid in relation to electric power systems of different technical levels initiated the appearance of such terms as Strong Smart Grid (SSG) – voltage networks above 110 kV, Regional Smart Grid (RSG) – voltage from 3 to 110 kV and Micro Smart Grid (MSG) – voltage of 0.4-3 kV, characteristic directly of the systems themselves and arising when they are combined, which determines the peculiarities of the construction of the equipment in the nodes of their connection and in the nodes of the connection of loads [126]. The practical solution of the listed tasks can be carried out on the basis of the use of power electronics and, in particular, on the basis of the wide implementation of converters of electrical energy parameters.

The choice of the type and all structural elements proposed for use in intelligent networks should be carried out taking into account the nature of the change in the electrical energy parameters characteristic of a particular system. The main features of the SSG, RSG and MSG systems are the significant difference in the change of their electrical energy parameters over time. Thus, relatively high stability of energy parameters is characteristic of SSG systems. In RSG-systems, there is some, and sometimes significant, change in the parameters of electrical energy, due to the type of connected load and the power of the transformed substations [127].

Meanwhile, the current trends in the development of world energy are aimed at the modernization of electrical networks, including MSG. In most cases, this manifests itself in an increase in energy efficiency, stimulating the development of alternative and renewable energy, increasing the level of automatic optimization and control of electrical networks, improving relay protection, etc.

Modern trends in energy development are aimed at a gradual transition to a fundamentally new solution, which is focused on the widespread use of distributed energy sources and active networks capable of providing services for the transmission and storage and conversion of electrical energy. Active electricity networks are able to quickly adapt to the changing needs of energy market stakeholders. To date, all aspects of creating "smart" energy systems are considered in the concept of Smart Grid, the best-known concept of modernization of electric networks. This concept is characterized by two-way flows of electricity and information to create an automated, widespread distribution network. The exchange of information takes place between the communication sources of generation, transmission, distribution and

consumption of electricity, which are physically represented by automation and production control systems of each of the domains. Also, this concept provides for the implementation of current control, protection and optimization of the functioning of all interacting elements, which include powerful generators and renewable energy sources, which are connected to electricity consumers, electricity storage facilities, and end consumers with the help of trunk and distribution networks [127].

It should be noted that Smart Grid is not only new energy technologies, but also modern information and communication technologies of e-commerce, access control and administration in networks of various scales, data modeling and storage, collection, processing and transmission of information in real time. Thus, Smart Grid should be considered not as a separate technology, but as a comprehensive approach and methodology for the creation of large-scale "smart" energy objects that function on the basis of a new technological platform and provide a wide range of services using information and energy technologies.

Meanwhile, experts believe that the application of modern control technologies, along with the wide use of the latest information and communication technologies, will make it possible to maintain demand and supply at the level of a separate energy device in "smart" energy systems. SmartGrid will allow consumers to consciously participate in the functioning of energy systems, while the use of assets in the energy sector will improve, economic efficiency will increase, the quality of electricity will increase, and the resistance of energy systems to unauthorized external influences will increase [126].

For reliable and high-quality electricity supply to consumers, power systems must have capacity reserves, which include such types as load, national, emergency, and repair.

3.4 Algorithm of the system of intelligent control of the level of street lighting

The logistics of intelligent control of the lighting system includes the corresponding control subsystem – the lighting level monitor.

The subsystem of intelligent control of the level of street lighting works according to a predefined work algorithm (Fig. 3.10), which is set by software after installing the system.

The EL intelligent control system is a solution for remote control of outdoor lighting, which has the ability to control the operation of electric light sources and the level of their consumption of electric energy, according to the

real level of illumination of a given area.

Also, the proposed control system guarantees the illumination of a given area under various operating conditions around the clock. Equally important is the fact that there is feedback in real time, which reports on any changes occurring along the line or section, reducing the loss of electrical energy. Thus, even if some lamps on the line fail, the control system will try to perform the task of normalized lighting of a certain area.

The intelligent EL control system works at any time, thereby helping to almost completely avoid the risk of emergency situations in the lighting network due to a malfunction of the lighting system.

As an additional function of this control system, it is possible to adjust the decorative lighting, which reduces the costs of building an additional control system.

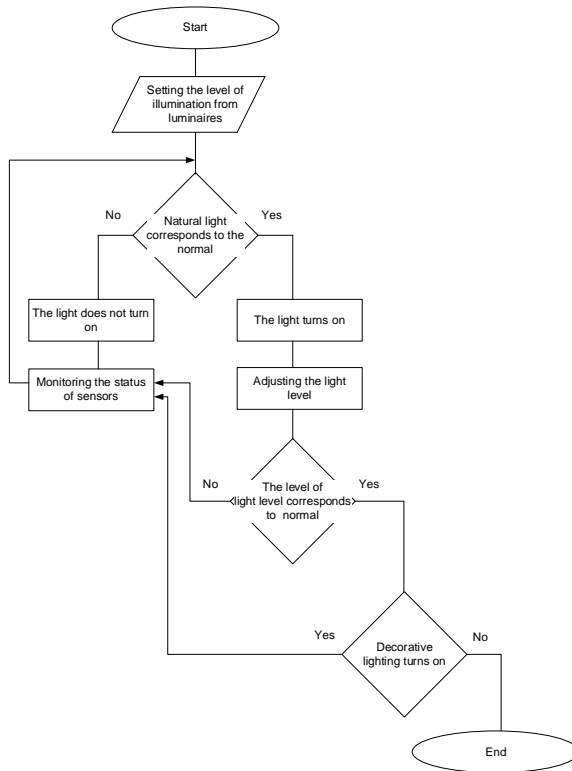

Figure 3.10 – Algorithm of operation of the intelligent outdoor lighting control system

3.5 General principles of building a fuzzy control system of an electrotechnical complex of outdoor lighting

The system can be formalized in the form of fuzzy logical statements. Each statement can be rated with a vague degree of truth. Each such statement can be described using relations of sets of linguistic fuzzy variables.

A linguistic variable is a tuple of the following values $\langle \beta, T, X, G, M \rangle$, where

β – variable name (for example "illuminance");

T – a base set of values, each of which is represented by a fuzzy set (for example, "low", "medium", "high", "very high");

X – the carrier set of possible specific values of the variable for all sets (for example, $X = [0, 200]$ лк);

G – some synthetic procedure for generating new fuzzy sets from T (for example, "very small");

M – semantic procedure of providing a fuzzy set of a certain fuzzy variable of the form $\langle X, \mu_i(X) \rangle$, $\mu_i(X)$ – function of membership of the i -th fuzzy set in T.

The construction of a system of fuzzy logic inference (VLC), which is based on the use of the Mamdani algorithm, which allows to significantly reduce the amount of calculations, has the following stages [128]:

1. Designing the VLC rule base. Each rule is written in the form:

If <condition> **then** <conclusions> [rule validity measure]

For the Mamdani algorithm, <condition> and <conclusions> look like logical connections of the following entries: <fuzzy variable> = <value>

2. Entering these rules in VLC.

3. Using VLC to process input information in the form of specific values of input (fuzzy) variables. This stage, in turn, is divided into the following components:

3.1. Entering the values of the input variables. That is, some facts that are considered 100% true.

3.2. Fuzzification of input variables – establishing correspondence between a specific value of input variables and the value of its fuzzy set, together with a membership function.

3.3. Aggregation of complex conditions that are in the rules after the keyword IF, that is, determination of the degree of truth of all conditions in all rules, if the conditions are provided using complex logical expressions. The rule is activated if the truth of its condition is greater than zero. In

knowledge bases, the procedure for aggregating conditions in rules is performed with the help of fuzzy logical operations – fuzzy conjunction, fuzzy disjunction, fuzzy rejection, etc.

3.4. Activation of sub conclusions is the process of determining the degree of truth (belonging to the corresponding fuzzy sets) of the variables that are in the conclusions of active rules, according to the formula:

$c_k = b_k F_k$, where c_k – degree of truth of the conclusion of rule k , b_k – degree of truth of its condition, F_k – degree of truth of the rule itself (weight factor of the k -rule).

After the vector $C = (c_1, \dots, c_q)$ is determined, the membership functions for each of the sub-inferences for each output linguistic variable are determined. Suppose that the corresponding fuzzy set of the original linguistic variable is determined by the membership function $\mu(y)$. Then, after the activation procedure, we get the renewed membership function of the corresponding fuzzy set (subconclusion) $\mu'(y)$ according to one of the methods of fuzzy composition:

- min-activation: $\mu'(y) = \min\{c_i, \mu(y)\}$;
- prod-activation: $\mu'(y) = c_i \mu(y)$;
- average-activation: $\mu'(y) = 0.5(c_i + \mu(y))$.

Note that different sub conclusion rules may contain the same fuzzy sets of linguistic variables. In such cases, for each linguistic variable we define a set of different membership functions that are computed by one of the fuzzy composition rules per rule. The final membership function for this fuzzy set is defined next.

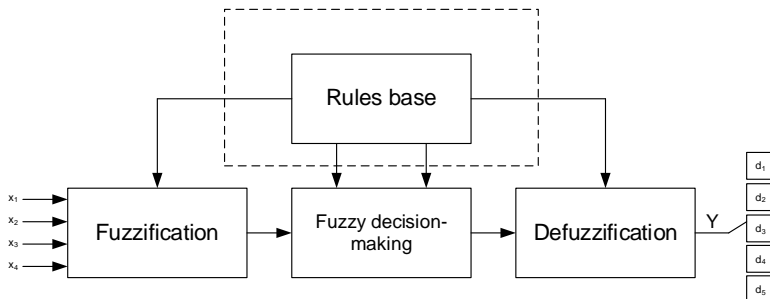

Figure 3.11 – Block diagram of fuzzy logic output

3.5. Accumulation of conclusions, that is, determination of the value of membership functions for fuzzy sets of all output variables. If a set of membership functions $\mu_1^i(y), \dots, \mu_p^i$ is defined for one linguistic variable, then the accumulation is performed according to one of the rules for combining fuzzy sets:

- association: $\mu'(y) = \max\{\mu_1^i(y), \mu_2^i\}$;
 - algebraic union: $\mu'(y) = \mu_1^i(y) + \mu_2^i(y) - \mu_1^i(y)\mu_2^i(y)$;
 - marginal union: $\mu'(y) = \max\{\mu_1^i(y) + \mu_2^i(y) - 1, 0\}$;
 - transaction λ -sums: $\mu'(y) = \lambda\mu_1^i(y) + (1 - \lambda)\mu_2^i(y)$, $\lambda \in [0, 1]$.
- $$\mu'(y) = \begin{cases} \mu_1^i(y), & \text{if } \mu_2^i(y) = 0, \\ \mu_2^i(y), & \text{if } \mu_1^i(y) = 0, \\ 1, & \text{else.} \end{cases} \quad (3.8)$$

3.6. Defuzzification of source variables, i.e., determination of specific values by membership functions of fuzzy sets, is determined by the center of gravity method for continuous and discrete fuzzy sets according to the formulas:

$$z = \frac{\int_{y_{\min}}^{y_{\max}} y\mu'(y)dy}{\int_{y_{\min}}^{y_{\max}} \mu'(y)dy}, \quad z = \frac{\sum_{i=1}^n y_i\mu'(y_i)}{\sum_{i=1}^n \mu'(y_i)}. \quad (3.9)$$

The lighting control system is implemented in the form of a Mamdani fuzzy logic block, which can be represented in the form of a structure shown in Fig. 3.11 [128].

The next step in creating a fuzzy mathematical model is to fuzzification the input values X according to fuzzy sets and obtain the fuzzy set X.

Having the measured input values X, using this model, we find a fuzzy set from which, after the defuzzification operation, using the center of gravity method, we obtain the value of the correction coefficient of the output control value [128].

According to the fuzzy inference algorithm, the next stage is the fuzzification process, where correspondence is established between each specific value of the input variable of the fuzzy control system and the

corresponding fuzzy set of the input linguistic variable. After the completion of this process, specific values of membership functions for all linguistic variables are set for all input variables [128].

Conclusions to section 3

1. The approach proposed for the first time to the construction of the intellectualization of the structures of the control system of the electrotechnical complex of outdoor lighting of populated areas allows the implementation of the basic principles of the Smart Grid concept into the practice of building street lighting control systems of populated areas.

2. Modeling with the help of the developed simulation model for controlling the outdoor lighting of populated areas using the proposed control system with the use of fuzzy inference showed a smooth regulation of the functioning of the lighting system, which is qualitatively different from the energy characteristics of perfect and existing control systems.

3. The proposed algorithm of operation of the intelligent outdoor lighting control system will not only ensure safe traffic conditions and pedestrian safety, but will also significantly improve the city's architectural, tourist and commercial products.

4. According to the calculation results of the current street lighting network, losses of electrical energy during its operation were determined, the results of which confirm the need to modernize the current street lighting systems.

5. A completed example of a practical choice of modern electrical equipment for the existing external lighting network with an intelligent control system allows to provide high-quality, efficient and reliable lighting of streets and roads in populated areas.

CHAPTER 4.

FUZZY CONTROL SYSTEM OF THE ELECTROTECHNICAL COMPLEX OF OUTDOOR LIGHTING

As it was already shown in point 2.1, at present, the control of external lighting (EL) is carried out almost in manual mode using simple algorithms.

Automation of EL control can ensure the adaptation of the illumination level of lighting devices to the changing conditions in which they must work, such as the time of day, weather features and pedestrian or vehicle traffic. Controlling the level of illumination reduces electricity consumption, which is an important aspect of the sustainable development of cities and towns.

The social component should not be rejected either. Automated control of lighting devices allows you to use light points only when there is a need for it, that is, even at those hours when previously EL was turned off completely, which leads to an improvement in the comfort of the city and makes it attractive to the population.

4.1 Justification of the choice of the control system of the electrotechnical complex of outdoor lighting

Given that the EL control task must take into account complex fuzzy relationships between input and output variables and represent the system's conclusions in terms of fuzzy values, in this case, Mamdani's VLC should be applied to system design. This enables fuzzy IF-THEN rules to be expressed, whereby the output linguistic variables in Mamdani VLC are described by fuzzy sets, unlike Takagi-Sugeno-Kang or Tsukamoto VLCs, where the output is linear or monotonic functions, respectively.

The general task of the work is to create a control system for the EL electrotechnical complex based on Mamdani's VLC algorithm with many inputs and outputs, which would, firstly, take into account, among others, the amount of the electricity tariff when generating control, and also provide a recommendation for choosing the power source of lighting installations for achieving a reduction in the level of electrical energy consumption by lighting network equipment.

We will analyze the operation of the system using the example of the road surface lighting unit for the passage of motor vehicles along Kostenko Street between the intersections of Kostenko – Heroyv ATO and Kostenko – Universitetsky Avenue in the city of Kryvyi Rih (Fig. 4.1).

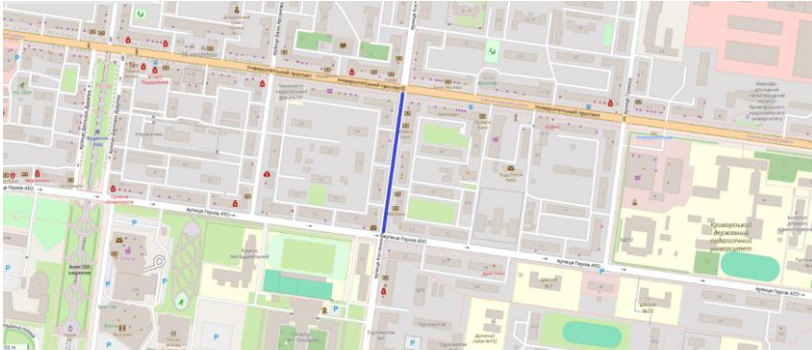

Figure 4.1 – Section of the road surface of the city of Kryvyi Rih, which is illuminated by LED lamps

The block contains 10 lighting installations along the street. Such a section of the road is typical for cities. During the day, the traffic on it is lively enough, and at night it is lonely. Cantilever LED lamps with two COB matrices with a total power of 100 W have already been installed on both sides of this road. The supply voltage is 230 V. The nominal current of the lighting device $I_{LED} = \frac{P}{U} = \frac{100 \text{ W}}{230 \text{ V}} = 0,435 \text{ A}$. The EL of a road, rather than a

pedestrian zone or yard, is more important considering the greater power and number of lighting installations per unit area of street-road networks. Taking into account the analysis of the literature, the inputs of Mamdani's VLC system will be lighting and traffic, to which the electricity tariff is added.

Control of light sources is implemented by the LED driver, which maintains a constant current on the LEDs and regulates the illumination by pulse-width modulation of the voltage. Since the driver of the LED lamp regulates the brightness of the PWM voltage, the first output of the control system will be "PWM switching". Given that the lighting installation can be powered either from the power grid or from batteries that store the energy produced by the solar panel during the day, the system must determine which power source is rationally used at the moment. Therefore, the second way out will be the "power source".

4.2 Development of a control system for the electrotechnical complex of outdoor lighting

In fig. 4.2 shows a fuzzy FCSEL outdoor lighting control system.

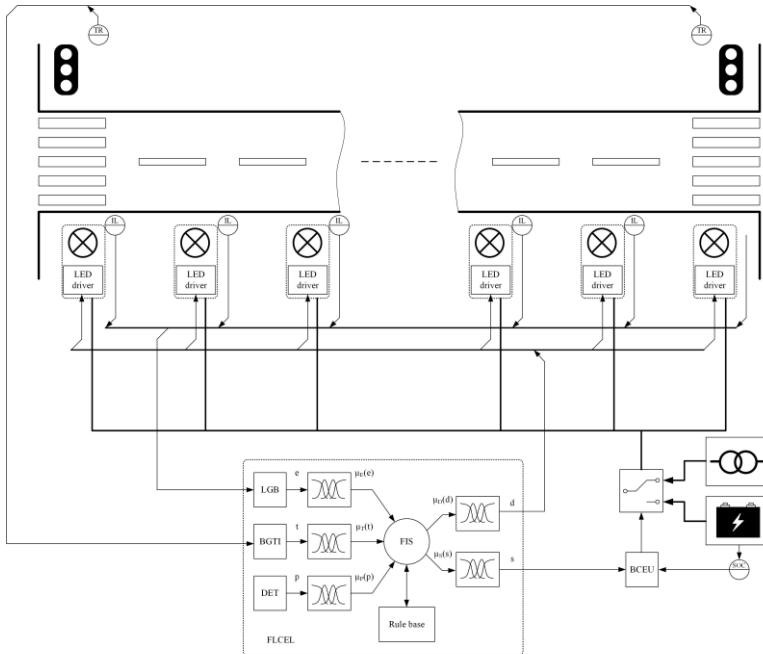

Figure 4.2 – Fuzzy outdoor lighting control system: LGB – lighting generalization block; BGTI – block of generalization of traffic intensity; DET – database of electricity tariffs; BCEU – battery charge evaluation unit; IL – light sensor; TR – traffic speed sensor

It contains the power part, which is represented by lighting devices with LED drivers, two power sources – the power grid and batteries (the latter are shown in general, since they can be both group and individual) and a switching device that switches one or another source to lighting installations ; the measuring part, which includes illuminance sensors (IL) near each LED lamp and traffic intensity sensors (TR) near traffic lights at both ends of the road; the control part, which is represented not only by Mamdani's FLC system, but also by sensor-derived illuminance information (LGB) and road traffic (BGTI) units, the electricity tariff database (DET) and the battery charge evaluation unit (BCEU).

FCSEL works like this. The values of illumination and traffic intensity measured by the respective IL and TR sensors are fed into the LGB and BGTI summarization blocks, which are then, together with the electricity tariff for

the given hour from the corresponding database (DET), transferred to the Mamdani FLC system. FLC is conducted, which gives the value of PWM switching for LED drivers of lighting devices and a recommendation for the use of a particular power source. If it is recommended to connect a battery, the battery charge evaluation unit (BCEU) determines the state of charge, if it is sufficient to power the lighting devices, the battery is connected, if not the FLC recommendation is ignored.

4.2.1 Fuzzification

The core of FCSEL is Mamdani's VLC system. The quality of control of the electrical engineering complex EL depends on it. Therefore, we will present the logistics of the stages of development of this part of the system.

The fuzzification of the functions belonging to the sets of the linguistic variable "enlightenment" (E) is carried out as follows. When designing an FCSEL, it is impractical to take into account illuminance levels that correspond to clear or cloudy days. Since in this version there is no need to use lighting installations. EL must be turned on at dusk. In [129], the values of illumination for different times of the day are shown. A value of 10 lk corresponds to twilight, and 100 lk to a very cloudy day. The illuminance at which it is necessary to illuminate the roads should be somewhere between these two values, therefore 50 lk is accepted. On the other hand, illuminance can be close to zero, but cannot be negative. So let's limit the finite set E to the values of $0 \leq e \leq 100$ lk. Let's highlight four vague sets here: "very gloomy day", "standard lighting", "twilight", "full moon". The average values for the membership functions of these sets are taken from [129] and are 50, 20, 10, and 0.267 lk, respectively. Standardized lighting for roads is adopted according to the requirements of DBN V.2.5-28:2018 "Natural and artificial lighting" [130]. Graphs of membership functions (Table 4.1) are shown in Fig. 4.3 a.

Table 4.1 – Functions of belonging to sets of the variable "Illumination"

Vague plural	Membership function type	Membership function
«A gloomy day» (OD)	Sigmoid	$MF_{OD}(x a=0, 2, c=50) = \frac{1}{1 - \exp[-0,2(x-50)^2]}$
«Normalized lighting» (NR)	Gauss	$MF_{NR}(x \sigma=7, \hat{x}=20) = \exp\left[\frac{-(x-20)^2}{2 \cdot 7^2}\right]$

«Twilight» (TW)	Gauss	$MF_{TW}(x \sigma=7, \hat{x}=10) = \exp\left[\frac{-(x-10)^2}{2 \cdot 7^2}\right]$
«Full Moon» (FM)	Gauss	$MF_{FM}(x \sigma=7, \hat{x}=0,267) = \exp\left[\frac{-(x-0,267)^2}{2 \cdot 7^2}\right]$

It is impractical to additionally use the illuminance values from [129], namely such as “deep twilight” (1 lk) or “starlight” ($2 \cdot 10^{-3}$ lk), due to the almost complete coincidence of the average values of the membership functions, which in the considered illuminance limits leads to their insignificant difference and can cause ambiguity in establishing the membership of measurement results to fuzzy sets at FLC.

When controlling lighting, it is necessary to take into account the presence of vehicles or people in the area of action of the lighting installation. The approach is quite common, when individual control of lamps is carried out when the presence of objects is detected. At the same time, with this approach, a frequent change in the level of illumination by light points is possible due to the constant appearance or disappearance of objects. In the case of a highway, this can cause visual discomfort, overstrain drivers and lead to an accident.

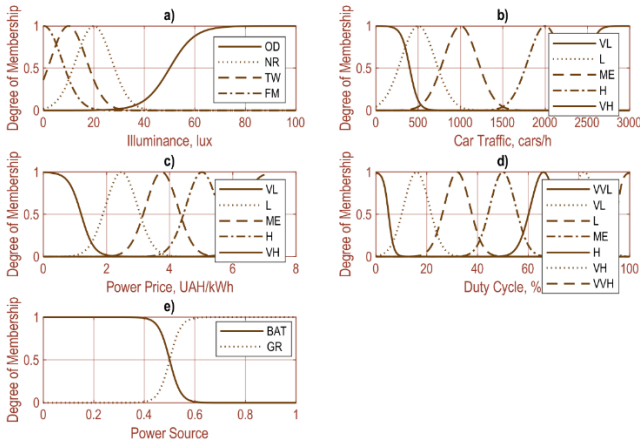

Figure 4.3 – Functions of belonging to sets of variables: a) "illumination"; b) "vehicle traffic intensity"; c) "tariff not electric energy"; d) "PWM controller switching" e) "power source"

Therefore, it will be more appropriate to use the traffic intensity

between two traffic lights or two intersections as a control action. That is, to carry out block control of lighting installations. When fuzzifying the linguistic variable "vehicle traffic intensity" (**T**), we will use the requirements for lighting streets and roads with regular traffic from DBN V.2.5-28:2018 "Natural and artificial lighting" [130]. We limit the finite set T to the values of $0 \leq t \leq 3000$ auto/hour. It will be described by five fuzzy sets: "very high intensity" (VH), "high intensity" (H), "medium intensity" (ME), "low intensity" (L), "very low intensity" (VL). Their average values are 400, 500, 1000, 2000, 2500 cars/hour. Graphs of membership functions (Table 4.2) are shown in fig. 4.3 b.

Table 4.2 – Functions of belonging to sets of the variable "Intensity of motor vehicle traffic"

Vague plural	Membership function type	Membership function
«Very low intensity» (VL)	Sigmoid	$MF_{VL}(x a = -0,02, c = 400) =$ $= \frac{1}{1 - \exp[-(-0,02)(x - 400)^2]}$
«Low intensity» (L)	Gauss	$MF_L(x \sigma = 200, \hat{x} = 500) = \exp\left[\frac{-(x - 500)^2}{2 \cdot 200^2}\right]$
«Medium intensity» (ME)	Gauss	$MF_{ME}(x \sigma = 200, \hat{x} = 1000) = \exp\left[\frac{-(x - 1000)^2}{2 \cdot 200^2}\right]$
«High intensity» (H)	Gauss	$MF_H(x \sigma = 200, \hat{x} = 2000) = \exp\left[\frac{-(x - 2000)^2}{2 \cdot 200^2}\right]$
«Very high intensity» (VH)	Gauss	$MF_{VH}(x a = 0,02, c = 2500) =$ $= \frac{1}{1 - \exp[-0,02(x - 2500)^2]}$

To simplify the linguistic variable "electricity tariff", we will analyze the current state of the issue of settlements between electricity supply companies and consumers. Today, a system of hourly changes in the electricity tariff is in effect. The company places an order for the amount of capacity that will be consumed during the next day. This is different from how the calculations were done before. At that time, although the tariffs were differentiated by periods of the day, they practically did not change from day to day. Only in the moments of their viewing. Looking at the data on electricity tariffs, different levels are distinguished, such as when it is very high, high, medium, low or very low. Therefore, the linguistic variable

"electricity tariff" will be described by five similar fuzzy sets with average values of 1.2, 2.475, 3.75, 5.025 and 6.3 UAH/kW·h. Its finite set itself will be limited by the values of $0 \leq p \leq 7$ UAH/kW·h. Graphs of membership functions (Table 4.3) are shown in fig.4.3, c

Table 4.3 – Functions of belonging to sets of the variable "Tariff for electric energy"

Vague plural	Membership function type	Membership function
«Very low intensity» (VL)	Sigmoid	$MF_{VL}(x a = -5, c = 1, 2) = \frac{1}{1 - \exp[-(-5)(x-1,2)^2]}$
«Low intensity» (L)	Gauss	$MF_L(x \sigma = 0,5, \bar{x} = 2,475) = \exp\left[\frac{-(x-2,475)^2}{2 \cdot 0,5^2}\right]$
«Medium intensity» (ME)	Gauss	$MF_{ME}(x \sigma = 0,5, \bar{x} = 3,75) = \exp\left[\frac{-(x-3,75)^2}{2 \cdot 0,5^2}\right]$
«High intensity» (H)	Gauss	$MF_H(x \sigma = 0,5, \bar{x} = 5,025) = \exp\left[\frac{-(x-5,025)^2}{2 \cdot 0,5^2}\right]$
«Very high intensity» (VH)	Gauss	$MF_{VH}(x a = 5, c = 6,3) = \frac{1}{1 - \exp[-5(x-6,3)^2]}$

The width of the PWM can vary from 0 to 100%, i.e. from values that correspond, on the one hand, to the absence of voltage, and on the other, to the maximum possible voltage level, therefore, the finite set **D** for such an initial linguistic variable will be limited as follows: $0 \leq d \leq 100$ %. For more precise lighting control, the linguistic variable "PWM-controller sparsity" during fuzzification will be described by seven fuzzy sets: "very very low" (VVL), "very low" (VL), "low" (L), "medium" (ME), "high" (H), "very high" (VH), "very, very high" (VVH). Graphs of membership functions (Table 4.4) are shown in Fig. 4.3, d.

Table 4.4 – Functions of belonging to the sets of the variable "Duty cycle of the PWM controller"

Vague plural	Membership function type	Membership function
«Very very low» (VVL)	Sigmoid	$MF_{VL}(x a = -1, c = 5) = \frac{1}{1 - \exp[-(-1)(x-5)^2]}$
«Very low» (VL)	Gauss	$MF_L(x \sigma = 5, \hat{x} = 16) = \exp\left[\frac{-(x-16)^2}{2 \cdot 5^2}\right]$
«Low» (L)	Gauss	$MF_L(x \sigma = 5, \hat{x} = 32) = \exp\left[\frac{-(x-32)^2}{2 \cdot 5^2}\right]$
«Medium» (ME)	Gauss	$MF_{ME}(x \sigma = 5, \hat{x} = 50) = \exp\left[\frac{-(x-50)^2}{2 \cdot 5^2}\right]$
«High» (H)	Gauss	$MF_H(x \sigma = 5, \hat{x} = 66) = \exp\left[\frac{-(x-66)^2}{2 \cdot 5^2}\right]$
«Very high» (VH)	Gauss	$MF_L(x \sigma = 5, \hat{x} = 82) = \exp\left[\frac{-(x-82)^2}{2 \cdot 5^2}\right]$
«Very, very high» (VVH)	Sigmoid	$MF_{VH}(x a = 1, c = 95) = \frac{1}{1 - \exp[-1(x-95)^2]}$

All functions from the table. 4.4 are smooth functions. The average values for them are 5, 16, 32, 50, 66, 82 and 95%, respectively.

The linguistic variable "power source" contains only two vague sets – "electric network" and "battery". In principle, for this system output is described by a clear logic – either to be powered by the battery or not. However, in order not to hybridize VLC, we also phase it. We limit the finite set S to the values of $0 \leq s \leq 1$. The parameters of the functions (Table 4.5) are selected in such a way (see Fig. 4.3 d) that smooth membership functions are as similar as possible to a clear logical representation. The value of 0.5 is a kind of threshold value in such a case. If VLC Mamdani sets a number at the output that is greater than or equal to 0.5, then the power is supplied from the city's power grid, if less – from the battery.

Table 4.5 – Functions of membership to sets of the variable "Power source"

Vague plural	Membership function type	Membership function
«Battery» (BAT)	Sigmoid	$MF_{BAT}(x a = -45, c = 0,5) =$ $= \frac{1}{1 - \exp[-(-45)(x - 0,5)^2]}$
«Electric grid» (GR)	Sigmoid	$MF_{VH}(x a = 0,5, c = 45) =$ $= \frac{1}{1 - \exp[-0,5(x - 45)^2]}$

4.2.2 The rule base

For the VLC mathematical model to function, it is necessary to form an expert knowledge base of fuzzy rules, which contains linguistic rule-dependencies in the form [128]:

$$(x_1 \sim a_{1j}, x_2 \sim a_{2j}, \dots, x_n \sim a_{nj}) \Rightarrow Y = d_j, j = 1, m, \quad (4.1),$$

where a_{ij} – the fuzzy set that evaluates the variable x_i in the j th rule;

θ_j – a logical operation connecting fragments of the j th rule;

m – the number of rules in the database.

Let's consider the principles of creating the FCSEL rule base.

The main qualitative characteristic of the EL system is the level of illumination of a certain part of the street, road surface, etc. That is, the main linguistic variable by which the base of rules will be filled will be "illumination". The increasing priority of the rules will occur as the amount of illumination decreases, i.e. from the fuzzy set "gloomy day" to the fuzzy set "full moon". Moreover, the rules for the set "full moon" will be the most important, since EL fulfills its purpose of working with it. For the set "gloomy day" the correspondence to the fuzzy set "very very low" of the linguistic variable "PWM controller speed" is determined without taking into account the intensity of traffic and the electricity tariff. This block of rules is shown below.

- IF** $u_1 = i_{VOD}$ **AND** $(u_2 = t_{VL} \text{ OR } u_2 = t_L \text{ OR } u_2 = t_{MD} \text{ OR } u_2 = t_H \text{ OR } u_2 = t_{VH}) \dots$
 $\text{AND } u_3 = p_{VL}$ **THEN** $y_1 = d_{VVL}$ **AND** $y_2 = s_{GR}$
- IF** $u_1 = i_{VOD}$ **AND** $(u_2 = t_{VL} \text{ OR } u_2 = t_L \text{ OR } u_2 = t_{MD} \text{ OR } u_2 = t_H \text{ OR } u_2 = t_{VH}) \dots$
 $\text{AND } u_3 = p_L$ **THEN** $y_1 = d_{VVL}$ **AND** $y_2 = s_{BAT}$
- IF** $u_1 = i_{VOD}$ **AND** $(u_2 = t_{VL} \text{ OR } u_2 = t_L \text{ OR } u_2 = t_{MD} \text{ OR } u_2 = t_H \text{ OR } u_2 = t_{VH}) \dots$
 $\text{AND } u_3 = p_{MD}$ **THEN** $y_1 = d_{VVL}$ **AND** $y_2 = s_{BAT}$
- IF** $u_1 = i_{VOD}$ **AND** $(u_2 = t_{VL} \text{ OR } u_2 = t_L \text{ OR } u_2 = t_{MD} \text{ OR } u_2 = t_H \text{ OR } u_2 = t_{VH}) \dots$
 $\text{AND } u_3 = p_H$ **THEN** $y_1 = d_{VVL}$ **AND** $y_2 = s_{BAT}$
- IF** $u_1 = i_{VOD}$ **AND** $(u_2 = t_{VL} \text{ OR } u_2 = t_L \text{ OR } u_2 = t_{MD} \text{ OR } u_2 = t_H \text{ OR } u_2 = t_{VH}) \dots$
 $\text{AND } u_3 = p_{VH}$ **THEN** $y_1 = d_{VVL}$ **AND** $y_2 = s_{BAT}$

For fuzzy sets "normalized illumination", "twilight", "full moon", the value of other inputs of the system is already taken into account. The value of the "PWM controller's bias" changes from "very low" at "normal illumination" to "very very high" at "full moon". Moreover, the higher the intensity of traffic, the higher the brightness of the lighting device is achieved. However, when the linguistic variable "electricity tariff" belongs to the fuzzy sets of "high" and "very high", then either the previous or the non-prior to the maximum applied fuzzy set of the variable "PWM-controller splicing" are applied at the current illuminance.

VLC on the choice of power source is based on the assessment of the electricity tariff, when it is average, high and very high, then a recommendation is given to connect the battery, when it is low and very low – to power from the city's power grid.

- IF $u_1 = i_{NR}$ AND $u_2 = t_{VL}$ AND ($u_3 = p_{VL}$ OR $u_3 = p_L$) THEN $y_1 = d_L$ AND $y_2 = s_{BAT}$
- IF $u_1 = i_{NR}$ AND $u_2 = t_{VL}$ AND $u_3 = p_{MD}$ THEN $y_1 = d_L$ AND $y_2 = s_{GR}$
- IF $u_1 = i_{NR}$ AND $u_2 = t_{VL}$ AND $u_3 = p_H$ THEN $y_1 = d_{VL}$ AND $y_2 = s_{GR}$
- IF $u_1 = i_{NR}$ AND $u_2 = t_{VL}$ AND $u_3 = p_{VH}$ THEN $y_1 = d_{VVL}$ AND $y_2 = s_{BAT}$
- IF $u_1 = i_{NR}$ AND $u_2 = t_L$ AND ($u_3 = p_{VL}$ OR $u_3 = p_L$) THEN $y_1 = d_{MD}$ AND $y_2 = s_{BAT}$
- IF $u_1 = i_{NR}$ AND $u_2 = t_L$ AND $u_3 = p_{MD}$ THEN $y_1 = d_{MD}$ AND $y_2 = s_{GR}$
- IF $u_1 = i_{NR}$ AND $u_2 = t_L$ AND $u_3 = p_H$ THEN $y_1 = d_L$ AND $y_2 = s_{GR}$
- IF $u_1 = i_{NR}$ AND $u_2 = t_L$ AND $u_3 = p_{VH}$ THEN $y_1 = d_{VL}$ AND $y_2 = s_{BAT}$
- IF $u_1 = i_{NR}$ AND $u_2 = t_{MD}$ AND ($u_3 = p_{VL}$ OR $u_3 = p_L$) THEN $y_1 = d_H$ AND $y_2 = s_{BAT}$
- IF $u_1 = i_{NR}$ AND $u_2 = t_{MD}$ AND $u_3 = p_{MD}$ THEN $y_1 = d_H$ AND $y_2 = s_{GR}$
- IF $u_1 = i_{NR}$ AND $u_2 = t_{MD}$ AND $u_3 = p_H$ THEN $y_1 = d_{MD}$ AND $y_2 = s_{GR}$
- IF $u_1 = i_{NR}$ AND $u_2 = t_{MD}$ AND $u_3 = p_{VH}$ THEN $y_1 = d_{MD}$ AND $y_2 = s_{BAT}$
- IF $u_1 = i_{NR}$ AND $u_2 = t_H$ AND ($u_3 = p_{VL}$ OR $u_3 = p_L$) THEN $y_1 = d_H$ AND $y_2 = s_{BAT}$
- IF $u_1 = i_{NR}$ AND $u_2 = t_H$ AND ($u_3 = p_{MD}$ OR $u_3 = p_H$) THEN $y_1 = d_{MD}$ AND $y_2 = s_{GR}$
- IF $u_1 = i_{NR}$ AND $u_2 = t_H$ AND $u_3 = p_{VH}$ THEN $y_1 = d_{MD}$ AND $y_2 = s_{BAT}$
- IF $u_1 = i_{NR}$ AND $u_2 = t_{VH}$ AND ($u_3 = p_{VL}$ OR $u_3 = p_L$) THEN $y_1 = d_H$ AND $y_2 = s_{BAT}$
- IF $u_1 = i_{NR}$ AND $u_2 = t_{VH}$ AND $u_3 = p_{MD}$ THEN $y_1 = d_H$ AND $y_2 = s_{GR}$
- IF $u_1 = i_{NR}$ AND $u_2 = t_{VH}$ AND $u_3 = p_H$ THEN $y_1 = d_{MD}$ AND $y_2 = s_{GR}$
- IF $u_1 = i_{NR}$ AND $u_2 = t_{VH}$ AND $u_3 = p_{VH}$ THEN $y_1 = d_{MD}$ AND $y_2 = s_{BAT}$

The VLC FCSEL is taken into account when deciding on the power source, but the battery connection is provided that there is a sufficient level of charge. That is, fuzzy logic is combined with classical logic. If the level of illumination and the intensity of movement are low, then the power of the lighting device is left low.

IF $u_1 = i_{TW}$ **AND** $u_2 = t_{VL}$ **AND** $(u_3 = p_{VL}$ **OR** $u_3 = p_L)$...
THEN $y_1 = d_{MD}$ **AND** $y_2 = s_{BAT}$
IF $u_1 = i_{TW}$ **AND** $u_2 = t_{VL}$ **AND** $u_3 = p_{MD}$ **THEN** $y_1 = d_L$ **AND** $y_2 = s_{GR}$
IF $u_1 = i_{TW}$ **AND** $u_2 = t_{VL}$ **AND** $u_3 = p_H$ **THEN** $y_1 = d_{VL}$ **AND** $y_2 = s_{GR}$
IF $u_1 = i_{TW}$ **AND** $u_2 = t_{VL}$ **AND** $u_3 = p_{VH}$ **THEN** $y_1 = d_{VL}$ **AND** $y_2 = s_{BAT}$
IF $u_1 = i_{TW}$ **AND** $(u_2 = t_L$ **OR** $u_2 = t_{MD})$ **AND** $(u_3 = p_{VL}$ **OR** $u_3 = p_L)$...
THEN $y_1 = d_H$ **AND** $y_2 = s_{BAT}$
IF $u_1 = i_{TW}$ **AND** $u_2 = t_L$ **AND** $u_3 = p_{MD}$ **THEN** $y_1 = d_{MD}$ **AND** $y_2 = s_{GR}$
IF $u_1 = i_{TW}$ **AND** $u_2 = t_L$ **AND** $u_3 = p_H$ **THEN** $y_1 = d_L$ **AND** $y_2 = s_{GR}$
IF $u_1 = i_{TW}$ **AND** $u_2 = t_L$ **AND** $u_3 = p_{VH}$ **THEN** $y_1 = d_L$ **AND** $y_2 = s_{BAT}$
IF $u_1 = i_{TW}$ **AND** $u_2 = (t_{MD}$ **OR** $u_2 = t_H)$ **AND** $u_3 = p_{MD}$ **THEN** $y_1 = d_H$ **AND** $y_2 = s_{GR}$
IF $u_1 = i_{TW}$ **AND** $u_2 = (t_{MD}$ **OR** $u_2 = t_H)$ **AND** $u_3 = p_H$ **THEN** $y_1 = d_{MD}$ **AND** $y_2 = s_{GR}$
IF $u_1 = i_{TW}$ **AND** $u_2 = t_{MD}$ **AND** $u_3 = p_{VH}$ **THEN** $y_1 = d_L$ **AND** $y_2 = s_{BAT}$
IF $u_1 = i_{TW}$ **AND** $(u_2 = t_H$ **OR** $u_2 = t_{VH})$ **AND** $(u_3 = p_{VL}$ **OR** $u_3 = p_L)$...
THEN $y_1 = d_{VH}$ **AND** $y_2 = s_{BAT}$

Always at high illumination of the road surface, which corresponds to a very cloudy day, i.e. from 50 lk and more, the brightness of the PWM is very, very low. The tariff for electricity and the intensity of traffic are not taken into account here, because according to the norms [130] the illumination should be 20 lk or below. Also, taking into account the low level of energy consumption of the lighting device in this case, power can be supplied from the battery and only when the cost of electricity is very low can you switch to the network.

With a low level of illumination "full moon" and traffic above average, if it is possible to power the lighting device from a battery, then it needs work, since in this case the energy consumption will be the highest and therefore it is not advisable to be powered from the power grid due to the high costs of purchasing electricity.

From the mains power supply occurs when the average cost of electricity. If the cost of electricity or electricity consumption is high, then it is advisable to put batteries into operation.

IF $u_1 = i_{FM}$ **AND** $(u_2 = t_{VL}$ **OR** $u_2 = t_L)$ **AND** $u_3 = p_{VL}$ **THEN** $y_1 = d_{MD}$ **AND** $y_2 = s_{BAT}$
IF $u_1 = i_{FM}$ **AND** $u_2 = t_{VL}$ **AND** $(u_3 = p_L$ **OR** $u_3 = p_{MD})$...
THEN $y_1 = d_L$ **AND** $y_2 = s_{GR}$
IF $u_1 = i_{FM}$ **AND** $u_2 = t_{VL}$ **AND** $(u_3 = p_H$ **OR** $u_3 = p_{VH})$...
THEN $y_1 = d_L$ **AND** $y_2 = s_{BAT}$
IF $u_1 = i_{FM}$ **AND** $u_2 = t_L$ **AND** $u_3 = p_L$ **THEN** $y_1 = d_{MD}$ **AND** $y_2 = s_{GR}$
IF $u_1 = i_{FM}$ **AND** $u_2 = t_L$ **AND** $(u_3 = p_{MD}$ **OR** $u_3 = p_H)$...
THEN $y_1 = d_{MD}$ **AND** $y_2 = s_{BAT}$
IF $u_1 = i_{FM}$ **AND** $u_2 = t_L$ **AND** $u_3 = p_{VH}$ **THEN** $y_1 = d_L$ **AND** $y_2 = s_{BAT}$
IF $u_1 = i_{FM}$ **AND** $u_2 = t_{MD}$ **AND** $u_3 = p_{VL}$ **THEN** $y_1 = d_{VH}$ **AND** $y_2 = s_{BAT}$
IF $u_1 = i_{FM}$ **AND** $u_2 = t_{MD}$ **AND** $u_3 = p_L$ **THEN** $y_1 = d_{VH}$ **AND** $y_2 = s_{BAT}$
IF $u_1 = i_{FM}$ **AND** $u_2 = t_{MD}$ **AND** $(u_3 = p_{MD}$ **OR** $u_3 = p_H)$...
THEN $y_1 = d_H$ **AND** $y_2 = s_{BAT}$
IF $u_1 = i_{FM}$ **AND** $u_2 = t_{MD}$ **AND** $u_3 = p_{VH}$ **THEN** $y_1 = d_{MD}$ **AND** $y_2 = s_{BAT}$
IF $u_1 = i_{FM}$ **AND** $(u_2 = t_H$ **OR** $u_2 = t_{VH})$ **AND** $(u_3 = p_{VL}$ **OR** $u_3 = p_L)$...
THEN $y_1 = d_{VH}$ **AND** $y_2 = s_{BAT}$
IF $u_1 = i_{FM}$ **AND** $u_2 = t_H$ **AND** $(u_3 = p_{MD}$ **OR** $u_3 = p_H)$...
THEN $y_1 = d_{VH}$ **AND** $y_2 = s_{BAT}$
IF $u_1 = i_{FM}$ **AND** $u_2 = t_H$ **AND** $u_3 = p_{VH}$ **THEN** $y_1 = d_H$ **AND** $y_2 = s_{BAT}$
IF $u_1 = i_{FM}$ **AND** $u_2 = t_{VH}$ **AND** $u_3 = p_{MD}$ **THEN** $y_1 = d_{VH}$ **AND** $y_2 = s_{BAT}$
IF $u_1 = i_{FM}$ **AND** $u_2 = t_{VH}$ **AND** $(u_3 = p_H$ **OR** $u_3 = p_{VH})$...
THEN $y_1 = d_{VH}$ **AND** $y_2 = s_{BAT}$

The output surfaces for VLC Mamdani are shown in fig. 4.4.

To evaluate the energy efficiency of EL fuzzy control, it is necessary to simulate the operation of the created system. We will generate test signals that will correspond to the actual operating conditions.

The input test signal by illumination consists of three parts. The first and third parts correspond to the natural twilight that occurs during sunset or sunrise. These two plots have exponential forms.

At night, the illumination is equal to 20 lk, which corresponds to the normalized value of artificial EL for road surfaces. The change in surface illumination, for example from car headlights, is simulated by adding a random variable as described below.

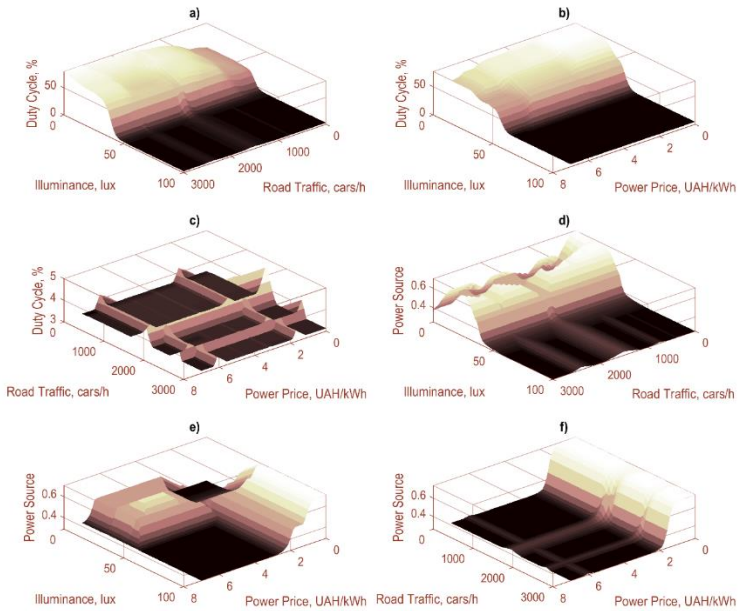

Figure 4.4 – Mamdani VLC system output surfaces

4.2.3 Conditions for modeling the outdoor lighting control system

To generate the main form of the signal in the summer and winter seasons, sunrise and sunset data for the periods 14.01.2024 – 15.01.2024 and 14.07.2024 – 15.07.2024 were taken. On January 15, 2024, twilight begins at 4:55 p.m. and lasts until nightfall at 5:34 p.m., i.e. 39 minutes. The night itself lasts until 06.19, i.e. 765 minutes. Then dawn begins, lasting 38 minutes until full sunrise at 06:57. On January 15, 2024, twilight begins at 9:21 p.m. and lasts until nightfall at 10:14 p.m., i.e. 52 minutes. The night itself lasts until 03:32, i.e. 318 minutes. Then dawn begins, lasting 53 minutes until full sunrise at 04.25. A random variable with a standard deviation of 20 lk is added to the main signal, which changes its value at each system discrete reading. The minimum value of the total signal is limited to 0 llk, since the illumination cannot be negative. Examples of input signals for winter time are shown in fig. 4.5, a (discrete step 5 min) and fig. 4.6, a (discrete step of 10 min), for summer – in fig. 4.7, a (discrete step 5 min) and fig. 4.8, a (discrete step 10 min).

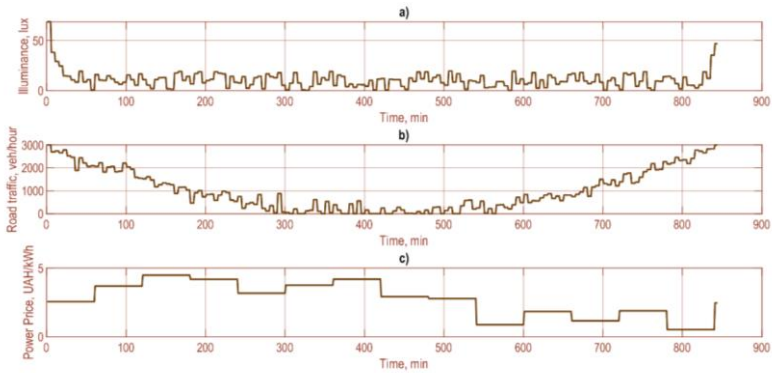

Figure 4.5 – Test signals for simulation of FCSEL operation on a winter night (discrete step 5 min)

As shown by studies [27, 131–134], in the night period of the day, road traffic is a convex function. At approximately 19–20 hours, the number of motor vehicles on the roads begins to decrease and reaches a minimum somewhere in the middle of the night, and then increases until 6–8 hours. This is due to the need to get home from work in the evening and in the morning and vice versa, as well as the absence of work trips at night. Such dependence is observed for roads in different cities and countries. At the same time, the traffic intensity graphs do not show a seasonal nature. And this is expected, since traffic is directly correlated with working hours [132], and they are always constant regardless of winter or summer. The traffic intensity will have a greater impact on the system performance in those seasons when the length of the night is longer, because in this case it will cover both high and low traffic periods. At other times, especially in the summer, the lighting will work more during times of low traffic. To model the input signal by auto traffic, we use a parabolic dependence [134] to which we add random variables. Examples of input signals for winter time are shown in fig. 4.5, b (discrete step of 5 min) and fig. 4.6, b (discrete step of 10 min), for summer – in fig. 4.7, b (discrete step 5 min) and fig. 4.8, b (discrete step 10 min).

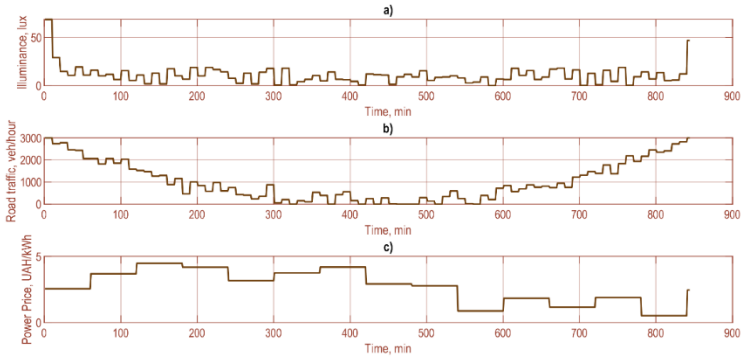

Figure 4.6 – Test signals for simulating FCSEL operation on a winter night (discrete step 10 min)

We generate the input test signal based on the electricity tariff based on market data, to which we add a random variable distributed according to the normal law with a standard deviation of 0.5 UAH/kWh. To analyze the operation of EL in the winter period, data on tariffs were taken from 17:00 14.02.2024 to 08:00 15.02.2024, in the summer period – from 21:00 17.04.2024 to 08:00 18.04.2024. In the last version, the information for April 2024 is taken, since taking 2023 is no longer very relevant, and the real tariffs for the date 07/15/2024 are not yet known at the time of the research. Examples of input signals for winter time are shown in fig. 4.5, c (discrete step of 5 min) and fig. 4.6, c (discrete step of 10 min), for summer – in fig. 4.7, c (discrete step of 5 min) and fig. 4.8, c (discrete step 10 min).

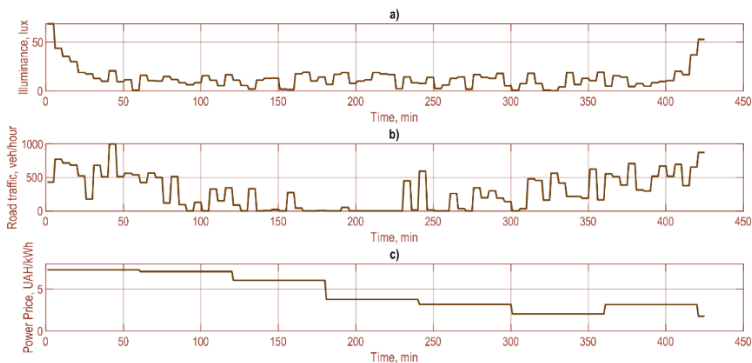

Figure 4.7 – Test signals for simulating FCSEL operation on a summer night (discrete step 5 min)

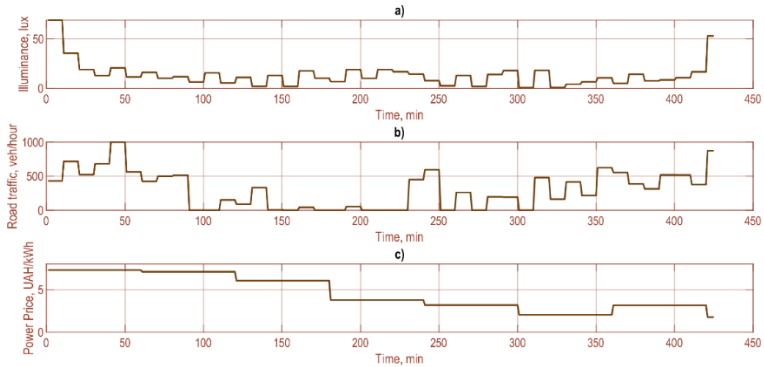

Figure 4.8 – Test signals for simulating the operation of the FCSEL on a summer night (discrete step 10 min)

4.2.4 Modeling of the outdoor lighting control system

In the winter time, electricity consumption in the system without control is calculated according to the schedule of work of EL in the city of Kryvyi Rih. That is, taking into account the fact that from the moment of sunset until 23.00 and after 05.00 and until full dawn, the lighting works at full capacity, and between 23.00 and 05.00 lighting installations either consume 50% of the total power, or the lighting network does not work. For summer time, it is accepted that, taking into account the fact that the initial stage of twilight begins already at 02.19 (data for 15.07.2024) and fully dawns already at 04.25, the EL shutdown time is 3 hours: from 23.00 to 02.00, since by 05.00 the need for EL is gone. We analyze two cases of lighting operation without control at night: lighting installations consume 50% of the total power; the lighting network does not work.

The calculation of power consumption when engaging the FCSEL was carried out for several options for setting a discrete step (5 and 10 minutes) between the measurements of illuminance and intensity of traffic and power sources of lighting installations (only from the mains and from the mains or battery). It is assumed that the battery has sufficient charge to power the lighting installation for the time that the FCSEL recommends drawing power from it. In the real case, of course, this is not the case, but it is enough to evaluate energy efficiency.

Let's analyze the results of modeling FCSEL operation for summer and winter night and ten LED lamps, shown in the table. 4.6. The operation

schedules of the Mamdani VLC system in winter and summer are shown in fig. 4.9 – 4.12.

Table 4.6 – FCSEL simulation results

Step, min	System configuration	Electricity consumption, W·h	
		In winter	In summer
-	No control / 50% power	11033.3	5533.33
-	Unmanaged / Disabled	8033.33	4033.33
10	Fuzzy mains powered control system	7959.55	2613.57
5	Fuzzy mains powered control system	7936.19	2571.66
10	Fuzzy mains/battery powered control system	2162.34	1365.95
5	Fuzzy mains/battery powered control system	2462.89	1387.04

As expected, the power supply of lighting installations from two power sources reduces the consumption of electrical energy more significantly. So, on a winter night when powered only from the power grid, consumption is reduced by 0.92% and 1.21%, for discrete steps of 10 and 5 minutes, if compared with a system without control when the lighting network is turned off for 6 hours, if at night for 6 hours only 50 % of power by lighting installations, then these percentages are equal to 27.85% and 28.07%. When looking at mains or battery power, there is a reduction of 73.08% and 69.34% and 80.4% and 77.68%, respectively. The situation is the same for a summer night. Powering the controlled system only from the mains provides a reduction in consumption by 35.2% and 36.24%, if compared with a system without control and disconnection of the lighting network for 3 hours, if compared with 50% power consumption, then by 52.77% and 53.52%. When looking at mains or battery power, there is a reduction of 66.13% and 65.61% and 75.31% and 74.93%, respectively.

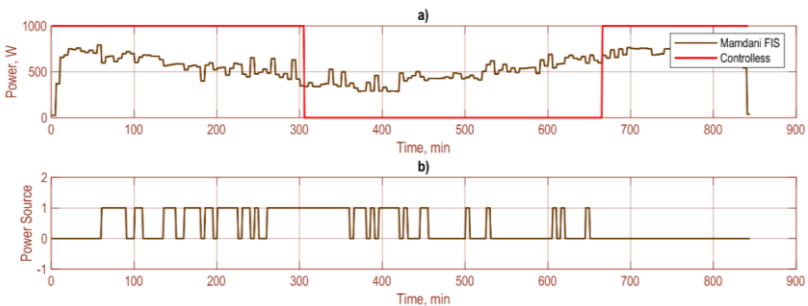

Figure 4.9 – Simulation of an FCSEL with 10 LEDs on a winter night (step 5 min)

Please note that the reduction in electricity consumption in the winter night, in the system with fuzzy control and power supply only from the power grid, is not very large, if compared with the system without control and complete EL shutdown, i.e. only 0.92% or 1.21% depending from a discrete step. This is due to the longer time of zero energy consumption by lighting devices in winter than in summer. However, the savings are small, but they are there, and therefore the system itself can be used.

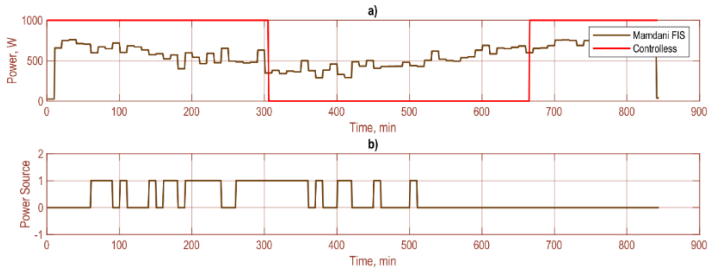

Figure 4.10 – Simulation of an FCSEL with 10 LED lights on a winter night (step 10 min)

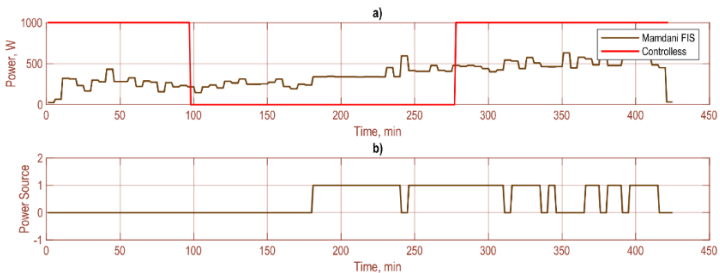

Figure 4.11 – FCSEL simulation with 10 LEDs on a summer night (step 5 min)

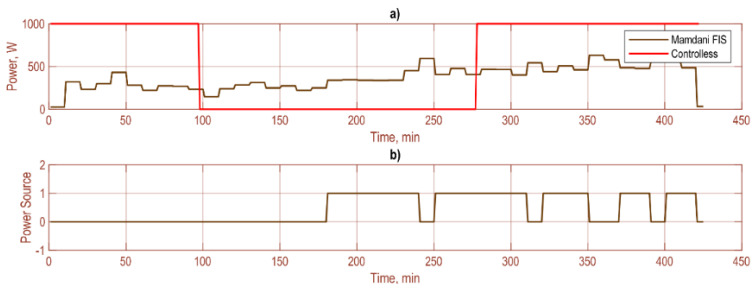

Figure 4.12 – FCSEL simulation with 10 LEDs on a summer night (step 10 min)

The discrete step has practically no effect, in most of the simulated FCSEL operation options, on the power consumption. So, for example, when powered only from the power grid, the difference is only 0.29% for lighting on a winter night and 1.04% on a summer night. When powered from a battery or mains for a summer night, the difference for different discrete steps was only 0.52%. Only when battery or mains power for a winter night was considered was the difference between the 5- and 10-minute discrete step settings more significant at 3.72%. These are the data if we compare the considered systems with a system without control and zero consumption by the lighting network during 6 hours of the night. For an unmanaged system with 50% consumption at night, the percentages do not vary much. This situation arises because the illumination and intensity of traffic does not change drastically during such steps.

It can be concluded that FCSEL is energy efficient. It is also recommended that specialized enterprises of settlements, in whose area of responsibility there is a lighting network, pay more attention not only to the replacement of light sources with new, more energy-efficient ones, but also to the introduction of alternative power sources of lighting installations that allow charging batteries during daylight hours, such as, for example, solar panels. This, together with the involvement of the considered FCSEL, will provide an opportunity to save even more on electricity costs, which is very relevant in modern conditions.

Conclusions to section 4

1. The improved fuzzy control system of the electrotechnical complex of outdoor lighting of cities and settlements, in addition to the level of illumination (as the main value) and the intensity of traffic, also takes into account the tariff for electric energy when generating the value of the control action by voltage or current (depending on the type of LED driver). The system also provides a recommendation for choosing a power source for the lighting installation, if a battery connection is also possible.

2. The modeling of the system of fuzzy control of the electrotechnical complex of outdoor lighting, which was carried out on the example of a part of the road illuminated by ten 100 W LED lamps for summer and winter night with different discrete steps of control, confirms the possibility of achieving the efficiency of outdoor lighting when using the proposed control option.

3. A controlled system with combined power is more effective. It allows you to reduce electricity consumption in the summer night by 75.31% and 74.93%, in the winter – by 80.4% and 77.68%, if compared with the usual version of outdoor lighting, when the lighting network is either completely turned off at night, or works only at 50% power, respectively. When powered

only from the power grid, consumption decreases in summer night by 28.07% and 1.21%, in winter – by 53.52% and 36.24%.

4. The discrete step has almost no effect on the energy efficiency of the fuzzy outdoor lighting control system. When powered only from the mains, the difference is 0.29% for lighting on a winter night and 1.04% on a summer night between two discrete steps of 5 and 10 minutes. When powered from an energy storage (battery) or power grid for a summer night, the difference for different discrete steps was only 0.52%.

CONCLUSIONS

The monograph examines the option of solving the scientific task of theoretical justification and development of methods for searching, evaluating and developing modern energy-oriented ways of increasing technological and electric power efficiency, reliability and continuity of outdoor lighting networks of cities and settlements both in regular and extreme modes of their operation. As a result of the work, the following generalizing scientific conclusions were obtained:

1. The existing structures and modes of operation of electric networks of outdoor lighting of cities and settlements of Ukraine in the modern vision of the necessary levels of achievement of functioning are examples of electric power systems with insufficient energy efficiency and a low level of reliability both in trivial modes of their operation, so that it is especially relevant – in those operating on time in the state conditions.

2. Formalized, based on the results of the analysis and evaluation of options for the structures of potentially effective outdoor lighting complexes, research directions and approaches to the formatting of algorithms for their effective management, make it possible to determine the main ways of developing options for energy-directed, technologically sufficient and achievable effective lighting systems with the maintenance of an appropriate level of mega-comfort for city dwellers and settlements.

3. Grounded and improved, in comparison with perfect and existing samples of outdoor lighting control systems, a new vision in solving the problem, which is analyzed by developing a concept based on the theory of building synergistic electric power systems, which allows obtaining a new significant positive result in the field of energy efficiency, reliability and uninterrupted power supply of electric networks of outdoor lighting of cities and settlements both in the variability of regular and non-regular modes of their operation.

4. Factors affecting the efficiency of the operation of electrotechnical complexes of outdoor lighting are analytically determined, the main ones of which are recognized as the level of illumination as a function of the activity of pedestrians and transport, which contributes to the development of the format of input and output parameters for the creation of an energy-efficient intelligent control system of outdoor lighting with the adoption of adaptive management decisions.

5. A variant with a distributed generation source is theoretically

justified and proposed for integration into the power supply system of the outdoor lighting complexes of populated areas, which will make it possible to increase the reliability and efficiency of the electrical systems being analyzed as a whole.

6. The proposed and tested model for controlling the luminous flux of outdoor lighting, which provides for monitoring and controlling the level of illumination of controlled areas with the subsequent adaptability of determining and transmitting control commands, contributes to the intellectualization of the control system of the outdoor lighting complex and at the same time will create conditions for the integration of the Micro Smart and Grid Smart City systems into the process functioning of the corresponding automated control system.

7. The proposed, substantiated and recommended for implementation aggregate approach to the construction of intelligent electrotechnical complexes for outdoor lighting of populated areas, which can and will ensure the operation of lighting networks, based on the use of fuzzy logic in controlling the operation of lighting devices, will allow adaptive control of the process of regulating the level of emitted lighting and electricity consumption. This will ensure safe traffic conditions, as well as the safety of pedestrians, which will significantly improve the architectural, touristic and commercial attractiveness of Ukrainian cities.

8. The known options have been improved and a new format of the fuzzy control system for the electrical complex of outdoor lighting of cities and settlements has been improved and recommended for practical implementation, which, based on information about illumination, the intensity of motor vehicle traffic and the tariff for electric energy, determines the recommended control signals by means of fuzzy logical inference based on the latitudinal pulse modulation for the driver of the lighting device and the power source of the lighting installation.

9. Modeling of the fuzzy outdoor lighting control system made it possible to determine that a power system with distributed generation of electrical energy is more and sufficiently energy efficient compared to others. It allows you to reduce electricity consumption in the summer night by 75.31% and 74.93%, in the winter – by 80.4% and 77.68%, if compared with the existing algorithms for regulating outdoor lighting, when the lighting network is turned off at night or completely, or works only at 50% capacity, respectively. With power supply only from the centralized power grid, consumption decreases in the summer night by 28.07% and 1.21%, in the winter – by 53.52% and 36.24%. It was also noted that the discrete step during control does not affect the energy efficiency of the electrical complex. When

powered only from the centralized power grid, the difference between five and ten minute steps is 0.29% for lighting on a winter night and 1.04% on a summer night. When powered from an autonomous energy source – a battery, or the power grid for a summer night, the difference for different steps is 0.52%.

BIBLIOGRAPHY

1. *State Statistics Service of Ukraine*. [Electronic resource]. [Free access. 05/06/2023].
http://ukrstat.gov.ua/operativ2018/energy/pve/ach_pve_u.htm.
2. Amosha O. I. *Man and the environment: economic problems of ecological safety of production*. Kyiv: Naukova dumka, 2002. 296p.
3. Polishchuk O. Yu. *Increasing the efficiency of outdoor lighting systems of streets and highways in cities: autoref. thesis Ph.D. technical Sciences: 05.09.07 / Kharkiv. national city university host. named after O. M. Beketova*. Kharkiv, 2014. 24 p.
4. Gonchar O. L. *Development of the regulatory framework for outdoor lighting in cities of Ukraine. Urban planning and territorial planning*. 2003. No. 16. P. 45–52.
5. Saltykov V. A., Sokolov V. F., Fedun T. V. *Increasing the reliability of power supply systems of outdoor lighting installations. Communal management of cities: science and technology*. coll. 2000. Issue 21. P. 122–125.
6. Saltykov V. A., Sokolov V. F., Fedun T. V. *To the issue of energy saving in outdoor lighting installations. Communal management of cities: science and technology*. coll. 1998. Vol. 17. P. 91–92.
7. Gorshkov. V. V., Sinchuk O. M. *Analysis of the current state and prospects for the development of artificial outdoor lighting systems in Ukraine. Electromechanical and energy-saving systems*. 2022. Issue 1(57). P. 55–60.
8. Pylypchuk R. V., Shchyrenko V. V. *More light – less consumed electricity. Energy saving in lighting. Electronic information*. 2002. No. 3. 2003. No. 1.
9. Fedun. T. V. *To the construction of systems for diagnostics and control of outdoor lighting installations. Bulletin of Kharkiv Polytechnic University. Series: New solutions in modern technologies*. 1999. Vol. 75. p. 106–108.
10. Govorov P. P., Govorov V. P., Kindinova A. K. *Automation of control modes of power supply and city lighting systems. Bulletin of the Vinnytsia Polytechnic Institute*. 2021. No. 5. P. 58–63.
11. Govorov P. P., Perepecheny V. O., Govorov V. P. *Lighting electrical systems and networks: training. a manual for students of the specialty "Lighting engineering and light sources"*. Kharkiv: Kharkiv National Academy of Urban Economy, 2009. 227 p.
12. Gorshkov V. V. *Peculiarities of construction of control systems*

for electrotechnical street lighting systems. *Modern scientific research: achievements innovations and development prospects*: 12th International scientific and practical conference, Berlin, Germany, May 22-24, 2022. Berlin, Germany, 2022. P. 195.

13. Weinert J. LED lighting: principles of operation, advantages and areas of application. Philips Solid-State Lighting Solutions, 2010. 156 p.

14. Sinchuk O. M., Horshkov V. V. Current state of development of artificial outdoor lighting systems in Ukraine. *Development of industry and society*: materials of the International Scientific and Technical Conference, Kryvyi Rih, October 03–07, 2022. Kryvyi Rih, 2022. P. 43.

15. Golovko V. M., Denisyuk P. L., Kyrlyenko V. M. Analysis of the principles of building local energy supply systems based on renewable energy sources. *Renewable energy of the 21st century*: IX International. conference, September 15–19, 2008. Crimea, 2008. P. 124–125.

16. Sinchuk O. M., Boyko S. M. Neural networks and control of the power supply management process of objects from combined electric networks. *Technical electrodynamics*. 2014. No. 5. P. 53–55.

17. Bilodid V. D., Taranets K. V. Small-scale energy and its importance in regional systems of the future. *Problems of general energy*. 2008. No. 18. p. 40–47.

18. Kudrya S.O., Morozov Yu.P., Kuznetsov M.P. Research on the effectiveness of the combined use of wind energy, sun and earth's heat to obtain hydrogen during water electrolysis. *Hydrogen in alternative energy and the latest technologies*: theses add. scientific reporting session of the National Academy of Sciences of Ukraine. Kyiv, 2013. P. 30

19. Zhurahivskiyi A. V., Zasadkovich N. R., Yatseiko A. Ya. Optimization of modes of electric power systems: training. study guide electricity special Lviv: Publishing House of the National University "Lviv Polytechnic", 2009. 140 p.

20. Zharkin A.F., Denisyuk S.P., Popov V.A. Electric power supply systems with sources of distributed generation: monograph. Kyiv: Naukova dumka, 2017. 230 p.

21. Increasing the quality indicators of correlation systems / G. F. Zaitsev, V. L. Bulgach, N. V. Gradoboeva, A. V. Saiko. *Modern trends in the development of technologies in communications and education*: materials of VIII sciences. conference, Kyiv, November 24–25, 2011. Kyiv: DUKT, 2011. P. 226–231.

22. "Smart" lighting of cities. URL: <https://5watt.ua/uk/blog/statti/rozumne-osvitlennya-mist> (date of application: 27.11.2022).

23. Alattar, E. M., Elwasife, K. Y., & Radwan, E. S. The Effect of Light-Emitting Diode Light on the Physical Traits of Chicks. *Journal of Animal Sciences*. 2019. 9. PP.481-491.
24. Alvino, G. M., Archer, G. S., & Mench, J. A. Behavioural time budgets of broiler chickens reared in varying light intensities. *Applied Animal Behaviour Science*. 2009. 118(1-2). PP. 54-61.
25. Sinchuk I. O., Boyko S. M. Lighting installations and systems: a course of lectures. Kremenchuk, 2015. 199 p.
26. Sinchuk O., Gorshkov V. Control of the electrotechnical complex of street lighting using a fuzzy controller. *Technical sciences and technologies*. 2022. № 2(28). C. 138–145. DOI: [https://doi.org/10.25140/2411-5363-2022-2\(28\)-138-145](https://doi.org/10.25140/2411-5363-2022-2(28)-138-145).
27. Popa V., Lavric A. A Traffic Prediction Algorithm for Street Lighting Control Efficiency. *Journal of Applied Computer Science & Mathematics*. 2013. Vol. 7, no. 15. PP. 13–17.
28. Carli R., Dotoli M., Pellegrino R. A decision-making tool for energy efficiency optimization of street lighting. *Computers & Operations Research*. 2018. No. 96. PP. 223–235.
29. Collantes-Duarte J., Rivas-Echeverria F. Time series forecasting using ARIMA, Neural Networks and Neo Fuzzy Neurons. Proceedings of the WSEAS Multiconference: *Neural Network and Applications, Fuzzy Sets and Fuzzy Systems, Evolutionary Computations*, Interlaken, Switzerland, February 11–15, 2002. Interlaken, 2002. PP. 4641–4646. URL: <http://www.wseas.us/e-library/conferences/switzerland2002/papers/464.pdf> (date of application: 28.04.2016).
30. Archer, G. S. Comparison of incandescent, CFL, LED and bird level LED lighting: Growth, fear and stress. *International Journal of Poultry Science*. 2015. 14(8). P. 449.
31. Archer, G. S. Comparison of raising broiler chickens under light emitting diode or incandescent light at differing intensities on growth, stress and fear. *International Journal of Poultry Science*. 2016. 11. PP. 425-431.
32. Arowolo, M. A., He, J. H., He, S. P., Adebowale, T. O. The implication of lighting programmes in intensive broiler production system. *World's Poultry Science Journal*. 2019. 75(1). PP. 17-28.
33. Gorshkov V. V. Energy-efficient electrotechnical complex with elements of intelligent control of the street lighting process in populated areas: monograph. Warsaw: iScience, 2023. 94 p.
34. On the improvement of settlements: Law of Ukraine dated September 6, 2005 No. 2807-IV. *Information of the Verkhovna Rada of Ukraine*. 2005. No.49. Article 517.

35. Light-adjusting sensor for registration and analysis of illumination (Gira 057200). URL: <https://knx24.com/catalog/goods/22432/> (date of application: 27.11.2022).
36. DBN V.2.5-28-2006. Engineering equipment of buildings and structures. Natural and artificial lighting. Valid since 2006-10-01. Kind. officer Kyiv: Ministry of Construction of Ukraine, 2016. 78 p.
37. Kharchenko V.F., Yakunin O.A., Voropai V.G. Power supply of cities and industrial enterprises: a summary of lectures (for students of all forms of education in the field of knowledge 14 – Electrical engineering, specialties 141 – Power engineering, electrical engineering and electromechanics, professional direction « Electrical systems of power consumption»). Kharkiv: XNUMX named after O. M. Beketova, 2019. 238 p.
38. Nazarenko V.M., Nazarenko M.V., Smirnova N.V., Kupin A.I. Ways of preserving and developing the potential of domestic IT technologies / *Bulletin of KTU, Kryvyi Rih*. 2005. No. 9. P. 95–100.
39. Strategy for the development of artificial intelligence in Ukraine: a monograph / edited by A. I. Shevchenko. Kyiv, 2023. 305 p.
40. Shchokin V.P. Intelligent control systems: analytical synthesis and research methods. Kryvyi Rih, 2010. 264 p.
41. Blatchford, R. A., K. C. Klasing, H. L. Shivaprasad, P. S. Wakenell, G. S. Archerand, J. A. Mench. The effect of light intensity on the behavior, eye and leg health, and immune function of broiler chickens. *Poultry Science*. 2009. 88. PP. 20–28.
42. Baxter, M., Joseph, N., Osborne, V. R., & Bedecarrats, G. Y. Red light is necessary to activate the reproductive axis in chickens independently of the retina of the eye. *Poultry Science*. 2014. 93(5), PP. 1289-1297.
43. Road Lighting Installation Design to Optimize Energy Use by Genetic Algorithms / A. Covitti, G. Delvecchio, F. Neri, A. Ripoli, M. S. Labini. *EUROCON 2005 – The International Conference on «Computer as a Tool»*, Belgrade, Serbia, 2005. PP. 1541–1544. DOI: 10.1109/EURCON.2005.1630259.
44. An Intelligent System for Street Lighting Control and Measurement / G. W. Denardin, C. H. Barriquello, R. A. Pinto, M. F. Silva, A. Campos, R. N. do Prado. *2009 IEEE Industry Applications Society Annual Meeting*, Houston, TX, USA, 2009. PP. 1–5. DOI: 10.1109/IAS.2009.5324800.
45. Mahoor M., Salmasi F. R., Najafabadi T. A. A Hierarchical Smart Street Lighting System With Brute-Force Energy Optimization. *IEEE Sensors Journal*. 2017. Vol. 17. PP. 2871–2879. DOI:

10.1109/JSEN.2017.2684240.

46. Popa M., Cepisca C. Energy consumption saving solutions based on intelligent street lighting control system. *UPB Scientific Bulletin, Series C: Electrical Engineering*. 2011. Vol. 73, Iss. 4. PP. 297–308.

47. Street lighting in smart cities: A simulation tool for the design of systems based on narrowband PLC / A. Sittoni, D. Brunelli, D. Macii, P. Tosato, D. Petri. *2015 IEEE First International Smart Cities Conference (ISC2)*, Guadalajara, Mexico, 2015. PP. 1–6. DOI: 10.1109/ISC2.2015.7366195.

48. Advanced Street Lighting Control through Neural Network Ensembling / F. Moretti, S. Pizzuti, M. Annunziato, S. Panziera. *SMART 2013 – The Second International Conference on Smart Systems, Devices and Technologies*, Rome, Italy, June 23–28, 2013. PP. 76–81.

49. Wojnicki I., Kotulski L. Street lighting control, energy consumption optimization. *Artificial Intelligence and Soft Computing: 16th International Conference ICAISC 2017*, Zakopane, Poland, June 11–15, 2017. PP. 123–127. DOI: 10.15439/2017F389.

50. Miki M., Hiroyasu T., Imazato K. Proposal for an intelligent lighting system, and verification of control method effectiveness. *IEEE Conference on Cybernetics and Intelligent Systems*, Singapore, 2004. Vol. 1. PP. 520–525. DOI: 10.1109/ICCIS.2004.1460469.

51. Department for Environment Food and Rural Affairs (DeFRA) A Review of Local Authority Road Lighting Initiatives Aimed at Reducing Costs, Carbon Emissions and Light Pollution. Temple Group Ltd; London: 2011.

52. Beyer, F.R., Ker, K. Street lighting for preventing road traffic injuries. *Cochrane Database of Systematic Reviews Issue*, 2009. 1. Art. No.: CD004728. DOI: 10.1002/14651858.CD004728.pub2.

53. Claudio L. Switch on the night: policies for smarter lighting. *Environ. Health Perspect.* 2009;117:A28–A31.

54. Bluetooth Smart Based Attendance Management System / R. Lodha, S. Gupta, H. Jain, H. G. Narula. *Procedia Computer Science*. 2015. Vol. 45. PP. 524–527. DOI: 10.1016/J.PROCS.2015.03.094.

55. Derges J., Lynch R., Clow A., Pettecrew M., Draper A. Complaints about dog faeces as a symbolic representation of incivility in London, UK: a qualitative study. *Crit. Public Health*. 2012;22(4):419–425.

56. Wang Y., Dasgupta P. Designing an adaptive lighting control system for smart buildings and homes. *IEEE: 12th International Conference on Networking, Sensing and Control*, Taipei, Taiwan, 2015. PP. 450–455. DOI: 10.1109/ICNSC.2015.7116079.

57. Yoomak S., Ngaopitakkul A. Feasibility Analysis of Different Energy Storage Systems for Solar Road Lighting Systems. *IEEE Access*. 2019. Vol. 7. PP. 101992–102001. DOI: 10.1109/ACCESS.2019.2926105.
58. Nasser M., Hassan H. Assessment of standalone streetlighting energy storage systems based on hydrogen of hybrid PV/electrolyzer/fuel cell/ desalination and PV/batteries. *Journal of Energy Storage*. 2023. Vol. 63. DOI: <https://doi.org/10.1016/j.est.2023.106985>.
59. Design Optimization of Standalone PV-Battery System for LED Street Lighting in Magetan Indonesia / D. Warindi, M. Nizam, F. Adriyanto, M. Anwar, A. Ramelan, J. S. Saputro, I. Inayati. *E3S Web of Conf*. 2023. Vol. 465. DOI: <https://doi.org/10.1051/e3sconf/202346502051>.
60. Assessment of LiFePO₄ Battery Performance in Stand Alone Photovoltaic Street Light System / A. Jamaluddin, A. N. Aini, E. Adhitama, A. Purwanto. *Procedia Engineering*. 2017. Vol. 170. PP. 503–508. DOI: <https://doi.org/10.1016/j.proeng.2017.03.080>.
61. Saprika A. V. Increasing the energy efficiency of lighting complexes taking into account the quality of electrical energy: monograph. Kharkiv: KhNAMG, 2009. 126 p.
62. Falchi F., Cinzano P., Elvidge C.D., Keith D.M., Haim A. Limiting the impact of light pollution on human health, environment and stellar visibility. *J. Environ. Manag.* 2011;92(10):2714–2722.
63. Synopsis of lectures from the course "Theory of automatic control" (for full-time and part-time students of the 6.050701 "Electrical engineering and electrical technologies") / P. P. Govorov, V. P. Govorov, V. O. Perepecheny, O. V. Korol. Kharkiv: KhNAMG, 2012. 221 p.
64. Tarasenko M. G., Kozak K. M. Limitably possible light returns of light sources. *Lighting and electrical engineering*. 2016. No. 3. P. 8–13.
65. Govorov P. P., Korol O. V., Nosan N. I., Romanova T. I. Dynamic lighting system based on LED light. *Light Lux*. 2011. No. 6. P. 46–50.
66. Nazarov V. V. Concept of Smart Grid and real energy. *Energy and electrification: science and production*. journal 2013. No. 6 (356). P. 12–15.
67. Green J., Thorogood N. Sage; London: 2014. Qualitative Methods for Health Research.
68. Nazarenko L. A., Zubkov D. P., Reva S. A. Methods of measuring light intensity and luminous flux of LEDs. *Ukrainian Metrological Journal*. 2010. No. 3. P. 29–33.
69. Economy of electrical energy in power supply networks / compilers: O. I. Solovei, O. M. Sukhodolya, V. P. Rozen, A. V. Chernyavskiy. Kyiv: PP "Kazhan Plus", 2004. 60 p.
70. Review of analytical works of international energy organizations

regarding the state and scenarios of development of the world energy sphere with a forecast of investing in energy efficiency. Kyiv: NEC "Ukrenergo", 2018. 95 p.

71. Energy-efficient lighting systems for industrial and communal consumers: training manual / P. G. Pleshkov, A. Yu. Orlovych, S. V. Serebrennikov, etc.; ed. P. G. Pleshkov. Kropyvnytskyi: National Technical University, 2018. 246 p.

72. Monitoring and control of electricity consumption of utility consumers / P. Pleshkov et al. *Automation, computer-integrated technologies of economy (AKIT-2022)*: International scientific and technical conference, Kropyvnytskyi, November 10–11. 2022. P. 80–81.
URL: <https://dSPACE.kntu.kr.ua/handle/123456789/12436>.

73. Optimal control of the modes of distribution electric networks with solar power plants under asymmetric load / A. I. Sachenko, S. P. Pleshkov, P. G. Pleshkov, V. V. Zinzura // *Central Ukrainian Scientific Bulletin. Technical sciences*: coll. of science pr. – Kropyvnytskyi: National Technical University, 2022. Issue 6(37). Part 1. P. 37-44.
URL: [https://doi.org/10.32515/2664-262X.2022.6\(37\).1.37-44](https://doi.org/10.32515/2664-262X.2022.6(37).1.37-44).

74. Hölker F., Moss T., Griefahn B., Kloas W., Voigt C.C., Henckel D., Hänel A., Kappeler P.M., Völker S., Schwope A. The dark side of light: a transdisciplinary research agenda for light pollution policy. *Ecol. Soc.* 2010;15(4):13.

75. Jones A.J.H. Ashgate Publishing Limited; Farnham: 2014. On the South Bank: The Production of Public Space.

76. Trunova I. M., Volotka L. Yu., Nasedkina T. L. Improvement of the technique of energy audit of the lighting system. *Bulletin of the Petro Vasylenko Kharkiv National Technical University of Agriculture*. Vol. 130: Problems of energy supply and energy saving in the agricultural sector of Ukraine. Kharkiv: KhNTUSG, 2012. P. 33–35.

77. Martland S.J. Progress illuminating the world: street lighting in Santiago, Valparaiso and La Plata, 1840–90. *Urban Hist.* 2002;29(2):223–238.

78. McFadden E., Jones M.E., Schoemaker M.J., Ashworth A., Swerdlow A.J. The relationship between obesity and exposure to light at night: cross-sectional analyses of over 100,000 women in the breakthrough generations study. *Am. J. Epidemiol.* 2014;180:245–250.

79. Alhamwi A., Unaichi C., Medjroubi W. Modeling Urban Street Lighting Infrastructure Using Open Source Data Sets. *ETG Congress 2021*. 2021. P. 1–6. URL: <https://ieeexplore.ieee.org/document/9469640>.

80. Urban Street Lighting Infrastructure Monitoring Using a Mobile

Sensor Platform / S. Kumar et al. *IEEE Sensors Journal*. 2016. Vol. 16, no. 12. P. 4981–4994. URL: <https://doi.org/10.1109/JSEN.2016.2552249>.

81. Liu Y. Research on the Innovation of Urban Street Visualization Light Monitoring System based on GIS Technology. *4th International Conference on Machinery (MACMC)*. 2018. P. 19–22. URL: <https://doi.org/10.2991/macmc-17.2018.5>.

82. Smart City: Recent Advances in Intelligent Street Lighting Systems Based on IoT / A. Omar et al. *Journal of Sensors*. 2022. Vol. 4. P. 1–10. URL: <https://doi.org/10.1155/2022/5249187>.

83. Design and Implement IoT-Based Intelligent Manageable Smart Street Lighting Systems for Future Smart City / M.H. Kabir et al. *Engineering Proceedings*. 2023. Vol. 56, no. 1. URL: <https://doi.org/10.3390/ASEC2023-15535>.

84. Balazs L., Braun F., Lengyel J. Energy Saving Potential of Traffic-Regulated Street Lighting. *Sustainability*. 2023. Vol. 15, no. 8. 6750. URL: <https://doi.org/10.3390/su15086750>.

85. Smart Street Light Control: A Review on Methods, Innovations, and Extended Applications / F. Agramelal et al. *Energies*. 2023. Vol. 16, no. 21. 7415. URL: <https://doi.org/10.3390/en16217415>.

86. Yan P., Wang J. Intelligent Street Light Control System Based on Fuzzy Control Algorithm. *Academic Journal of Computing & Information Science*. 2022. Vol. 5, no. 4. P. 35–40. URL: <https://doi.org/10.25236/AJCIS.2022.050406>.

87. Wang J., Yan P. Intelligent Street Light Control System Based on Fuzzy Control Algorithm. *Academic Journal of Computing & Information Science*. 2022. Vol. 5, no. 7. P. 27–32. URL: <https://doi.org/10.25236/AJCIS.2022.050705>.

88. Satam I.A. Fuzzy-based smart system for controlling road lights. *Vojnotehnicki glasnik*. 2022. Vol. 70, no. 2. P. 297–313. URL: <https://doi.org/10.5937/vojtehg70-36670>.

89. Intelligent Street Lamp Control System with Dynamic Light Control Function / J. Zeng et al. *17th International Symposium on Distributed Computing and Applications for Business Engineering and Science (DCABES)*. 2018. P. 181–183. URL: <https://doi.org/10.1109/DCABES.2018.00054>.

90. Wu H., Li C., Duan G. Research on a fuzzy algorithm for intelligent power-saving control of urban street lamps. *Proceedings of the Institution of Civil Engineers – Smart Infrastructure and Construction*. 2024. Vol. 177, no. 1. P. 3–14. URL: <https://doi.org/10.1680/jsmic.23.00010>.

91. Ai M., Wang P., Ma W. Research and application of smart

streetlamp based on fuzzy control method. *Procedia Computer Science*. 2021. Vol. 183. P. 341–348.

URL: <https://doi.org/10.1016/j.procs.2021.02.069>.

92. Shadli A., Hanafi D. Development of a n Intelligence Street Light Using Fuzzy Logic in Control System. *Evolution in Electrical and Electronic Engineering*. 2020. Vol. 1, no. 1. P. 1–5.

URL: <https://doi.org/10.30880/eeee.2020.01.01.001>.

93. Rules for arranging electrical installations. The publication is official. Kyiv: Ministry of Energy and Coal, 2017. 617 p.

94. Saltykov V.O. City lighting: training manual. Kharkiv: KhNAMG, 2019, 221 p.

95. Outdoor lighting. *Official portal of Kyiv*: website. URL: https://kyivcity.gov.ua/navkolnyshnie_seredovyshche_mista/vulychne_osvitlennia/zovnishnie_osvitlennia (date of application: 10.04.2024).

96. In the Poltava community, the outdoor lighting schedule has been changed. *Society Poltava*: website. URL: <https://suspilne.media/poltava/540495-v-poltavskij-gromadi-zminili-grafik-zovnisnogo-osvitlennia> (date of application: 10.04.2024).

97. From October 1, the outdoor street lighting schedule will be changed in Kryvyi Rih. Rudana: website. URL:

<https://rudana.com.ua/news/z-1-zhovtnya-u-kryvomu-rozi-zminyati-grafik-zovnishnogo-osvitlennya-vulyc> (date of application: 10.04.2024).

98. Dovgiy S.O., Ivanchenko V.V., Korzhnev M.M., Trofymchuk O.M., Yakovlev E.O. etc. Study of the ecological state of the post-mining territories in Ukraine using the example of the Kryvyi Rih basin and its surroundings. Nika Center, 2021. 196 p.

99. Sinchuk O.M., Mykhaylenko O.Yu., Horshkov V.V. Fuzzy control system of the electrotechnical complex of street lighting in populated areas. *Central Ukrainian Scientific Bulletin*, No. 9(40), Part I, 2024, p. 205-217.

100. S. Nakamura, M.R. Krames History of gallium–nitride-based light-emitting diodes for illumination Proc. IEEE, 120 (2013), p. 2211

101. Statistical data processing: monograph / V. Babak et al. Kyiv: MIVVC, 2001. 388 p.

102. Petergerya Yu. S., Zhuykov V. Ya., Tereshchenko T. O. Intelligent systems for energy saving in residential buildings: training manual Kyiv: Media-PRESS, 2008. 255 p.

103. Shaw R. Streetlighting in England and Wales: new technologies and uncertainty in the assemblage of streetlighting infrastructure. *Environ. Plan. A*. 2014;46(9):2228–2242.

104. Shaw R. Controlling darkness: self, dark and the domestic night. *Cult. Geogr.* 2014.

105. Shuboni D., Yan L. Nighttime dim light exposure alters the responses of the circadian system. *Neuroscience.* 2010;170(4):1172–1178.

106. The Royal Commission of Environmental Light Pollution. The Stationary Office; London: 2009. *Artificial Light in the Environment.*

107. Vohra S. Trafford LED Street Lighting Programme Health Impact Assessment. IOM Centre for Health Impact Assessment; Edinburgh: 2013.

108. Design of Battery System for Solar Powered Street Light / M. Parameswari, A. Kowsika, M. Priyadharshini, S. Priyanka, M. Udhaya Priya. *International Journal of Advanced Trends in Engineering and Technology.* 2021. Vol. 6, Issue 1. PP. 13–16.

109. Mykhailenko O. Modeling and simulating dynamics of lithiumion batteries using block-oriented models with piecewise linear static nonlinearity. E3S Web Conf.: *Second International Conference on Sustainable Futures: Environmental, Technological, Social and Economic Matters.* 2021. Vol. 280. DOI: <https://doi.org/10.1051/e3sconf/202128005004>.

110. Bai H., Song Z. (2023). Lithium-ion battery, sodium-ion battery, or redox-flow battery: A comprehensive comparison in renewable energy systems. *Journal of Power Sources.* 2023. Vol. 580. DOI: 10.1016/j.jpowsour.2023.233426.

111. Comparison the Economic Analysis of the Battery between Lithium-ion and Lead-acid in PV Stand-alone Application / S. Anuphapharadorn, S. Sukchai, C. Sirisamphanwong, N. Ketjoy. *Energy Procedia.* 2014. Vol. 56. PP. 352–358. DOI: <https://doi.org/10.1016/J.EGYPRO.2014.07.167>.

112. Wang X., Adelman P., Reindl T. Use of LiFePO₄ Batteries in Stand-Alone Solar System. *Energy Procedia.* 2012. Vol. 25. PP. 135–140. DOI: 10.1016/j.egypro.2012.07.018.

113. Poullikkas A. A comparative overview of large-scale battery systems for electricity storage. *Renewable and Sustainable Energy Reviews.* 2013. Vol. 27(C). PP. 778–788. DOI: 10.1016/j.rser.2013.07.017.

114. Battery technologies: exploring different types of batteries for energy storage / E. Rakhimov, D. Khoshimov, S. Sulonov, F. Jamoldinov, A. Imyaminov, B. Omonov. *BIO Web of Conferences.* 2024. Vol. 84. DOI: 10.1051/bioconf/20248405034.

115. Special sections of energy. Unconventional and renewable energy: a textbook / O. M. Sinchuk et al. Kremenchuk, 2017. 217 p.

116. Elejoste, P., Angulo, I., Perallos, A., Chertudi, A., Zuazola, I. J. G., Moreno, A., Azpilicueta, L., Astrain, J. J., Falcone, F., & Villadangos, J. (2013). An Easy to Deploy Street Light Control System Based on Wireless Communication and LED Technology. *Sensors*, 13(5), Article 5. <https://doi.org/10.3390/s130506492>

117. Horshkov V.V. Assessment of the need to involve intelligent management in the automation of street lighting control of cities and settlements. *International Scientific and Technical Conference "Development of Industry and Society" (May 23-24, 2024)*. Kryvyi Rih National University. Kryvyi Rih, 2024. P. 86.

118. Ali, M., Orabi, M., Abdelkarim, E., Qahouq, J. A. A., & Aroudi, A. E. (2011). Design and development of energy-free solar street LED light system. 2011 IEEE PES Conference on Innovative Smart Grid Technologies – Middle East, 1–7. <https://doi.org/10.1109/ISGT-MidEast.2011.6220812>

119. Lagorse, J., Paire, D., & Miraoui, A. (2009). Sizing optimization of a stand-alone street lighting system powered by a hybrid system using fuel cell, PV and battery. *Renewable Energy*, 34(3), 683–691. <https://doi.org/10.1016/j.renene.2008.05.030>

120. Azzollini, I. A., Felice, V. D., Fraboni, F., Cavallucci, L., Breschi, M., Rosa, A. D., & Zini, G. (2018). Lead-Acid Battery Modeling Over Full State of Charge and Discharge Range. *IEEE Transactions on Power Systems*, 33(6), 6422–6429. <https://doi.org/10.1109/TPWRS.2018.2850049>

121. Cowern, N. E. B. (2012). 1—Silicon-based photovoltaic solar cells. In J. A. Kilner, S. J. Skinner, S. J. C. Irvine, & P. P. Edwards (Eds.), *Functional Materials for Sustainable Energy Applications* (pp. 3–22e). Woodhead Publishing. <https://doi.org/10.1533/9780857096371.1.1>

122. Smart Grid. (n.d.). Energy.Gov. Retrieved May 15, 2024, from <https://www.energy.gov/smart-grid>

123. Smart energy. (n.d.). IEC. Retrieved May 15, 2024, from <https://www.iec.ch/energies/smart-energy>

124. Smart Grids. (n.d.). Netl.Doe.Gov. Retrieved May 15, 2024, from <https://netl.doe.gov/smartgrids>

125. The Leaders in Smart Grid Technology—IEEE Smart Grid. (n.d.). Retrieved May 16, 2024, from <https://smartgrid.ieee.org/>

126. Battaglini, A., Lilliestam, J., Haas, A., & Patt, A. (2009). Development of SuperSmart Grids for a more efficient utilisation of electricity from renewable sources. *Journal of Cleaner Production*, 17(10), 911–918. <https://doi.org/10.1016/j.jclepro.2009.02.006>

127. Kaygusuz, A., Tuttokmağlı, Ö., Keleş, C., & Alagöz, B. B. (2018). Possible Contributions of Smart Grids to Regional Development of

Countries. 2018 International Conference on Artificial Intelligence and Data Processing (IDAP), 1–4. <https://doi.org/10.1109/IDAP.2018.8620772>

128. Zheldak T.A. Koryashkina L.S., Us S.A. Fuzzy sets in management and decision-making systems: education. manual / under the editorship S.A. Us. Dnipro: NTU "DP", 2020. 387 p.

129. Radiometry and photometry in astronomy. URL: <https://www.stjarnhimlen.se/comp/radfaq.html> (date of application: 10.04.2024).

130. DBN V.2.5-28:2018 Natural and artificial lighting. URL: <https://ips.ligazakon.net/document/DBN00078> (date of application: 10.04.2024).

131. He, H., Wang, J., Wei, H., Ye, C., & Ding, Y. (2016). Fractal behavior of traffic volume on urban expressway through adaptive fractal analysis. *Physica A: Statistical Mechanics and Its Applications*, 443, 518–525. <https://doi.org/10.1016/j.physa.2015.10.004>

132. Venkatanarayana, R., Smith, B. L., & Demetsky, M. J. (2007). Quantum-Frequency Algorithm for Automated Identification of Traffic Patterns. *Transportation Research Record*, 2024(1), 8–17. <https://doi.org/10.3141/2024-02>

133. Järv, O., Ahas, R., Saluveer, E., Derudder, B., & Witlox, F. (2012). Mobile Phones in a Traffic Flow: A Geographical Perspective to Evening Rush Hour Traffic Analysis Using Call Detail Records. *PLOS ONE*, 7(11), e49171. <https://doi.org/10.1371/journal.pone.0049171>

134. Zambrano-Martinez, J. L., Calafate, C. T., Soler, D., Cano, J.-C., & Manzoni, P. (2018). Modeling and Characterization of Traffic Flows in Urban Environments. *Sensors*, 18(7), Article 7. <https://doi.org/10.3390/s18072020>

Sinchuk O.M., Mykhailenko O.Yu., Horshkov V.V., Polishchuk P.I.

**VARIABILITY OF FORMATS OF ENERGY-
EFFICIENT STREET LIGHTING SYSTEMS FOR
SETTLEMENTS**

MONOGRAPH

Subscribe to print 29/08/2024. Format 60×90/16.
Edition of 300 copies.
Printed by “iScience” Sp. z o. o.
Warsaw, Poland
08-444, str. Grzybowska, 87
info@sciencecentrum.pl, <https://sciencecentrum.pl>



ISBN 978-83-68188-09-7



9 788368 188097